

# BARNES®

## Professional Plumbing

### INSTALLATION MANUAL Submersible Grinder Pump

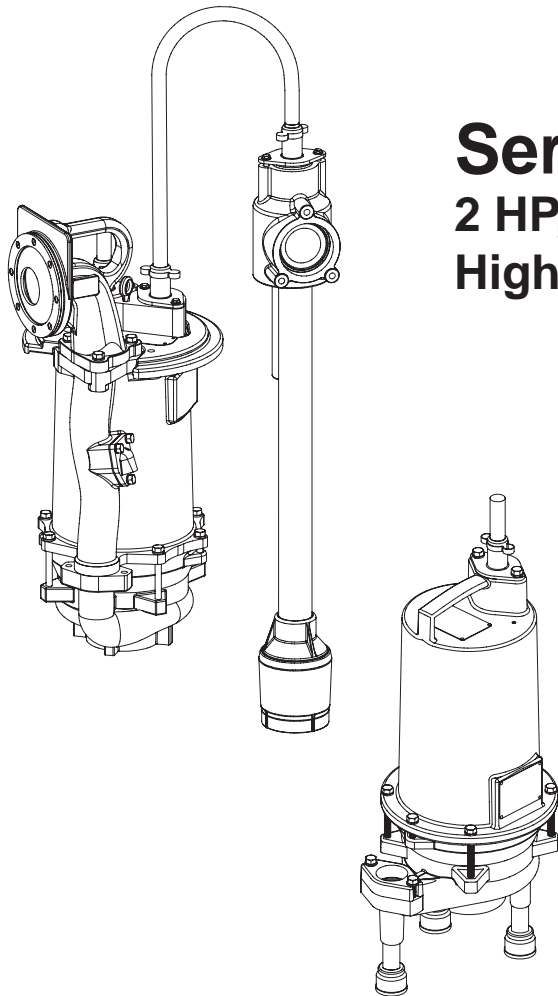

## Series: PGPP & PGPH

2 HP, 3450 RPM, 60 Hz.  
High-Flow and High-Head

**IMPORTANT!**

*Read all instructions in this manual before operating pump.  
As a result of Crane Pumps & Systems, Inc., constant product improvement program,  
product changes may occur. As such Crane Pumps & Systems reserves the right to  
change product without prior written notification.*

**CRANE**®

A Crane Co. Company

## PUMPS & SYSTEMS

420 Third Street  
Piqua, Ohio 45356  
Phone: (937) 778-8947  
Fax: (937) 773-7157  
[www.cranepumps.com](http://www.cranepumps.com)

83 West Drive, Bramton  
Ontario, Canada L6T 2J6  
Phone: (905) 457-6223  
Fax: (905) 457-2650



Form No. 131469-Rev. B

# SAFETY FIRST!

Please Read This Before Installing Or Operating Pump. This information is provided for **SAFETY and to PREVENT EQUIPMENT PROBLEMS**. To help recognize this information, observe the following symbols:



**IMPORTANT!** Warns about hazards that can result in personal injury or indicates factors concerned with assembly, installation, operation, or maintenance which could result in damage to the machine or equipment if ignored.

**CAUTION !** Warns about hazards that can or will cause minor personal injury or property damage if ignored. Used with symbols below.

**WARNING !** Warns about hazards that can or will cause serious personal injury, death, or major property damage if ignored. Used with symbols below.



Hazardous fluids can cause fire or explosions, burns or death could result.



Extremely hot - Severe burns can occur on contact.



Biohazard can cause serious personal injury.



Hazardous fluids can Hazardous pressure, eruptions or explosions could cause personal injury or property damage.



Rotating machinery Amputation or severe laceration can result.



Hazardous voltage can shock, burn or cause death.

Only qualified personnel should install, operate and repair pump. Any wiring of pumps should be performed by a qualified electrician.



**WARNING !** - To reduce risk of electrical shock, pumps and control panels must be properly grounded in accordance with the National Electric Code (NEC) or the Canadian Electrical Code (CEC) and all applicable state, province, local codes and ordinances.

**WARNING!** - To reduce risk of electrical shock, always disconnect the pump from the power source before handling or servicing. Lock out power and tag.

Prevent large articles of clothing, large amounts of chemicals, other materials or substances such as are uncommon in domestic sewage from entering the system.

During power black-outs, minimize water consumption at the home(s) to prevent sewage from backing up into the house.

Always keep the shut-off valve completely open when system is in operation (unless advised otherwise by the proper authorities). Before removing the pump from the basin, be sure to close the shut-off valve. (This prevents backflow from the pressure sewer.)

Keep the control panel locked or confined to prevent unauthorized access to it.

If the pump is idle for long periods of time, it is advisable to start the pump occasionally by adding water to the basin.



**CAUTION!** Pumps build up heat and pressure during operation-allow time for pumps to cool before handling or servicing.



**WARNING!** - **DO NOT** pump hazardous materials (flammable, caustic, etc.) unless the pump is specifically designed and designated to handle them.

Do not block or restrict discharge hose, as discharge hose may whip under pressure.



**WARNING!** - **DO NOT** wear loose clothing that may become entangled in the impeller or other moving parts.

**WARNING!** - Keep clear of suction and discharge openings. **DO NOT** insert fingers in pump with power connected.

Make sure lifting handles are securely fastened each time before lifting. Do not operate pump without safety devices in place. Always replace safety devices that have been removed during service or repair.

Do not exceed manufacturers recommendation for maximum performance, as this could cause the motor to overheat.

Secure the pump in its operating position so it can not tip over, fall or slide.

Cable should be protected at all times to avoid punctures, cut, bruises and abrasions - inspect frequently.



Never handle connected power cords with wet hands.

To reduce risk of electrical shock, all wiring and junction connections should be made per the NEC or CEC and applicable state or province and local codes. Requirements may vary depending on usage and location.



Submersible Pumps are not approved for use in swimming pools, recreational water installations, decorative fountains or any installation where human contact with the pumped fluid is common.

Do not remove cord and strain relief. Do not connect conduit to pump.



Products Returned Must Be Cleaned, Sanitized, Or Decontaminated As Necessary Prior To Shipment, To Insure That Employees Will Not Be Exposed To Health Hazards In Handling Said Material. All Applicable Laws And Regulations Shall Apply.

Bronze/brass and bronze/brass fitted pumps may contain lead levels higher than considered safe for potable water systems. Lead is known to cause cancer and birth defects or other reproductive harm. Various government agencies have determined that leaded copper alloys should not be used in potable water applications. For non-leaded copper alloy materials of construction, please contact factory.



**IMPORTANT!** - Crane Pumps & Systems, Inc. is not responsible for losses, injury, or death resulting from a failure to observe these safety precautions, misuse or abuse of pumps or equipment.

Other brand and product names are trademarks or registered trademarks of their respective holders.

© Barnes is a registered trademark of Crane Pumps & Systems, Inc.  
2002, 2003, 4/04, 5/04, 4/05, 12/05, 1/06, 9/06, 11/06, 2/07

Alteration Rights Reserved

# BARNES®

## *Professional Plumbing*

### USER GUIDE

Congratulations on your purchase of a Barnes grinder pump system. With proper care and by following a few simple guidelines your grinder pump will give you many years of dependable service.

### Use and Care

The grinder pump station is designed to handle routine, domestic sewage. Solid waste materials should be thrown in the trash. While your station is capable of accepting and pumping a wide range of materials, regulatory agencies advise that the following items should not be introduced into any sewer either directly or through a kitchen waste disposal:

- Glass
- Metal
- Diapers
- Socks, rags or cloth
- Plastic objects (e.g., toys, utensils, etc.)
- Sanitary napkins or tampons

In addition you must **NEVER** introduce into any sewer:

- Explosives
- Flammable Material
- Lubricating Oil and/or Grease
- Strong Chemicals
- Gasoline

### General Information

Your home wastewater disposal service is part of a low pressure sewer system. The key element in this system is the Barnes grinder pump station. The basin collects all wastewater from the house. The solids in the sewage are then ground to a small size suitable for pumping in the slurry.

The grinder pump generates sufficient pressure to pump this slurry from your home to the wastewater plant.

### Power Failure

Your grinder pump cannot dispose of wastewater or provide an alarm signal without electrical power. If electrical power service is interrupted, keep water usage to a minimum.

### Warranty

Your grinder pump is furnished with a warranty against defects in material or workmanship. A properly completed

Start-Up/Warranty Registration form must be on file at the Barnes factory in order to activate your warranty. In addition your pump must be installed in accordance with the installation instructions.

If you have a claim under the provisions of the warranty, contact your local Barnes Distributor.

When contacting your representative for service, please include your station serial number, pump model number, and pump serial number.

For future reference, record the following information:

Station Serial No: \_\_\_\_\_

Pump Model No: \_\_\_\_\_

Pump Serial No: \_\_\_\_\_

Local Distributor: \_\_\_\_\_

Distributor Telephone: \_\_\_\_\_

**BARNES**



# PUMP SPECIFICATIONS:

**DISCHARGE** ..... 1 1/4" NPT, Vertical, Bolt-on 1 1/4" BAF (CE Only) Flange

**LIQUID TEMPERATURE** .... 160°F (71°C) Intermittent

**MOTOR HOUSING** ..... Cast Iron ASTM A-48, Class 30

**VOLUTE**..... Cast Iron ASTM A-48, Class 30

**SEAL PLATE** ..... Cast Iron ASTM A-48, Class 30

**IMPELLER:**  
*Design* ..... 12 vane, vortex, with pump out vanes on back side. Dynamically balanced, ISO G6.3  
*Material* ..... Cast Iron

**SHREDDING RING** ..... Hardened 440C Stainless Steel Rockwell® C-55

**CUTTER** ..... Hardened 440C Stainless Steel Rockwell® C-55

**SHAFT**..... 416 Stainless Steel

**SQUARE RINGS**..... Buna-N

**HARDWARE** ..... 300 Series Stainless Steel

**PAINT** ..... Air dry enamel, top coat

**SEAL** *Design*..... Single Mechanical, oil filled reservoir  
*Material*..... Rotating Faces - Silicon-Carbide  
 Stationary Faces - Silicon-Carbide  
 Elastomer - Buna-N  
 Hardware - 300 series stainless steel

**CORD ENTRY** ..... 30 Ft. (9.1m); 15 Ft. (4.5m) Cord on, Compact series (CC, CE, CT), Custom Molded Quick Connected for sealing and strain relief.

**CORD** ..... CSA/UL Approved 12/3 & 12/5 Type SOW

**SPEED** ..... 3450 RPM, 60Hz (nominal)

**UPPER BEARING:**  
*Design*..... Single Row, Ball, Oil Lubricated  
*Load*..... Radial

**LOWER BEARING:**  
*Design*..... Single Row, Ball, Oil Lubricated  
*Load*..... Radial & Thrust

**MOTOR:** *Design*..... NEMA L, Single phase, includes overload protection in the motor)  
 Oil Filled, Squirrel Cage Induction  
*Insulation* ..... Class F

**SINGLE PHASE**..... Capacitor start/capacitor run.

**LEVEL CONTROLS:** ..... CE  
*Series*..... **SOLD SEPARATELY.** Model ESPS-150™ or ESPS-150E™ Environmentally sealed pressure switch with CPVC housing, Buna diaphragm, Custom molded Quick connect for sealing and strain relief.

**OPTIONAL EQUIPMENT**.... Seal Material, Additional Cord, Impeller trims, Moveable Fitting

**ESPS Level Control Sold Separatly**

**PGPP/PGPH**

inches  
(mm)

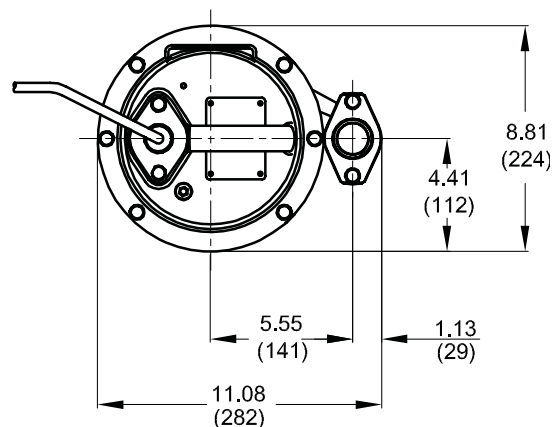
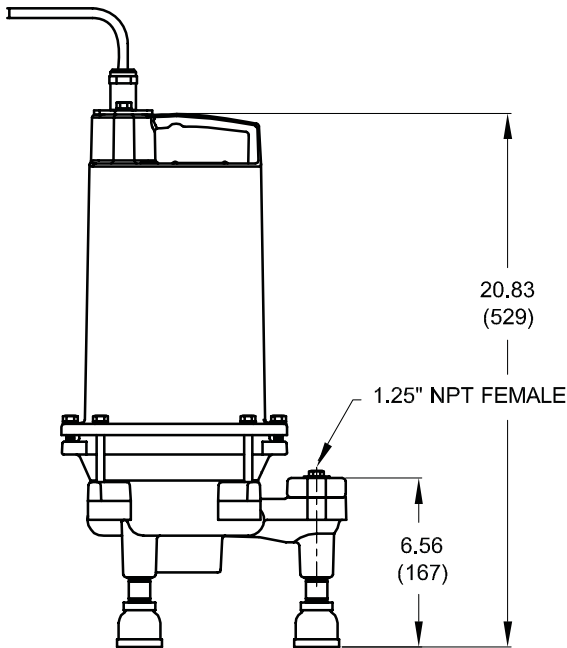

PGPH-CE - For EcoTRAN™

inches  
(mm)

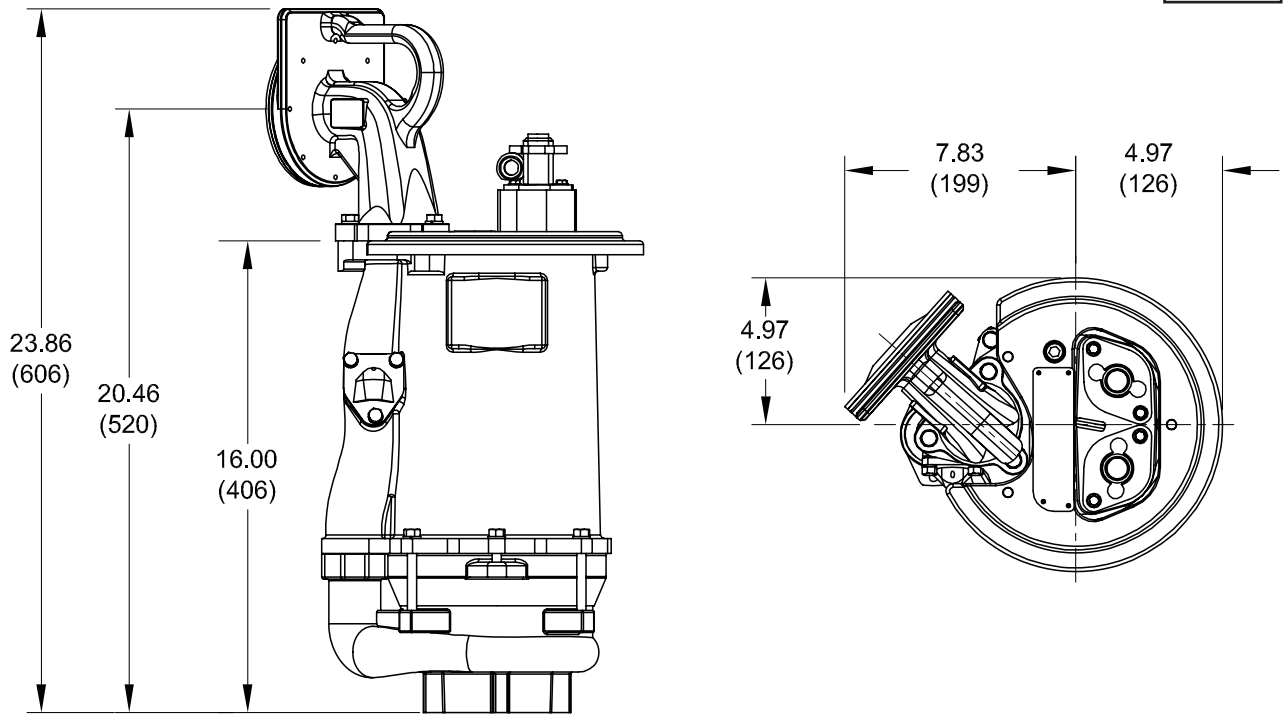

MODEL NO	HP	VOLT	PH/Hz	RPM (Nom)	NEMA START CODE	FULL LOAD AMPS	LOCKED ROTOR AMPS	CORD SIZE	CODE TYPE	CORD O.D. ± .02 (.5) in (mm)	WINDING RESISTANCE MAIN -- START
PGPH2022L	2	240	1 / 60	3450	H	15.0	53.8	12/3	SOW	.61 (15.5)	1.5 -- 5.1
PGPH2022CE	2	240	1 / 60	3450	H	15.0	53.8	12/3	SOW	.61 (15.5)	1.5 -- 5.1
PGPP2022L	2	240	1 / 60	3450	H	15.0	53.8	12/3	SOW	.61 (15.5)	1.5 -- 5.1

Winding Resistance ± 5%, measured from terminal block. Pump rated for operation at ± 10% voltage at motor.

Recommended Breaker & Heater Sizes				
Pump Model	HP	Phase	Volts	Breaker Size
All PGP Series Pumps	2	1	240	25 AMP

The nameplate is located on top of the pump. This contains the pumps part number, horsepower voltage, phase, and serial number, as well as other information. The start-up form located in the back of this manual contains a place to record this data. The information should be recorded now so the pump does not have to be pulled again later. The start-up form can be left in the control panel until station start-up is completed later.

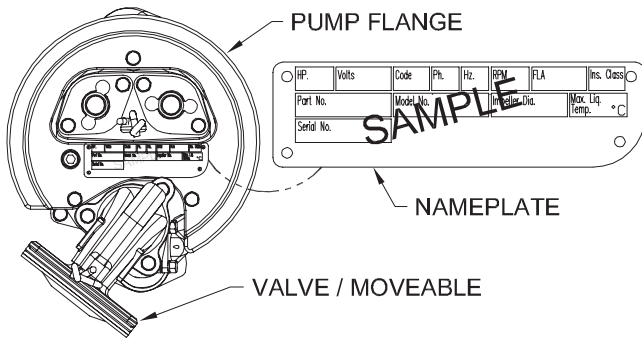

**PGPH-CE**

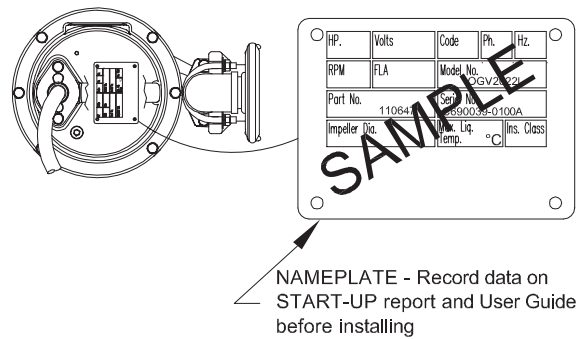

**PGPP & PGPH**

Tie the bowline knot where shown per the directions provided (Steps 1 through 5). On the CC and CE series, tie one bowline knot on the handle of the moveable fitting and one bowline knot in the eyebolt on the pump (See Fig 1). On the CT (Not Shown) series tie bowline knot on the eyebolt. On the L and AUE series tie bowline knot on the lifting handle. (See Fig 2).

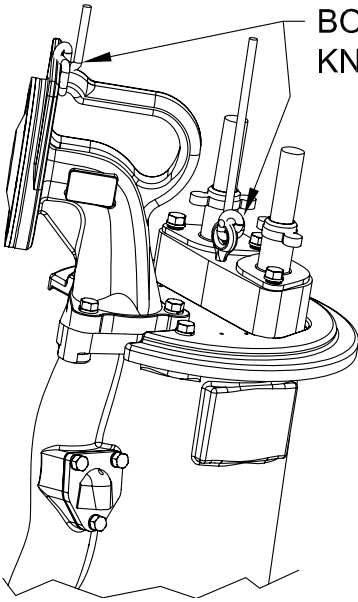

**BOWLINE KNOTS**

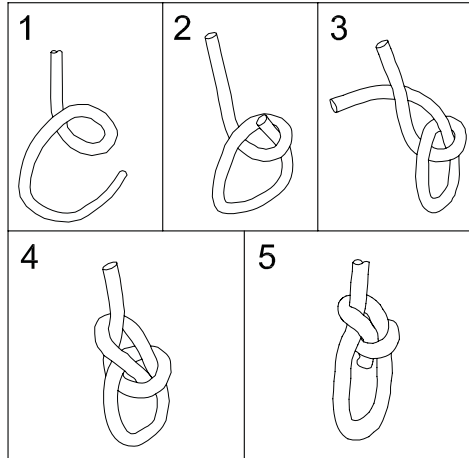

**FIGURE 1**

**LIFTING DEVICE !**  
Attach lifting device.  
**CAUTION! NEVER LOWER OR RAISE PUMP BY CORD.**

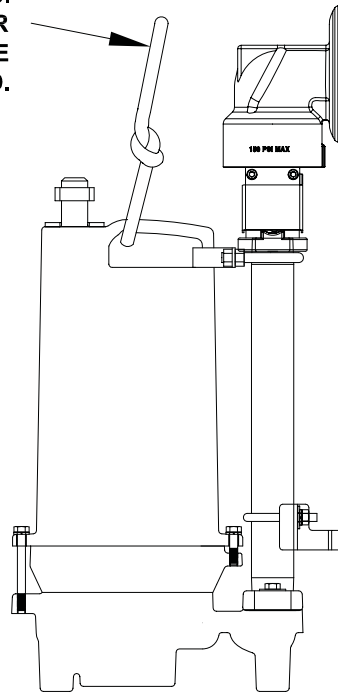

**FIGURE 2**

#### RECEIVING/UNPACKING:

Upon receiving the pump, it should be inspected for damage or shortages. If damage has occurred, file a claim immediately with the company that delivered the pump. Unpack pump and record pump serial and model number before installing. If the manual is removed from the packaging, do not lose or misplace.

#### STORAGE:

**Short Term-** For best results, pumps can be retained in storage, as factory assembled, in a dry atmosphere with constant temperatures for up to six (6) months.

**Long Term-** Any length of time exceeding six (6) months, but not more than twenty-four (24) months. The units should be stored in a temperature controlled area, a roofed over walled enclosure that provides protection from the elements (rain, snow, wind-blown dust, etc.), and whose temperature can be maintained between +40 deg. F and +120 deg. F. If extended high humidity is expected to be a problem, all exposed parts should be inspected before storage and all surfaces that have the paint scratched, damaged, or worn should be recoated with a air dry enamel paint. All surfaces should then be sprayed with a rust-inhibiting oil.

Pump should be stored in its original shipping container. On initial start up, rotate shaft by hand to assure seal and motor rotate freely. If it is required that the pump be installed and tested before the long term storage begins, such installation will be allowed provided:

- 1.) The pump is not installed under water for more than one (1) month.
- 2.) Immediately upon satisfactory completion of the test, the pump is removed, thoroughly dried, repacked in the original shipping container, and placed in a temperature controlled storage area.
- 3.) Before placing pump into service, pump should be brought to operational temperature range. Excessive or direct heating or cooling should **NOT** be used.

**OPERATION TEMPERATURE RANGE:** +35°F (2°C) to 104°F (40°C).

#### SERVICE CENTERS:

For the location of the nearest Barnes Service Center, check your Barnes representative or Crane Pumps & Systems, Inc., Service Department in Piqua, Ohio, telephone (937) 778-8947 or in Brampton, Ontario, Canada (905) 457-6223.

#### INSTALLATION:

**Location** - The pump is designed with pipe legs to keep a minimum of 3 inch clearance. **THIS PUMP MUST BE INSTALLED WITH A MINIMUM OF 3 INCHES CLEARANCE UNDER THE PUMP FOR THE ENTRANCE OF SEWAGE SOLIDS.**

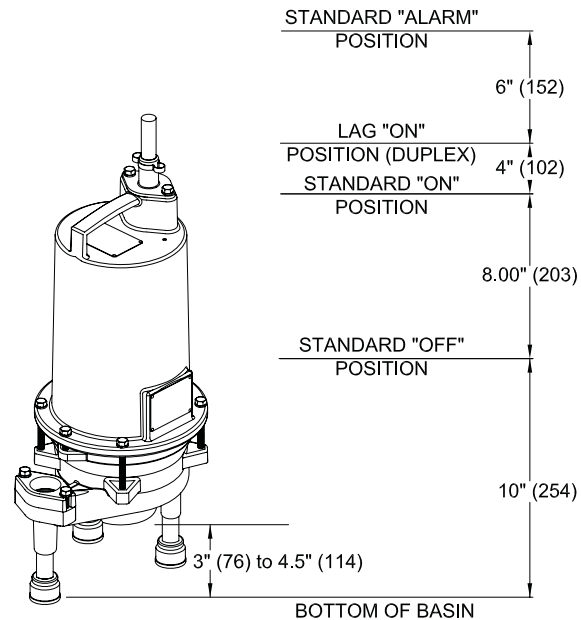

**FIGURE 3 - L Series (For Automatic see Level Control manual)**

**Discharge** - Assemble discharge piping or hose assembly (whichever is required by your application), to the pump. Discharge piping should be as short as possible. Both a check valve and a shut-off valve are required for each pump being used. The check valve is used to prevent backflow into the sump. Excessive backflow can cause flooding and/or damage to the pump. The shut-off valve is used to stop system flow during pump or check valve servicing. If pump is installed with a discharge hose rather than a moveable fitting assembly, make sure the discharge pipe has a 1/8" dia. hole approx. 5" from end nearest volute and oriented towards the pump body.

#### ELECTRICAL CONNECTIONS:

**Pump Cords** - The quick connect cord assembly mounted to the pump must **NOT** be modified in any way except for shortening to a specific application. Any supply cables connections between the pump and the control panel must be made in accordance with the National Electric Code or the Canadian Electric Code and all applicable state, province and local electric codes. It is recommended that a junction box, be mounted outside the sump or be of at least Nema 4 (EEMAC-4) construction if located within the wet well.

**DO NOT USE THE POWER OR CONTROL CABLES TO LIFT PUMP!**

**Overload Protection** - The type of in-winding overload protector used is referred to as an inherent overheating protector and operates on the combined effect of temperature and current. This means that the overload protector will trip out and shut the pump off if the windings become too hot, or the load current passing through them becomes too high. It will then automatically reset and start the pump up after the motor cools to a safe temperature. In the event of an overload, the source of this condition should be determined and rectified immediately. **DO NOT LET THE PUMP CYCLE OR RUN IF AN OVERLOAD CONDITION OCCURS !**

**Wire Size** - If additional cord is required consult a qualified



electrician for proper wire size.

**CORD CONNECTIONS:**

**Power/Control Cord-** Insert female end of cord plug into housing bore aligning alignment mark with hole in terminal block see Figures 4 and 5. Tighten bolts on compression flange until flush with motor housing.

Pump Power - Large Pin

Level Control - Small Pin

Level control cord has molded fitting at both ends of the cord. Install one end to the Pump and the other end to the Level Control.

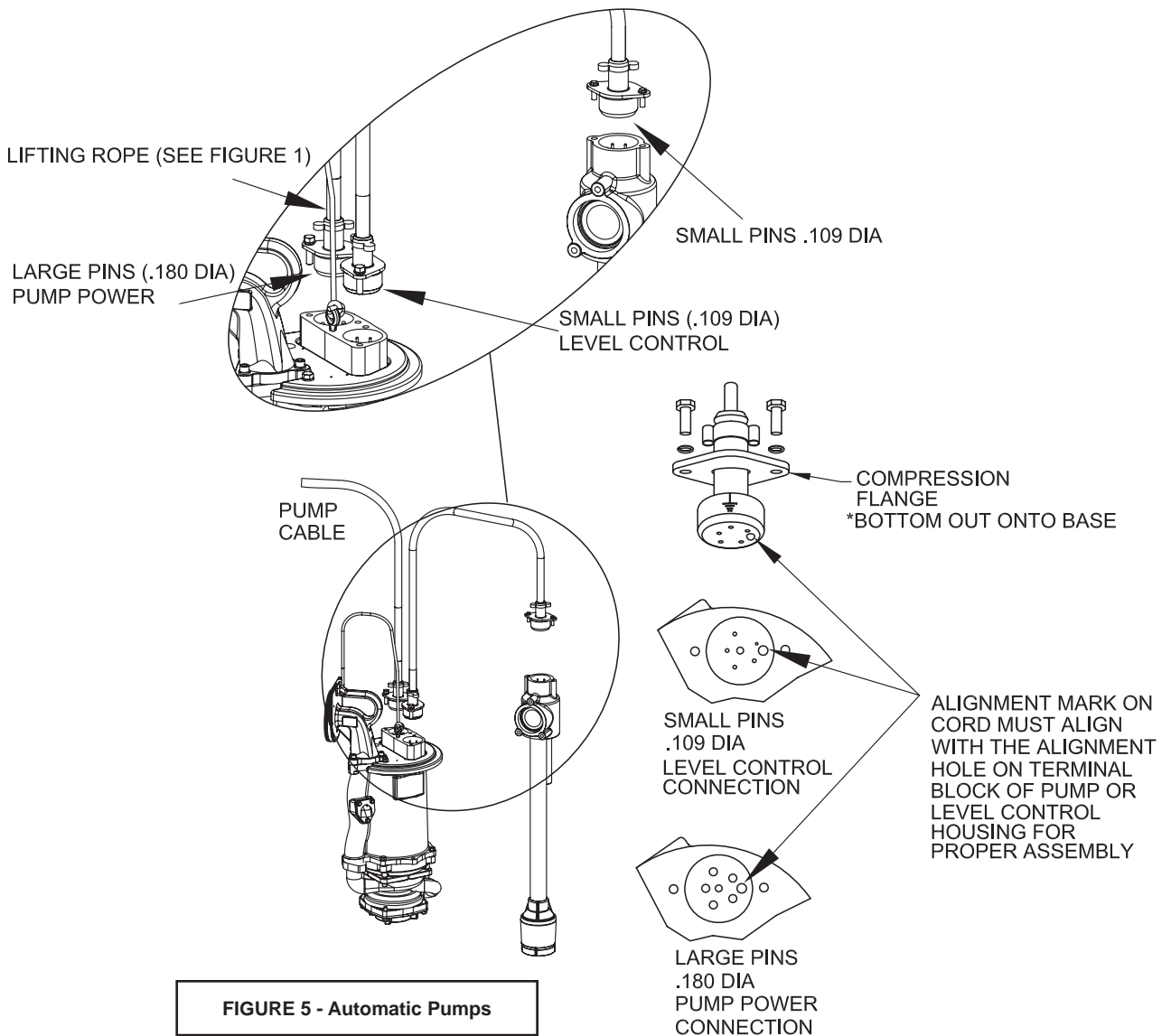
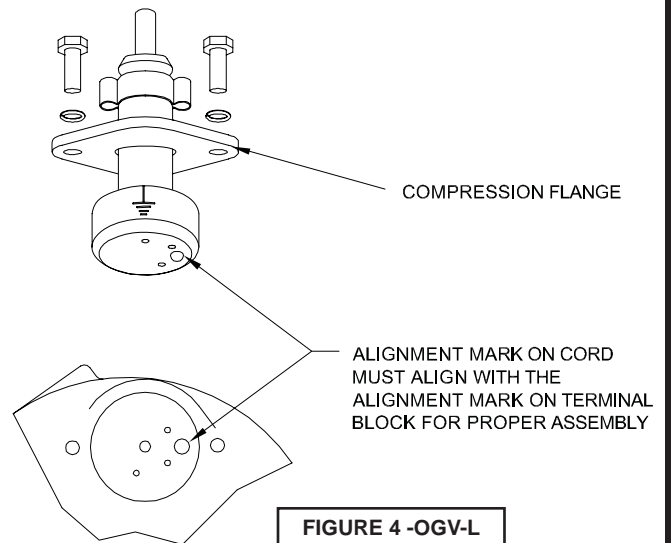

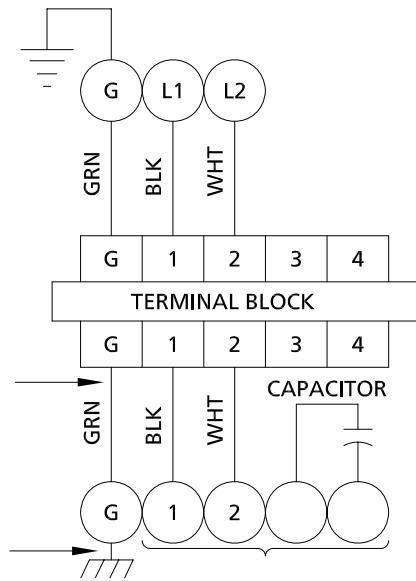

**FIGURE 6**

Single phase 240 Volt AC, 60Hz  
"L" Series, 12/3 SOW

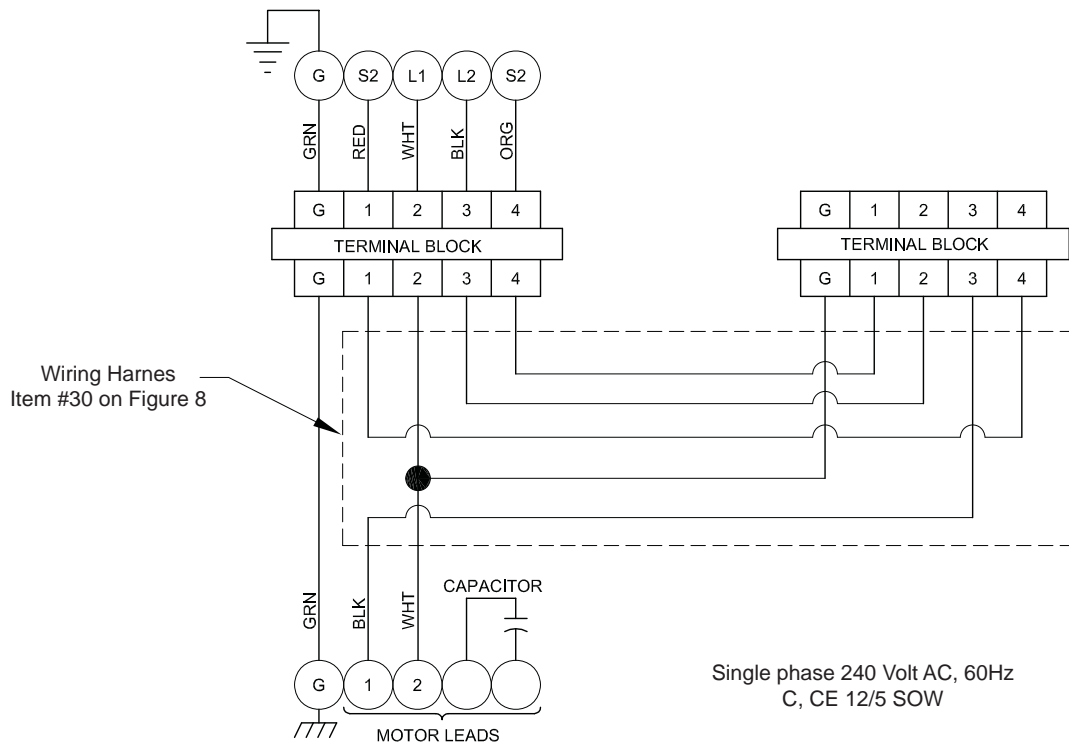

**FIGURE 7**

Single phase 240 Volt AC, 60Hz  
C, CE 12/5 SOW

## TROUBLE SHOOTING

CAUTION ! Always disconnect the pump from the electrical power source before handling.  
 If the system fails to operate properly, carefully read instructions and perform maintenance recommendations.  
 If operating problems persist, the following chart may be of assistance in identifying and correcting them:  
 MATCH "CAUSE" NUMBER WITH CORRELATING "CORRECTION" NUMBER.

NOTE: Not all problems and corrections will apply to each pump model.

PROBLEM	CAUSE	CORRECTION
Pump will not run	<ol style="list-style-type: none"> <li>1. Poor electrical connection, blown fuse, tripped breaker or other interruption of power, improper power supply.</li> <li>2. Motor or switch inoperative (to isolate cause, go to manual operation of pump).</li> <li>2a. Float movement restricted.</li> <li>2b. Switch will not activate pump or is defective.</li> <li>3a. Insufficient liquid level.</li> <li>3b. Switch is unable to activate</li> </ol>	<ol style="list-style-type: none"> <li>1. Check all electrical connections for security. Have electrician measure current in motor leads, if current is within <math>\pm 20\%</math> of locked rotor Amps, impeller is probably locked. If current is 0, overload may be tripped. Remove power, allow pump to cool, then recheck current.</li> <li>2a. Reposition pump or clean basin as required to provide adequate clearance for float.</li> </ol>
Pump will not turn off	<ol style="list-style-type: none"> <li>2a. Float movement restricted.</li> <li>2b. Switch will not activate pump or is defective.</li> <li>4. Excessive inflow or pump not properly sized for application.</li> <li>9. Pump may be airlocked.</li> <li>14. H-O-A switch on panel is in "HAND" position</li> </ol>	<ol style="list-style-type: none"> <li>2b. Disconnect level control. Set ohmmeter for a low range, such as 100 ohms full scale and connect to level control leads. Actuate level control manually and check to see that ohmmeter shows zero ohms for closed switch and full scale for open switch. (Float Switch).</li> <li>3a. Make sure liquid level is at least equal to suggested turn-on point.</li> <li>3b. Rotate ESPS level control in horizontal position.</li> </ol>
Pump hums but does not run	<ol style="list-style-type: none"> <li>1. Incorrect voltage</li> <li>8. Cutter jammed or loose on shaft, worn or damaged, inlet plugged.</li> </ol>	<ol style="list-style-type: none"> <li>4. Recheck all sizing calculations to determine proper pump size.</li> </ol>
Pump delivers insufficient capacity	<ol style="list-style-type: none"> <li>1. Incorrect voltage.</li> <li>4. Excessive inflow or pump not properly sized for application.</li> <li>5. Discharge restricted.</li> <li>6. Check valve stuck closed or installed backwards.</li> <li>7. Shut-off valve closed.</li> <li>8. Cutter jammed or loose on shaft, worn or damaged, inlet plugged.</li> <li>9. Pump may be airlocked.</li> <li>10. Pump stator damaged/torn.</li> </ol>	<ol style="list-style-type: none"> <li>5. Check discharge line for restrictions, including ice if line passes through or into cold areas.</li> <li>6. Remove and examine check valve for proper installation and freedom of operation.</li> <li>7. Open valve.</li> <li>8. Check cutter for freedom of operation, security and condition. Clean cutter and inlet of any obstruction.</li> <li>9. Loosen union slightly to allow trapped air to escape. Verify that turn-off level of switch is set so that the suction is always flooded. Clean vent hole.</li> </ol>
Pump cycles too frequently or runs periodically when fixtures are not in use	<ol style="list-style-type: none"> <li>6. Check valve stuck closed or installed backwards.</li> <li>11. Fixtures are leaking.</li> <li>15. Ground water entering basin.</li> </ol>	<ol style="list-style-type: none"> <li>10. Remove &amp; examine for damage. Replace pump stator if required.</li> <li>11. Repair fixtures as required to eliminate leakage.</li> </ol>
Pump shuts off and turns on independent of switch, (trips thermal overload protector). <b>CAUTION!</b> Pump may start unexpectedly. Disconnect power supply.	<ol style="list-style-type: none"> <li>1. Incorrect voltage.</li> <li>4. Excessive inflow or pump not properly sized for application.</li> <li>8. Cutter jammed, loose on shaft, worn or damaged, inlet plugged.</li> <li>12. Excessive water temperature.</li> </ol>	<ol style="list-style-type: none"> <li>12. Check pump temperature limits &amp; fluid temperature.</li> <li>13. Replace portion of discharge pipe with flexible connector.</li> <li>14. Turn to automatic position.</li> </ol>
Pump operates noisily or vibrates excessively	<ol style="list-style-type: none"> <li>4. Operating at too high a pressure.</li> <li>5. Discharge restricted.</li> <li>8. Cutter broken.</li> <li>13. Piping attachments to building structure too rigid or too loose.</li> </ol>	<ol style="list-style-type: none"> <li>15. Check for leaks around basin inlet and outlets.</li> </ol>

MANUAL MODELS

AUTOMATIC MODELS  
"CE"

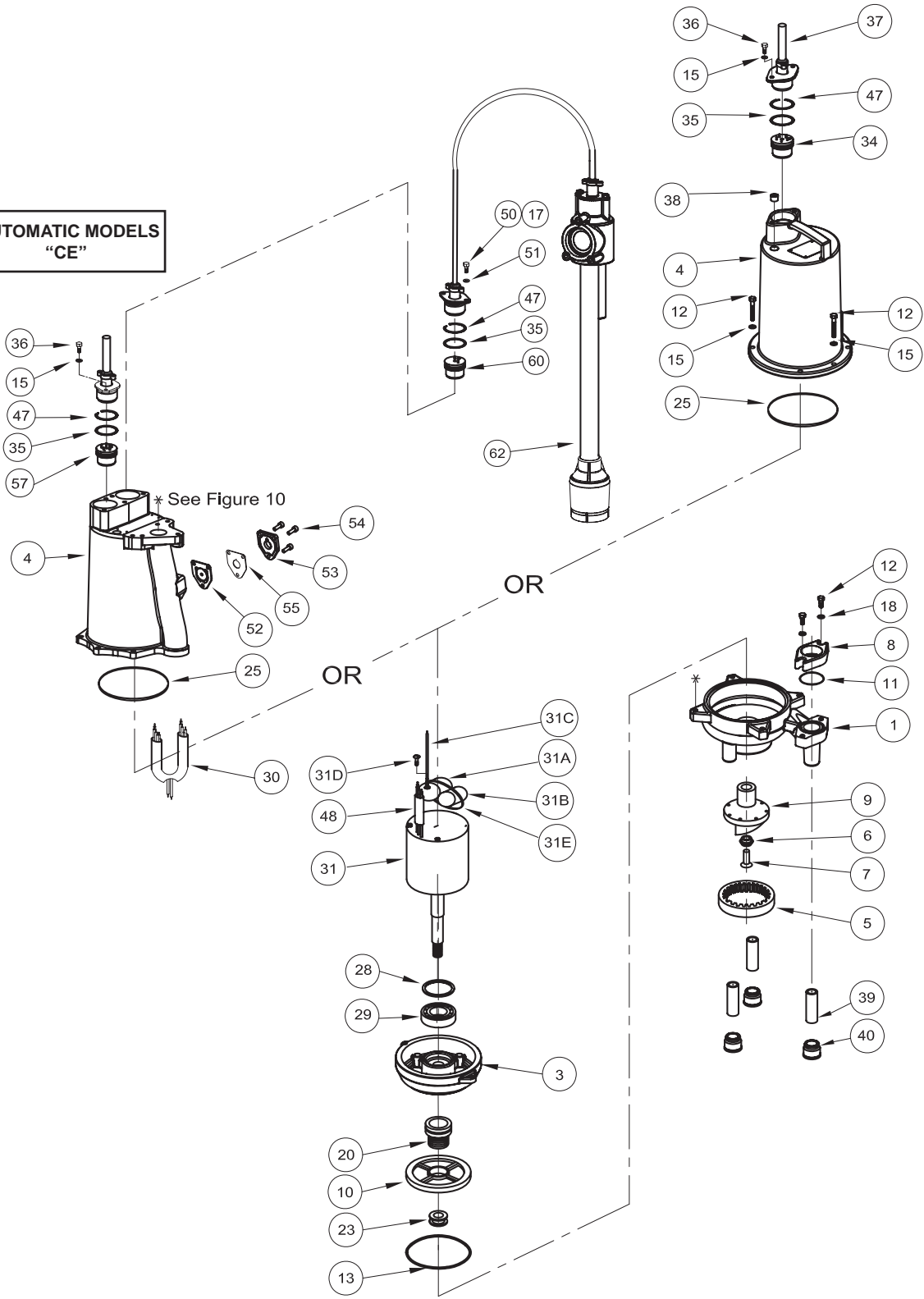

FIGURE 8

**PARTS KITS**

Seal Repair Kit .....P/N: 108303  
 Overhaul Kit ..... P/N: 127238  
 Cutter Kit - PGPP .....P/N: 108330  
 Cutter Kit - PGPH .....P/N: 108330A

Item #'s 6,7,12,13,15,20,25,26,35,36,47  
 108303 & Item #'s 9, 18, 28, 29, 31A, 31B, 31C, 31D, 38  
 Item #'s 5, 6, 7, 9, 15, 23, 26  
 Item #'s 5, 6, 7, 9, 15, 23, 26

**PARTS LIST**

ITEM	QTY	PART NO.	DESCRIPTION
1	1	108344 118246	Volute Volute (CE)
2	1	110331	Handle (AU model)
3	1	108343	Seal Plate
4	1	108342 110328 118256	Motor Housing (STD) Motor Housing (AU model) Motor Housing (CE, CC, CT)
5	1	082085A 082085B	Shredding Ring (OGVF) Shredding Ring (OGVH)
6	1	067556	Washer
7	1	070704	Skhd Screw, 1/4-20 x .75" SS
8	1	108369 †	Discharge Flange 1-1/4" NPT
9	1	082088	Radial Cutter
10	1	109026B 109026BTD	Impeller, 5.62" Dia. (OGVH) Impeller, 5.13" Dia. (OGVF)
11	1	625-01558	O-Ring (-223)
12	4	1-131-1 †	Screw, 5/16-18 x 1.25" SS
13	1	067564	Square Ring
15	14	026322	Lockwasher, 5/16" SS
16	A/R	-----	LOCTITE™ RC609
17	A/R	-----	LOCTITE 242
18	2	062941 †	5/16" Flatwasher
20	1	110395SD	Seal, outer Silicon-Carbide (STD)
22	A/R	-----	Permatex Sealent 2C
23	1	016079	Shim set
24	3 Qts.	029034	Cooling Oil - Mtr. Housing
25	1	095368	Square Ring
26	4	1-300-1	Screw, 5/16-18 x 1.25", SS
28	1	061143	Retaining Ring
29	1	Q10-36-E4	Ball Bearing, Lower
30	1	113287	Wiring Harnes (Automatic)
31	1	108368A	Motor, 2HP, 240 Volt, 1 Phase w/capacitors & Ground wire (Supplied with Upper Bearing)
31A	1	112470	Capacitor, Run
31B	1	099198	Capacitor, Start
31C	1	105111B	Ground wire
31D	1	016660	Screw, Self-Tap #8-32 x .31"
31E	6	039462	Cable tie strap
34	1	103760	Terminal Block, Power, Manual
35	1 or 2	2-31051-224	O-Ring
36	2	1-156-1	Screw, 5/16-18 x 1.00" SS

ITEM	QTY	PART NO.	DESCRIPTION
37	1	109498XC 109498	12/3 Cord Set, 30 Ft 15Ft Cord on CC, CE,CT
38	1	014270	Pipe Plug, C'sunk, 3/8" NPT
39	3	110660	1/2" x 2-1/2" Nipple
40	3	111328	1/2" x 1" Reducer
47	1 or 2	105197	Retaining Ring
48	1 or 2	625-02117	Sleeving
<b>* Models with ESPS Level Control</b>			
50	4	1-156-1	Screw, 5/16-18 x .1" SS
51	4	026322	Lockwasher, 5/16" SS
52	1	119104B	Gasket
53	1	112422	Anti-Siphon Cover
54	3	03121-B	HxHd Screw 1/4-20 x .75" SS
55	1	105377B	Anti-Siphon Cover Plate
56	1	113274XC 113274 EcoTRAN	12/5 Cord Set 30Ft.- (AU) 15 FT on CC, CE, CT Cord Set (CE - See manual 119061)
57	1	113271	Terminal Block, Power
60	1	113272	Terminal Block, Level Control
62	1	121676-M 119068	ESPS-150 Level Control (AUE) CE Only

Contact your local Distributor or the Factory for other impeller sizes, seal materials, cord lengths and other optional equipment.

(\*) AUE - ESPS Level Control

(\*\*) Items 31A thru 31E are included with item 31 motor.

(†) L Series Only. NOT USED ON CC, CE, CT.

## DISCHARGE ASSEMBLIES for CC, CE & CT Grinder Pumps

ITEM	QTY.	PART No.	DESCRIPTION
1	1	121225	O-ring, 4mm
2	1	118251	Valve Seat Flapper, Brz
3	1	118252	Gasket
4	2	112725	Pin .125 x .75 SS
5	3	1-156-1	HXHD Screw 5/16-18 x 1.00" SS
6	3 or 6	026322	Lock Washer 5/16 SS
7B	1	118250	Valve Body (CE)
8	1	118253	Pump Support Plate
9	1	119854	Diaphragm
10	1	118248	Diaphragm Retaining Plate
11	8	118267	FHHS Screw #10-32 x .75" SS
12	3	2-23030-50	SkHd Screw 5/16-18 x 1.25" Lg

The Discharge Assembly will be factory assembled to pump.

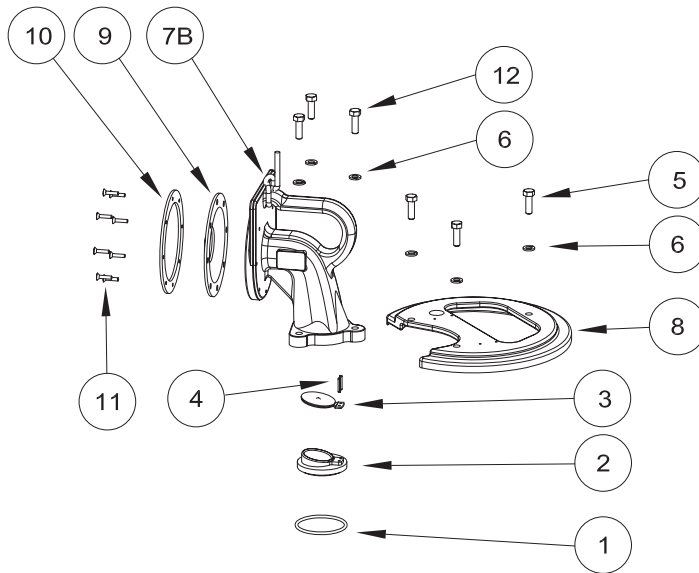

**OGV-CE**

**FIGURE 10**

BARNES®

BARNES®  
PRESSURE **PS** SYSTEMS



burks®

WEINMAN®

DEMING®

PROSSER®

## *Limited 24 Month Warranty*

Crane Pumps & Systems warrants that products of our manufacture will be free of defects in material and workmanship under normal use and service for twenty-four (24) months after manufacture date, when installed and maintained in accordance with our instructions. This warranty gives you specific legal rights, and there may also be other rights which vary from state to state. In the event the product is covered by the Federal Consumer Product Warranties Law (1) the duration of any implied warranties associated with the product by virtue of said law is limited to the same duration as stated herein, (2) this warranty is a LIMITED WARRANTY, and (3) no claims of any nature whatsoever shall be made against us, until the ultimate consumer, his successor, or assigns, notifies us in writing of the defect, and delivers the product and/or defective part(s) freight prepaid to our factory or nearest authorized service station. Some states do not allow limitations on how long an implied warranty lasts, so the above limitation may not apply. **THE SOLE AND EXCLUSIVE REMEDY FOR BREACH OF ANY AND ALL WARRANTIES WITH RESPECT TO ANY PRODUCT SHALL BE TO REPLACE OR REPAIR AT OUR ELECTION, F.O.B. POINT OF MANUFACTURE OR AUTHORIZED REPAIR STATION, SUCH PRODUCTS AND/OR PARTS AS PROVEN DEFECTIVE. THERE SHALL BE NO FURTHER LIABILITY, WHETHER BASED ON WARRANTY, NEGLIGENCE OR OTHERWISE.** Unless expressly stated otherwise, guarantees in the nature of performance specifications furnished in addition to the foregoing material and workmanship warranties on a product manufactured by us, if any, are subject to laboratory tests corrected for field performance. Any additional guarantees, in the nature of performance specifications must be in writing and such writing must be signed by our authorized representative. Due to inaccuracies in field testing if a conflict arises between the results of field testing conducted by or for user, and laboratory tests corrected for field performance, the latter shall control. **RECOMMENDATIONS FOR SPECIAL APPLICATIONS OR THOSE RESULTING FROM SYSTEMS ANALYSES AND EVALUATIONS WE CONDUCT WILL BE BASED ON OUR BEST AVAILABLE EXPERIENCE AND PUBLISHED INDUSTRY INFORMATION. SUCH RECOMMENDATIONS DO NOT CONSTITUTE A WARRANTY OF SATISFACTORY PERFORMANCE AND NO SUCH WARRANTY IS GIVEN.**

This warranty shall not apply when damage is caused by (a) improper installation, (b) improper voltage (c) lightning (d) excessive sand or other abrasive material (e) scale or corrosion build-up due to excessive chemical content. Any modification of the original equipment will also void the warranty. We will not be responsible for loss, damage or labor cost due to interruption of service caused by defective parts. Neither will we accept charges incurred by others without our prior written approval.

This warranty is void if our inspection reveals the product was used in a manner inconsistent with normal industry practice and/or our specific recommendations. The purchaser is responsible for communication of all necessary information regarding the application and use of the product. **UNDER NO CIRCUMSTANCES WILL WE BE RESPONSIBLE FOR ANY OTHER DIRECT OR CONSEQUENTIAL DAMAGES, INCLUDING BUT NOT LIMITED TO TRAVEL EXPENSES, RENTED EQUIPMENT, OUTSIDE CONTRACTOR FEES, UNAUTHORIZED REPAIR SHOP EXPENSES, LOST PROFITS, LOST INCOME, LABOR CHARGES, DELAYS IN PRODUCTION, IDLE PRODUCTION, WHICH DAMAGES ARE CAUSED BY ANY DEFECTS IN MATERIAL AND/OR WORKMANSHIP AND/OR DAMAGE OR DELAYS IN SHIPMENT. THIS WARRANTY IS EXPRESSLY IN LIEU OF ANY OTHER EXPRESS OR IMPLIED WARRANTY, INCLUDING ANY WARRANTY OF MERCHANTABILITY OR FITNESS FOR A PARTICULAR PURPOSE.**

No rights extended under this warranty shall be assigned to any other person, whether by operation of law or otherwise, without our prior written approval.

**CRANE**<sup>®</sup>

PUMPS & SYSTEMS

A Crane Co. Company

420 Third Street  
Piqua, Ohio 45356  
Phone: (937) 778-8947  
Fax: (937) 773-7157  
www.cranepumps.com

83 West Drive, Brampton  
Ontario, Canada L6T 2J6  
Phone: (905) 457-6223  
Fax: (905) 457-2650

**IMPORTANT!  
WARRANTY REGISTRATION**

Your product is covered by the enclosed Warranty.  
To complete the Warranty Registration Form go to:

<http://www.cranepumps.com/ProductRegistration/>

If you have a claim under the provision of the warranty, contact your local  
Crane Pumps & Systems, Inc. Distributor.

**RETURNED GOODS**

**RETURN OF MERCHANDISE REQUIRES A "RETURNED GOODS AUTHORIZATION".  
CONTACT YOUR LOCAL CRANE PUMPS & SYSTEMS, INC. DISTRIBUTOR.**



**Products Returned Must Be Cleaned, Sanitized,  
Or Decontaminated As Necessary Prior To Shipment,  
To Insure That Employees Will Not Be Exposed To Health  
Hazards In Handling Said Material. All Applicable Laws  
And Regulations Shall Apply.**





**START-UP REPORT**

**General Information**

Pump Owner's Name: \_\_\_\_\_  
Address: \_\_\_\_\_  
Location of Installation: \_\_\_\_\_  
Contact Person: \_\_\_\_\_ Phone: \_\_\_\_\_  
Purchased From: \_\_\_\_\_

**Nameplate Data**

Pump Model #: \_\_\_\_\_ Serial #: \_\_\_\_\_  
Part #: \_\_\_\_\_ Impeller Diameter: \_\_\_\_\_  
Voltage: \_\_\_\_\_ Phase: \_\_\_\_\_ Ø Hertz: \_\_\_\_\_ Horsepower: \_\_\_\_\_  
Full Load Amps: \_\_\_\_\_ Service Factor Amps: \_\_\_\_\_  
Motor Manufacturer: \_\_\_\_\_

**Controls**

Control panel manufacturer: \_\_\_\_\_  
Model/Part number: \_\_\_\_\_  
Number of pumps operated by control panel: \_\_\_\_\_  
Short circuit protection? YES\_\_\_ NO\_\_\_ Type: \_\_\_\_\_  
Number and size of short circuit device(s): \_\_\_\_\_ Amp rating: \_\_\_\_\_  
Overload Type: \_\_\_\_\_ Size: \_\_\_\_\_ Amp rating: \_\_\_\_\_  
Do protection devices comply with pump and motor Amp rating? YES\_\_\_ NO\_\_\_  
Are all electrical and panel entry connections tight? YES\_\_\_ NO\_\_\_  
Is the interior of the panel dry? YES\_\_\_ NO\_\_\_  
Liquid level Control Brand and Model: \_\_\_\_\_

**Pre-Startup**

**All Pumps**

Type of equipment: NEW\_\_\_ REBUILT\_\_\_ USED\_\_\_  
Condition of equipment at Start-Up: DRY\_\_\_ WET\_\_\_ MUDDY\_\_\_  
Was Equipment Stored? YES\_\_\_ NO\_\_\_ Length of Storage: \_\_\_\_\_  
Liquid being pumped: \_\_\_\_\_ Liquid Temperature: \_\_\_\_\_  
Supply Voltage/Phase/Frequency matches nameplate? YES\_\_\_ NO\_\_\_  
Shaft turns freely? YES\_\_\_ NO\_\_\_  
Direction of rotation verified for 3Ø motors? YES\_\_\_ NO\_\_\_  
Debris in piping or wet well? YES\_\_\_ NO\_\_\_  
Debris removed in your presence? YES\_\_\_ NO\_\_\_  
Pump case/wet well filled with liquid before startup? YES\_\_\_ NO\_\_\_  
Is piping properly supported? YES\_\_\_ NO\_\_\_

**Non-Submersible Pumps**

Is base plate properly installed / grouted? YES\_\_\_ NO\_\_\_ N/A\_\_\_  
Coupling Alignment Verified per I&O Manual? YES\_\_\_ NO\_\_\_ N/A\_\_\_  
Grease Cup/Oil Reservoir Level checked? YES\_\_\_ NO\_\_\_ N/A\_\_\_

**Submersible Pumps**

Resistance of cable and pump motor (measured at pump control):

Red-Black: \_\_\_\_\_ Ohms(Ω) Red-White: \_\_\_\_\_ Ohms(Ω) White-Black: \_\_\_\_\_ Ohms(Ω)

Resistance of Ground Circuit between Control Panel and outside of pump: \_\_\_\_\_ Ohms(Ω)

MEG Ohms check of insulation:

Red to Ground: \_\_\_\_\_ White to Ground: \_\_\_\_\_ Black to Ground: \_\_\_\_\_

**Operational Checks**

Is there noise or vibration present? YES\_\_\_ NO\_\_\_ Source of noise/vibration: \_\_\_\_\_

Does check valve operate properly? YES\_\_\_ NO\_\_\_ N/A\_\_\_

Is system free of leaks? YES\_\_\_ NO\_\_\_ Leaks at: \_\_\_\_\_

Does system appear to operate at design flow rate? YES\_\_\_ NO\_\_\_

Nominal Voltage: \_\_\_\_\_ Phase: 1Ø 3Ø (select one)

Voltage Reading at panel connection, Pump OFF: L1, L2 \_\_\_\_\_ L2, L3 \_\_\_\_\_ L1, L3 \_\_\_\_\_

Voltage Reading at panel connection, Pump ON: L1, L2 \_\_\_\_\_ L2, L3 \_\_\_\_\_ L1, L3 \_\_\_\_\_

Amperage Draw, Pump ON: L1 \_\_\_\_\_ L2 \_\_\_\_\_ L3 \_\_\_\_\_

**Submersible Pumps**

Are BAF and guide rails level / plumb? YES\_\_\_ NO\_\_\_

Is pump seated on discharge properly? YES\_\_\_ NO\_\_\_

Are level controls installed away from turbulence? YES\_\_\_ NO\_\_\_

Is level control operating properly? YES\_\_\_ NO\_\_\_

Is pump fully submerged during operation? YES\_\_\_ NO\_\_\_

**Follow up/Corrective Action Required**

YES\_\_\_ NO\_\_\_

**Additional Comments:**

\_\_\_\_\_  
\_\_\_\_\_  
\_\_\_\_\_  
\_\_\_\_\_  
\_\_\_\_\_  
\_\_\_\_\_  
\_\_\_\_\_

Startup performed by: \_\_\_\_\_ Date: \_\_\_\_\_

**Present at Start-Up**

( ) Engineer: \_\_\_\_\_ ( ) Operator: \_\_\_\_\_

( ) Contactor: \_\_\_\_\_ ( ) Other: \_\_\_\_\_

**All parties should retain a copy of this report for future trouble shooting/reference**



**PUMPS & SYSTEMS**

A Crane Co. Company

420 Third Street  
Piqua, Ohio 45356  
Phone: (937) 778-8947  
Fax: (937) 773-7157  
www.cranepumps.com

83 West Drive, Brampton  
Ontario, Canada L6T 2J6  
Phone: (905) 457-6223  
Fax: (905) 457-2650