

Vertical In-Line Chemical & Process Pumps

STD. PUMP DESIGNATION	PUMP SIZE	SUCT.	DISCH.	MAX. IMP. DIA.	WT	A	B	C	T	E	X	VY	SD
---	VAA-E	1½	1	6	64	1⅞	8⅞	1¾	3⅞	4	6½	7½	14
3015 / 15	VAB-E	3	1½		80	1⅞	9¾	2	4⅞	4	6¼	8¾	15
3020 / 17	VA10-E	3	2	7¼	107	2⅞	11⅞	2	4⅞	4⅞	7¾	9¼	17
---	VA05-E	2	1	9½	115	2	12¾	2⅞	4⅞	4	8½	10½	19
3015 / 19	VA50-E	3	1½		126	2⅞	13¾	2⅞	5⅞	4¼	8½	10½	19
3020 / 20	VA60-E	3	2		132	2⅞	13¾	2⅞	5⅞	4¼	9½	10½	20
4030 / 22	VA70-E	4	3	12	168	2⅞	14¾	3	5⅞	5	11	11	22
3015 / 24	VA20-E	3	1½		161	2⅞	16¾	2¼	4⅞	4¼	12½	11½	24
3020 / 24	VA30-E	3	2		161	2⅞	16¾	2¼	4⅞	4¼	11½	12½	24
4030 / 25	VA40-E	4	3		223	2⅞	18¾	3¼	6⅞	5	12½	12½	25
6040 / 28	VA80-E	6	4	312	2⅞	19¾	3¼	7⅞	5⅞	13½	14½	28	

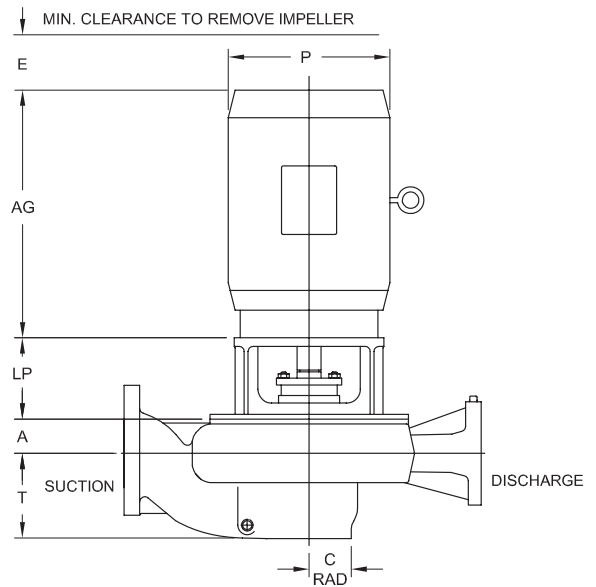
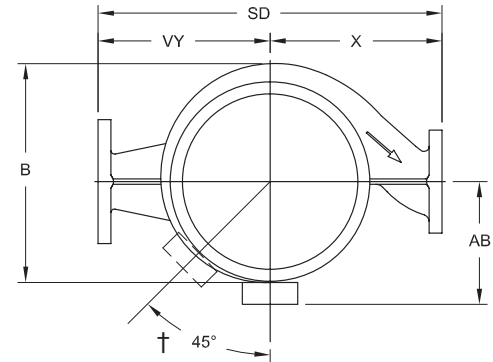

FLANGE DRILLING DATA Δ								
NOZZLE SIZE	150# FLANGE				300# FLANGE			
	NO.	SIZE	B.C.	DIA.	NO.	SIZE	B.C.	DIA.
1	4	⅝	3⅞	4¼	4	¾	3½	4⅞
1½	4	⅝	3⅞	5	4	⅞	4½	6⅞
2	4	¾	4¾	6	8	¾	5	6½
3	4	¾	6	7½	8	⅞	6⅞	8¼
4	8	¾	7½	9	8	⅞	7⅞	10
6	8	⅞	9½	11	12	⅞	10⅞	12½

(†) CAN BE ROTATED IN INCREMENTS OF 90°, 364-365TC FRAME ONLY.
 (Δ) FLANGE THICKNESS PER ANSI STANDARD B123.1-1971, FLAT FACE
 (*) COULD ALSO BE "TC" FRAMES

NOTE: PUMP DESIGNATION: DEFINES DESIGN, FLANGE SIZES AND "SD" DIMENSIONS

MOTOR DATA		FIGURE															
		3182						3185						3186			
FRAME		*143 JP	*145 JP	182 JP	184 JP	213 TC	215 TC	213 JP	215 JP	*254 JP	*256 JP	284 JP	286 JP	*324 JP	*326 JP	364 JP	365 JP
TOTALLY ENCLOSED EXPLOSION PROOF	HP. at 3600	1½	2	3	5	7½	10	7½	10	15	20	25	30	40	50	60	75
	HP. at 1800	1	2	3	5	7½	10	7½	10	15	20	25	30	40	50	60	75
	WEIGHT	40	45	95	110	140	175	145	180	245	305	375	465	575	635	815	940
	P	6½	6½	9⅞	9⅞	11¼	11¼	11¼	11¼	13¼	13¼	14¼	14¼	17	17	19⅞	19⅞
	AB	4⅞	4⅞	8⅞	8⅞	9⅞	9⅞	9⅞	9⅞	11⅞	11⅞	12¼	12¼	13¼	13¼	17⅞	17⅞
	AG	11½	12	12⅞	13⅞	15⅞	16⅞	15⅞	16⅞	19¼	21½	21⅞	22⅞	23⅞	25⅞	27	28
LP	5⅞	5⅞	5⅞	5⅞	5⅞	5⅞	5⅞	5⅞	5⅞	5⅞	5⅞	5⅞	5⅞	5⅞	5⅞	5⅞	
DRIP-PROOF	HP. at 3600	1½	3	5	7½	10	15	10	15	20	25	30	40	50	60	75	100
	HP. at 1800	1	2	3	5	7½	10	7½	10	15	20	25	30	40	50	60	75
	WEIGHT	40	45	75	90	120	145	125	150	220	260	320	375	455	500	705	770
	P	6½	6½	9⅞	9⅞	11	11	11	11	13⅞	13⅞	14¼	14¼	16¼	16¼	18⅞	18⅞
	AB	4⅞	4⅞	7⅞	7⅞	8⅞	8⅞	8⅞	8⅞	10⅞	10⅞	11¼	11¼	14⅞	14⅞	15⅞	15⅞
	AG	11⅞	11⅞	10⅞	11⅞	13⅞	15	13⅞	15	17¼	19	19	20½	21⅞	22⅞	23⅞	24⅞
LP	5⅞	5⅞	5⅞	5⅞	5⅞	5⅞	5⅞	5⅞	5⅞	5⅞	5⅞	5⅞	5⅞	5⅞	5⅞	5⅞	

Customer				Shop Order No.				Date:		By:	
Pump Data	Fig. No.	Size	Curve No.	GPM	Head	Sp. Gr.	Temp.	Rotation	Packing/Seal		
Motor Data	MFGR	Hp	RPM	Phase-Cycle Voltage		Frame	Enclosure	Insulation	Furnished by	Mounted by	