

# Size 10TB (Dual Vane)

7366\*-X70

# DEMING®

www.cranepumps.com

## Demersible Chopper Pumps

#5 Frame Driver

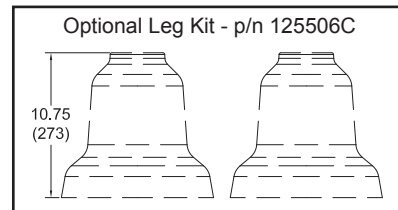
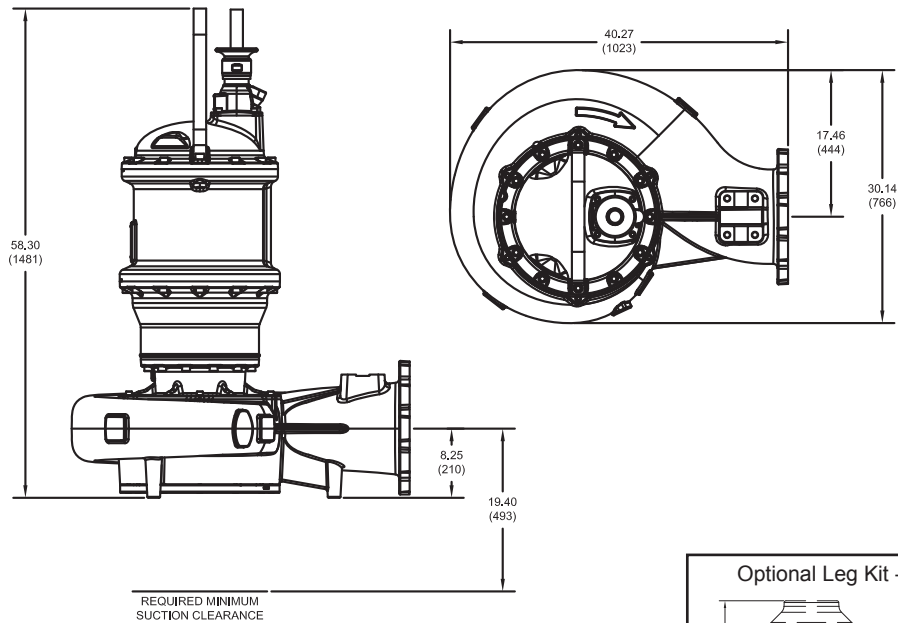

Model No.	Imp. Dia. inches (mm)	HP	Volt	PH	Hz	RPM	NEMA Start Code	Full Load Amps	S.F.	S.F. Amps	Locked Rotor Amps	Cord P/N ▲	Cord Size
7366*-X70-95-32N	12.40 (315)	50.0	460	3	60	1150	H	76.4	1.15	84.0	400.0	138318	6/4 - 18/4
7366*-X70-1E-32N	12.40 (315)	50.0	575	3	60	1150	H	61.2	1.15	67.2	320.0	138318	6/4 - 18/4
7366*-X70-96-32N	13.00 (330)	60.0	460	3	60	1150	F	86.7	1.15	96.8	400.0	138319	2/4 - 18/4
7366*-X70-1F-32N	13.00 (330)	60.0	575	3	60	1150	F	69.4	1.15	77.4	320.0	138318	6/4 - 18/4
7366*-X70-67-32N	13.78 (350)	75.0	460	3	60	1150	H	109.3	1.15	119.5	612.0	138319	2/4 - 18/4
7366*-X70-82-32N	13.78 (350)	75.0	575	3	60	1150	H	87.4	1.15	95.6	489.6	138319	2/4 - 18/4
7366*-X70-68-32N	14.76 (375)	100.0	460	3	60	1150	E	135.0	1.0	135.0	612.0	138319	2/4 - 18/4
7366*-X70-83-32N	14.76 (375)	100.0	575	3	60	1150	E	108.0	1.0	108.0	489.6	138319	2/4 - 18/4

**IMPORTANT !**

Moisture and Temperature sensor leads are integral to power cord.  
 Pump rated for operation at ± 10% voltage at motor.

- ▲ Cord Suffix: XC - 30 Feet, XF - 50 Feet, XJ - 75 Feet, or XL - 100 Feet.
- ▲ Cord sold separately.

SECTION 42B  
 PAGE 74  
 DATE

**CRANE**®

A Crane Co. Company

PUMPS & SYSTEMS

USA: (937) 778-8947 • Canada: (905) 457-6223 • International: (937) 615-3598