



MODEL 165-30
PORTABLE DIAPHRAGM PUMP KITS
One Gallon Per Stroke



165AL-30-200



Optional Carrying and Storage Bag
 Order # 275-31

- ONE GALLON PER STROKE
- VOLUMES TO 30 GPM
- POWERFUL VACUUM LIFTS
- DRY START SUCTION LIFT TO 12'
- PUMP UP TO 50% SOLIDS
- LOW EMULSIVE & SHEER ACTION
- NON-CLOGGING FLOW-THRU DESIGN
- EASY TO SET-UP, USE, CLEAN, AND MAINTAIN
- BUILT TOUGH FOR YEARS OF SERVICE
- LONG LIFE, REINFORCED PUMP DIAPHRAGMS

Edson's 30 gallon per minute Manual Portable Pump Kits are a complete pumping system. The Model 117AL Aluminum Lever-Action Side Inlet Pumps mounted on an Edson Carrying Board, with quick clamp hose couplings, 20 feet of flexible hose, and a 32" Drive Handle makes up the standard kits **Order No. 165AL. Available in both**

The quick clamp couplings, installed on the hose, make it quick and easy to set up the pump kits for use and to disassemble the kit for storage. For specific needs, Edson will customize you Manual Portable Pump Kits with additional hose, bronze strainers and hose couplings. For pumping materials that required rubber and/or pump wetted surfaces with different chemical resistant properties, Edson offers optional diaphragms and valves made of Viton and Hypalon, along with special Halar and Polyurethane coatings for the metal surfaces.

Performance:

Static Suction Lift	15ft./4.57m
Dry Suction Lift	12ft./3.65m
Discharge Head	15ft./4.577m
Max Volume	30 GPM/76 LPM*

*at 30 Strokes Per Min.

Ports Size:

	Choice of:
Inlet	1 1/2" or 2" Male NPT
Discharge	1 1/2" or 2" Female NPT

Construction:

Pump Base	Anodized Aluminum
Diaphragms & Valves.....	Choice of: Nitrile Viton® Hypalon®
Carry Board	16" X 32" X 3/4" Marine Grade Plywood
Hardware Material	Stainless Steel
Portable Pump Kit Hose	20' Flexible Hose w/Quick Clamp Fittings & Adapters

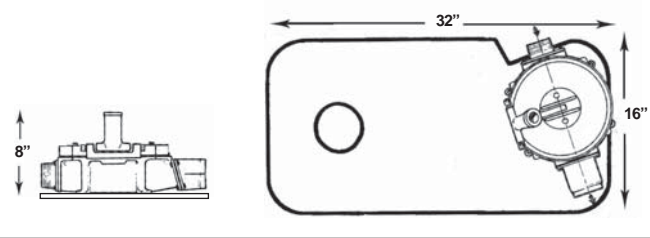

Description	Material	Port Sz	Weight Lb / Kg	Order NO
Manual Pump Kit 30	Aluminum	2"	25 / 11.3	165AL-30-200
Manual Pump Kit 30	Aluminum	1 1/2"	23 / 10.4	165AL-30-150

Options

Diaphragm & Valves	Viton®	230-1130V
Diaphragm & Valves	Hypalon®	230-1130H

Viton® and Hypalon® is a registered trademark of DuPont Dow Elastomers L.L.C.



APPLICATIONS

Edson Portable Diaphragm Pump Kits are the most popular of all Edson manual pumps due to their size, capacity, and versatility. They are used for the collection and transfer of waste liquids and pumping liquids with suspended solids. They are capable of handling liquids with large suspended solids without clogging, to prime from dry starts, and to run dry. These basic performance features combined with The One Gallon Per Stroke performance make them applicable to a very diverse list of applications.

MARINE APPLICATIONS The 165AL-30-200 can be used as a bilge pump, holding-tank pump, wash-down pump, makeshift shower—or all of the above! But its greatest value to the blue water sailor is its ability to pump faster than a scared man with a bucket.

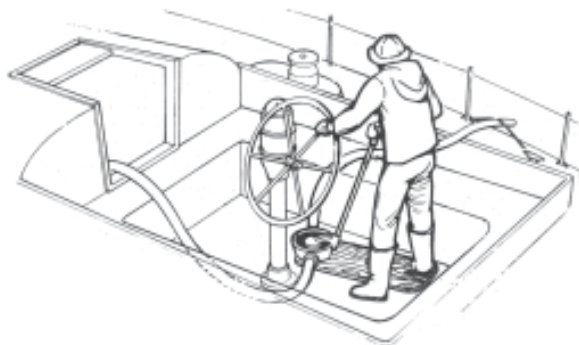

MARINE

- Bilge Pumps
- Emergency Dewatering
- Boatyard Utility Pump
- Oil Spill Cleanup
- Pump out Holding Tanks

INDUSTRIAL

- Sump Pump-Outs
- Slurry Transfer
- Abrasive Pumping
- Oil Spill Cleanup
- Groundwater Removal

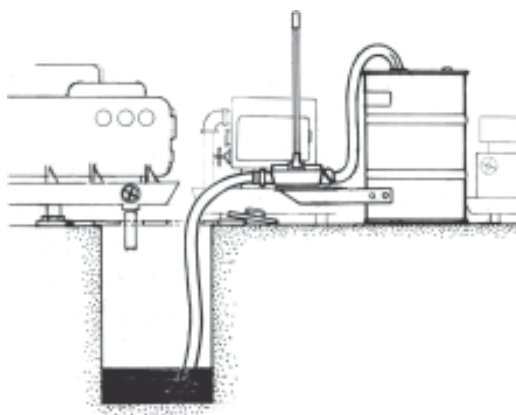

ENVIRONMENTAL

- Tank Pumpouts
- Grease & Oil Collections
- Skimming Pumping
- Asbestos Cleanups
- Oil-Water Separation
- Oil Spill Cleanup

MARINE

MUNICIPAL & UTILITY

- Meter Pit Dewatering
- Manhole Dewatering
- Sewage Collection & Transfer
- Waste Water Skimming
- Drain Clean-out
- Utility Trunk Pump
- Fly Ash Cleanups
- Containment Transfer

