



MODEL 554 MANUAL DIAPHRAGM PUMP

OFFSET DRIVE BOTTOM INLET

One Gallon Per Stroke



554AL-200



554BR-200

- ONE GALLON PER STROKE
- VOLUMES TO 30 GPM
- POWERFUL VACUUM LIFTS
- DRY START SUCTION LIFT TO 12'
- PUMP UP TO 50% SOLIDS
- LOW EMULSIVE & SHEER ACTION
- NON-CLOGGING FLOW-THRU DESIGN
- EASY TO SET-UP, USE, CLEAN, AND MAINTAIN
- BUILT TOUGH FOR YEARS OF SERVICE
- LONG LIFE, REINFORCED PUMP DIAPHRAGMS

Edson Model 554 Offset Drive Bottom Inlet Pumps, are the bottom inlet version of the Model 557. This offset drive is useful when mounting the pump in an enclosure or behind a wall. It is also helpful when overhead clearance is limited. The pumps use a 32" stainless steel handle to move the diaphragm up and down with an easy back and forth lever-action motion that will pump **1 GALLON PER STROKE**.

For pumping materials that required rubber and/or pump wetted surfaces with different chemical resistant properties, Edson offers aluminum and bronze versions of the pump and optional diaphragms and valves made of Nitrile, Viton and Hypalon.

With a self priming suction lift of 12 ft the 554 pumps can lift liquids that are well below the level of the pump. This feature combined with a 2" flow thru design of the diaphragm pump make it ideal for pumping liquids with large suspend solids.

"IF IT FLOWSTHRUTHE HOSE, IT WILL GO THRU THE PUMP."

Review the general applications listed on the next page and you will see that this pump can meet a broad range of pumping needs.

If the offset oriented drive arm and handle is not to your liking, consider Model 638 LeverAction Bottom Inlet pumps.

Performance:

Static Suction Lift	15ft./4.57m
Dry Suction Lift	12ft./3.65m
Discharge Head	15ft./4.577m
Max Volume	30 GPM/76 LPM*
	*at 30 Strokes Per Min.

Ports Size:

Inlet	2" or 1 1/2" Male NPT
Discharge	2" or 1 1/2" Female NPT

Construction:

Pump Base	Choice of:
(Wetted Parts)	Anodized Aluminum
	Marine Grade Bronze

Diaphragms & Valves.....	Choice of:
	Nitrile
	Viton®
	Hypalon®

Hardware Material	Stainless Steel
-------------------------	-----------------

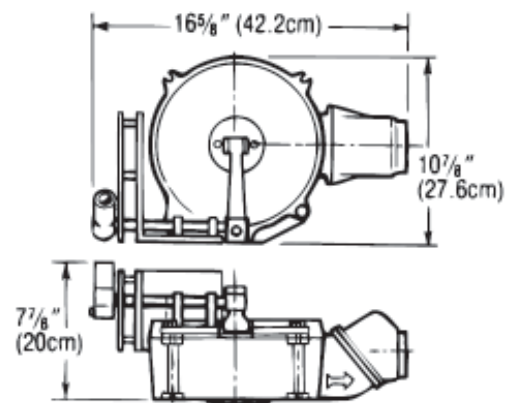

Description	Material	Port Sz	Weight Lb / Kg	Order NO
Offset Drive Bottom Inlet	Aluminum	2"	18 / 8.1	554AL-200
Offset Drive Bottom Inlet	Aluminum	1 1/2"	18 / 8.1	554AL-150
Offset Drive Bottom Inlet	Bronze	2"	39 / 17.7	554BR-200
Offset Drive Bottom Inlet	Bronze	1 1/2"	39 / 17.7	554BR-150

Options

Diaphragm & Valves	Viton®	230-1130V
Diaphragm & Valves	Hypalon®	230-1130H

Viton® and Hypalon® is a registered trademark of DuPont Dow Elastomers L.L.C.



APPLICATIONS Edson Portable Diaphragm Pump Kits are the most popular of all Edson manual pumps due to their size, capacity, and versatility. They are used for the collection and transfer of waste liquids and pumping liquids with suspended solids. They are capable of handling liquids with large suspended solids without clogging, to prime from dry starts, and to run dry. These basic performance features combined with The One Gallon Per Stroke performance make them applicable to a very diverse list of applications.

MARINE APPLICATIONS The 165AL-30-200 can be used as a bilge pump, holding-tank pump, wash-down pump, makeshift shower—or all of the above! But its greatest value to the blue water sailor is its ability to pump faster than a scared man with a bucket.

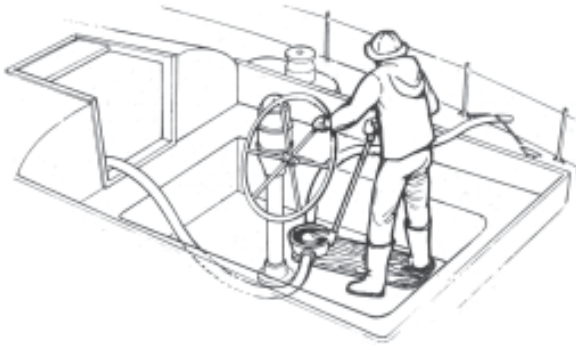

MARINE

- Bilge Pumps
- Emergency Dewatering
- Boatyard Utility Pump
- Oil Spill Cleanup
- Pump out Holding Tanks

INDUSTRIAL

- Sump Pump-Outs
- Slurry Transfer
- Abrasive Pumping
- Oil Spill Cleanup
- Groundwater Removal

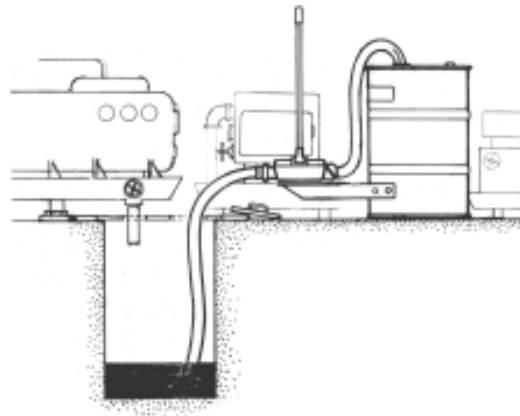

ENVIRONMENTAL

- Tank Pumpouts
- Grease & Oil Collections
- Skimming Pumping
- Asbestos Cleanups
- Oil-Water Separation
- Oil Spill Cleanup

MARINE

MUNICIPAL & UTILITY

- Meter Pit Dewatering
- Manhole Dewatering
- Sewage Collection & Transfer
- Waste Water Skimming
- Drain Clean-out
- Utility Trunk Pump
- Fly Ash Cleanups
- Containment Transfer

