



This document provides technical information relating to this specific Flojet model. General information, references and further resource locations are also included. Triplex industrial pumps are designed to be durable and long-lasting, capable of satisfying pumping needs for a wide variety of applications. Typical pump uses are liquid transfer, spraying, cooling, circulation, filtration and dispensing.

Features

- Robust design with permanent magnet motor
- Long life co-injection mold diaphragm
- Efficient, quiet operation
- Self-priming up to 8 ft. (2.4 m)
- Runs dry without damage

Contents

| | |
|-------------------|--|
| Pump unit: | Triplex 115V 1.5GPM S/E 100PSI BP Triplex 115V 5.7LPM S/E 6.9BAR BP |
| Port fittings: | Not Included |
| Strainer: | Not included |
| IOM: | Included (PN 81000409) |
| Carton type: | Plain box |
| Master pack qty.: | 6 |

Dimensional drawing

Inches [mm]

Notes: Additional envelope space required to allow wires to bend, port fittings and hoses, etc.

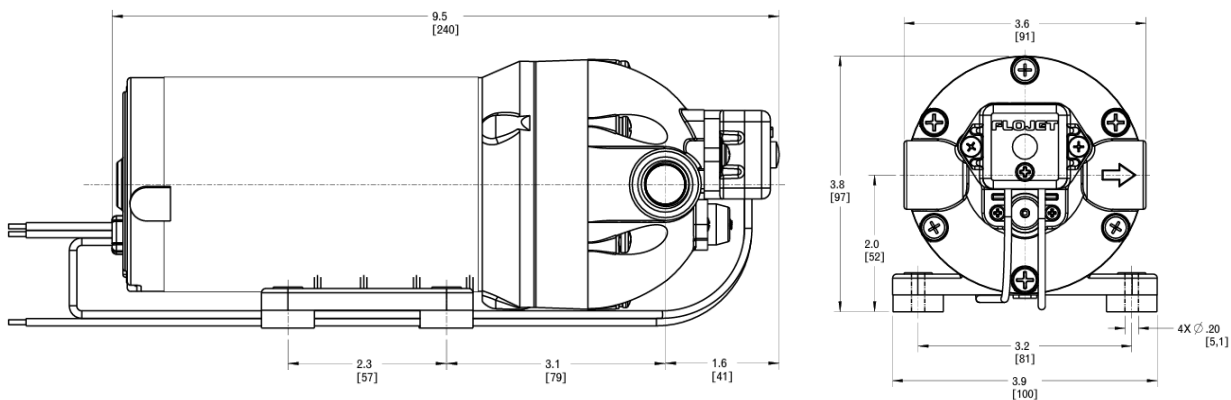

Specifications

General

| | |
|--------------------------|---|
| Part number: | T15FF-71CS-1P |
| Aftermarket replacement: | T15FF-71CS-1P |
| Replaces: | Duplex Series |
| Application: | Industrial fluid transfer & spray |
| Design: | 3 chamber diaphragm 3/8" NPTF ports Permanent magnet motor Noise dampening baseplate Thermal motor protection (TCO) |

Materials (*designates wetted path)

| | |
|------------------------|-----------------------------|
| Upper housing*: | Glass-filled nylon |
| Lower housing: | Cast aluminum |
| Check valve retainer*: | Nylon |
| Diaphragm*: | Santoprene |
| Check valves*: | EPDM |
| Switch diaphragm*: | EPDM |
| Bypass diaphragm*: | EPDM |
| PH seals*: | EPDM |
| PH fasteners: | Stainless steel |
| Baseplate: | Nylon with rubber feet |
| Motor casing: | Cast aluminum; coated steel |

Hydraulic performance (at nominal voltage)

| | |
|--------------------------|-----------------------------|
| Open flowrate: | 1.5 GPM open flow (5.7 LPM) |
| Pressure switch cut-off: | 100 PSI (6.9 BAR) |
| Max operating pressure: | 100 PSI (6.9 BAR) |
| Max inlet pressure: | 30 PSI (2.2 BAR) |
| Internal bypass: | Yes |
| Fluid temperature range: | 40°F - 140°F (4°C - 60°C) |
| Self-priming capability: | Up to 8ft (2.4m) dry prime |
| Run-dry capable: | Yes |

Electrical performance (at nominal voltage)

| | |
|-------------------|------------------------------------|
| Nominal voltage: | 115 VAC |
| Voltage range: | 104 VDC – 126 VDC |
| Max current draw: | 0.8 Amps @ 100 PSI (6.9 BAR) |
| Fuse size: | 1 Amps (required) |
| Duty cycle: | Intermittent (See heat-rise chart) |
| Leads: | 12" (305mm), 18 AWG |
| Wire connection: | Stripped wire |

Compliance

| | |
|--------------------|--------------|
| CE: | No |
| UR: | Yes |
| RCM: | No |
| UKCA: | No |
| WEEE: | No |
| Country of Origin: | Mexico |
| HTS Code: | 8413.50.0050 |

Other information

| | |
|-------------------------|------------------------------------|
| Carton dimensions: | 14.25x 6x4.75" (361x152x121 mm) |
| Master pack dimensions: | 20.12x15.25x10.56" (511x387x268mm) |
| Weight (pump only): | 6 lbs (2.7 kg) |
| UPC code: | 705474224470 |

Flow curve

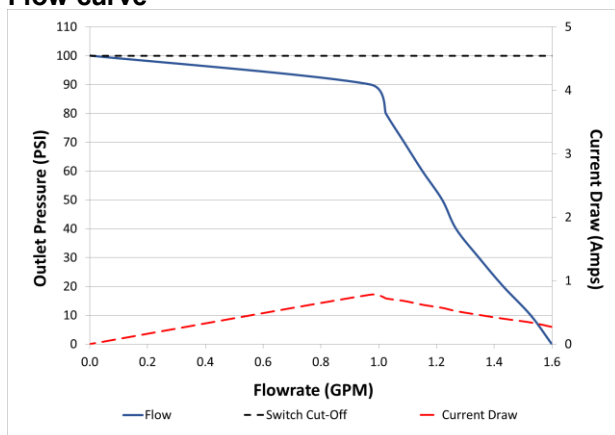

Representative curve of unit operated at nominal voltage. Performance will vary somewhat unit to unit. This model does not have a pressure switch and must be turned off manually. Do not exceed 100 PSI (6.9 BAR). Flow rate at zero pressure represents Open Bucket.

Temperature rise

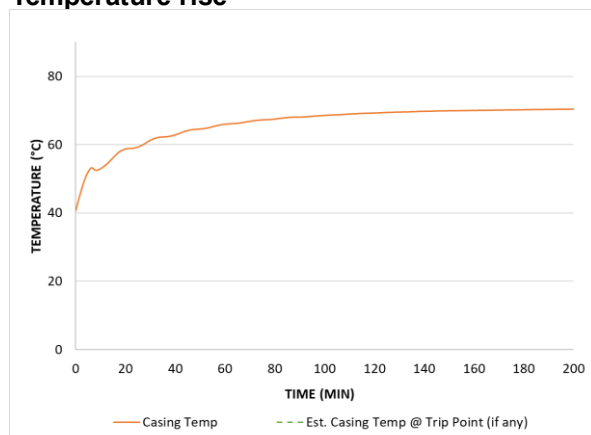

Tested @ ambient temp of 70°F (21°C) @ max run pressure. Est. Casing Temp @ Trip Point may vary (+/-10°C). If there is a concern about the ability of the pump to run continuously for long periods of time, then in application testing is highly recommended.

Pump service kits & spares

| Item | Description |
|--|---|
| 1. Check valve assembly (EPDM): 20407035 | Check valve housing with suction and discharge check valves installed |
| 2. Baseplate/mounting feet: 11028107 | Baseplate w/rubber mounting feet |

Exploded view

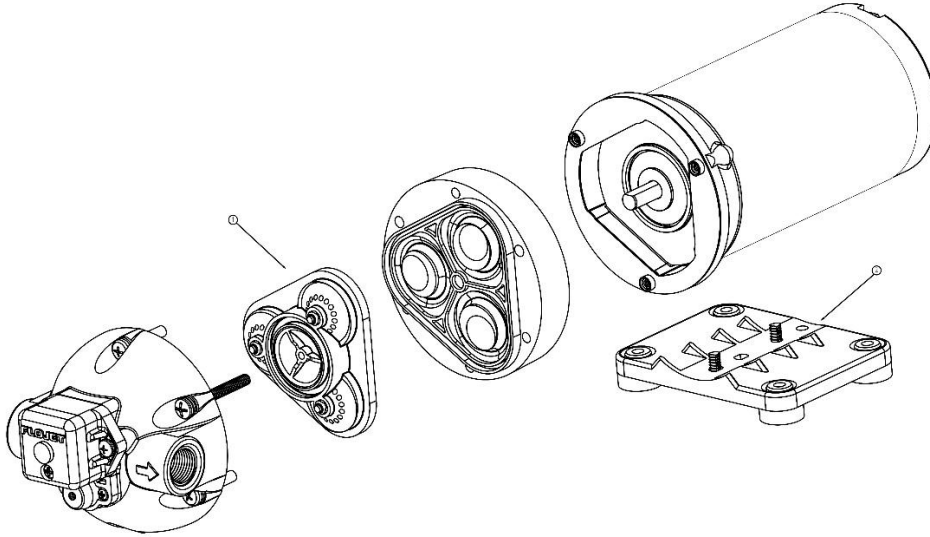

Available Flojet industrial options

In addition to the unit described in this datasheet Flojet also offers the following configurations (will vary somewhat by region and model type) and options:

Voltages: 12, 24, & 36 VDC 115 VAC

Flowrate range: 1 - 6 GPM (3.8 - 22.7 LPM)

Switch setting range: 25 - 150 PSI (1.7 - 10.3 Bar)

Pump configurations:

- Switch; Bypass; Switch & Bypass; Switch, No Bypass; No Switch, No bypass
- EP/PP and other blended diaphragm materials
- EPDM, FKM, and other valve/seal materials
- Some models available with transducers or vacuum switches
- Various customer options dependent on volumes

Installation & operation

For guidance on proper installation and operation of this pump, as well as for any warnings or cautions involving use, please consult the appropriate IOM for the pump. Printed IOMs are supplied with the pumps and are also available online.

Resources & contact information

IOM: On website; hard copies with pumps

Warranty: Information included in IOM

Customer service:

Website:

Refer to contact info at our website

www.xylem.com/flojet

Note: Specifications provided for guidance only. We reserve the right to change specifications without prior notice.