

This document provides technical information relating to this specific Flojet model. General information, references and further resource locations are also included.

VersiJet industrial pumps are designed to be durable and long-lasting, capable of satisfying pumping needs for a wide variety of applications. Typical pump uses are liquid transfer, spraying, cooling, circulation, filtration and dispensing.

Features:

- Heavy duty, coated motor
- Long life co-molded diaphragm
- Efficient, quiet operation
- Self-priming
- Runs dry without damage

Contents:

Pump unit:	VersiJet 115V 4GPM SW 60 PSI BP VersiJet 115V 15LPM SW 4.1BAR BP
Port fittings:	2 X 3/4" (19mm) straight hosebarb
Strainer:	Not included
IOM:	Included (PN 81000480)
Carton type:	Plain box
Master pack qty:	4

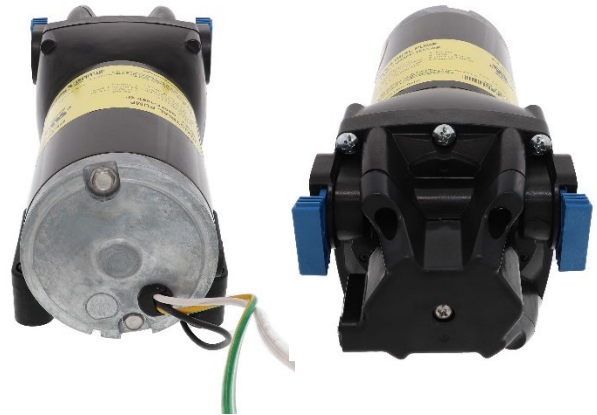

Dimensional Drawing

Notes: Inches [mm]

Additional envelope space required to allow port clips to extend, wires to bend, port fittings and hoses, etc.

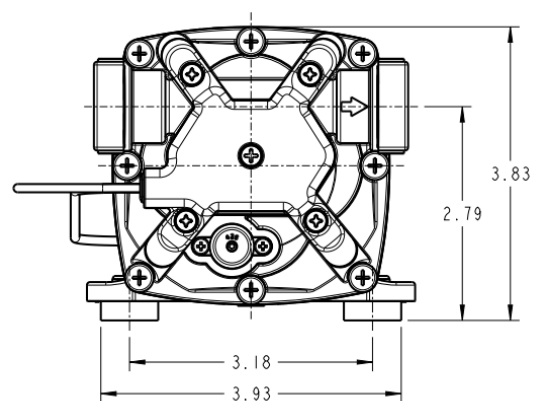
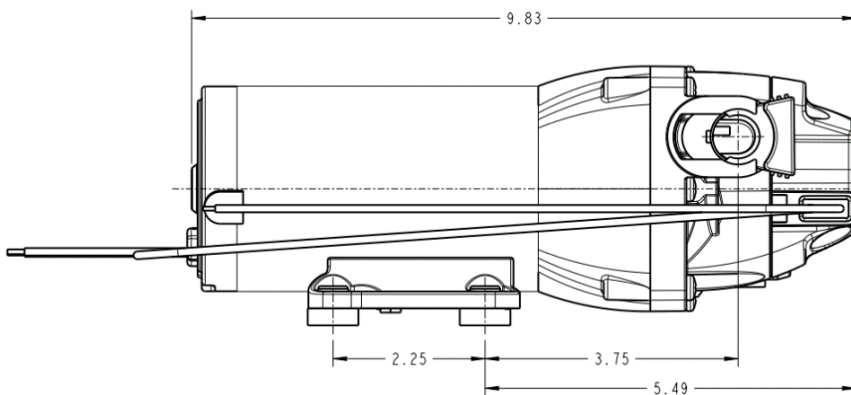

Specifications:

General

Part Number:	Q40FF-118S-2P
Aftermarket replacement:	Q40FF-118S-2P
Replaces:	04300042A / 04300043A
Application:	Industrial Fluid Transfer & Spray
Design:	4 Chamber Diaphragm Quick Connect Ports TENV Permanent Magnet Motor Noise Dampening Baseplate Thermal Motor Protection (TCO)

Materials (*designates wetted path)

Upper Housing*:	Glass-filled polypropylene
Lower Housing:	Cast Aluminum
Check Valve Retainer*:	Polypropylene
Diaphragm*:	Santoprene
Check Valves*:	EPDM
Switch diaphragm*:	EPDM
Bypass Diaphragm*:	EPDM
PH Seals*:	EPDM
PH Fasteners:	Stainless Steel
Baseplate:	Nylon with Rubber Feet
Motor Casing:	Cast Aluminum; Coated Steel

Hydraulic Performance (at nominal voltage)

Open Flowrate:	4 GPM open flow (15 LPM)
Pressure Switch Cut-Off:	60 PSI (4.1 BAR)
Max Operating Pressure:	60 PSI (4.1 BAR)
Max Inlet Pressure:	30 PSI (2.2 BAR)
Internal Bypass:	Yes
Fluid Temperature Range:	32°F - 140°F (0°C - 60°C)
Self-Priming Capability:	Up to 8ft (2.4m) dry prime
Run-Dry Capable:	Yes

Electrical Performance (at nominal voltage)

Nominal Voltage:	115 VAC
Voltage Range:	18 VDC - 27.2 VDC
Max Current Draw:	1.3 Amps @ 60 PSI (4.1 BAR)
Fuse Size:	Not applicable
Duty Cycle:	Intermittent (See heat-rise chart)
Leads:	12" (305mm), 14 AWG (2.5mm ²)
Wire Connection:	Stripped Wire

Compliance

CE:	No
UR:	Yes
RCM:	No
UKCA:	No
WEEE:	No
Country of Origin:	Mexico
HTS Code:	8413.50.0050

Other Information

Other Information:	Industrial
Ambient Temp Range:	32°F - 140°F (0°C - 60°C)
IP Rating:	IPX6
Carton Dimensions:	11.25x5.47x5.07" (286x139x129mm)
Master Pack Dimensions:	12x12x11.5" (305x305x292mm)
Weight (pump only):	5.2 lbs (2.4 kg)
UPC Code:	705474223619

Flow Curve

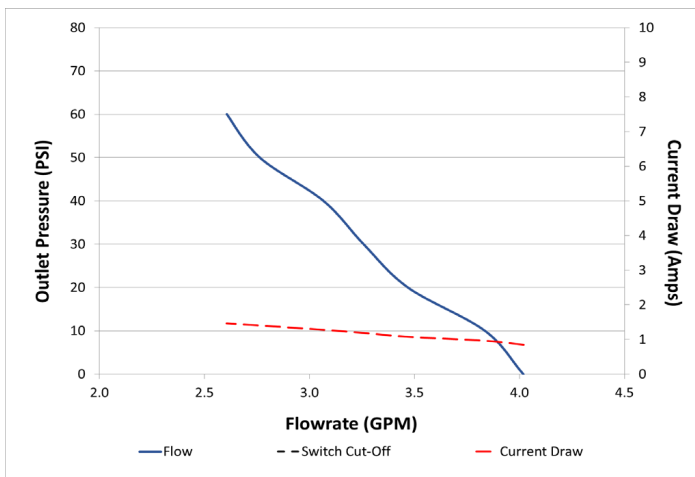

Representative curve of unit operated at nominal voltage. Performance will vary somewhat unit to unit. Switch cut-off represents the point on the flow curve at which the integrated pressure switch will turn off the pump. Flow rate at zero pressure represents Open Bucket.

Temperature Rise

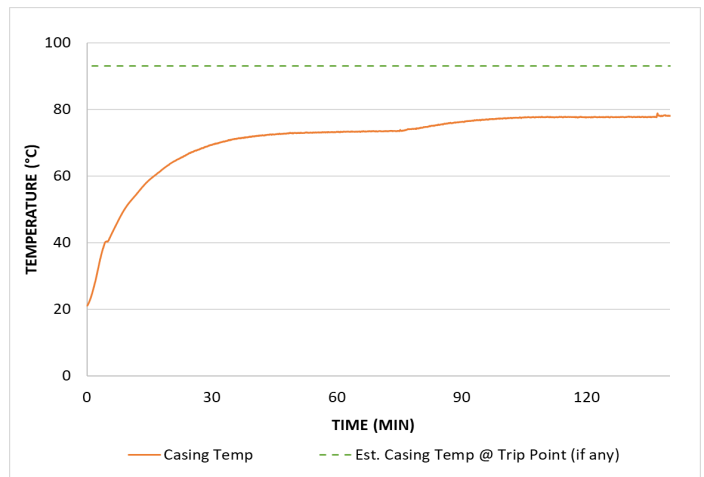

Tested @ elevated ambient temp of 140°F (60°C) @ max run pressure. Est. Casing Temp @ Trip Point may vary (+/-10°C). If there is a concern about the ability of the pump to run continuously for long periods of time, then in-application testing is highly recommended.

Pump Service Kits & Spares:

ITEM	DESCRIPTION
1. Port Clips	2 port clips per kit
2. Check Valve Assembly	Check valve housing with suction and discharge check valves installed
3. Diaphragm/Drive Assembly	Wobble plate/diaphragm assembly
4. Baseplate/Mounting Feet	Baseplate w/rubber mounting feet installed

Exploded View:

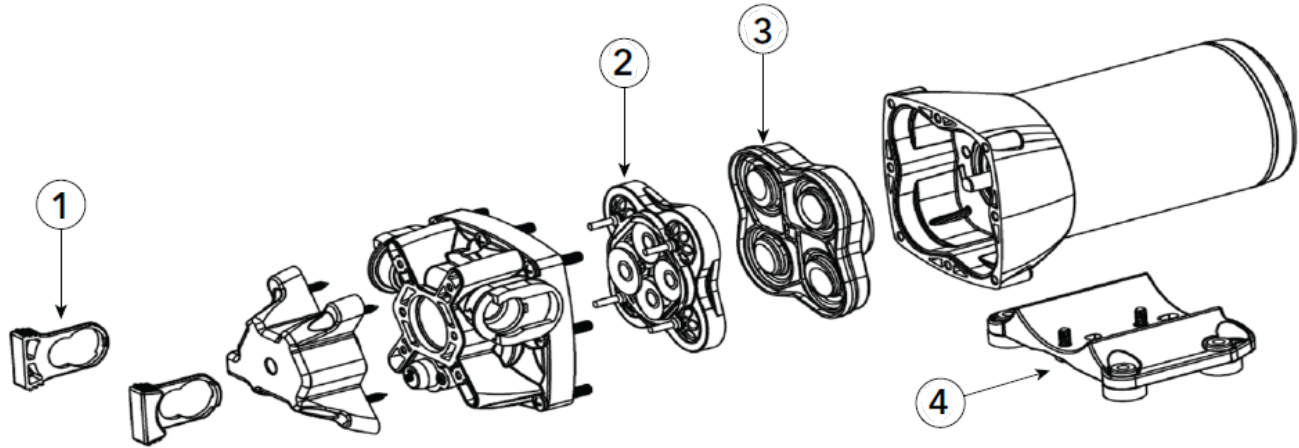

Available Flojet Industrial Options

In addition to the unit described in this datasheet Flojet also offers the following configurations (will vary somewhat by region and model type) and options:

Voltages:	12, 24, & 36 VDC 115 & 230 VAC
Flowrate Range:	1 - 6 GPM (3.8 - 22.7 LPM)
Switch Setting Range:	25 - 150 PSI (1.7 - 10.3 Bar)
Pump Configurations:	Switch; Bypass; Switch & Bypass; Switch, No Bypass; No Switch, No bypass EP/PP and other blended diaphragm materials EPDM, FKM, and other valve/seal materials Some models available with transducers or vacuum switches Various customer options dependent on volumes

Installation and Operation

For guidance on proper installation and operation of this pump, as well as for any warnings or cautions involving use, please consult the appropriate IOM for the pump. Printed IOM's are supplied with the pumps and are also available online.

Resources & Contact Information

IOM: On website; hard copies with pumps

Customer Service: Refer to contact info at our website

Warranty: Information included in IOM

Website: www.xylem.com/Flojet

Note: Specifications provided for guidance only. We reserve the right to change specifications without prior notice.

FLOJET
a xylem brand

Xylem Inc. — USA
17942 Cowan
Irvine, CA 92614

Xylem Inc. — UK
Harlow Innovation Park,
London Road,
Harlow, Essex, CM17 9LX

Xylem Inc. — CHINA
30/F Tower A, 100 Zunyi Road,
Shanghai 200051

Xylem Inc. — HUNGARY KFT
2700 Cegléd
Külso-Kátaí út 41

Xylem Inc. — AUSTRALIA
14 Emporium Avenue
Kemps Creek, NSW 2178

www.xylem.com/flojet

© 2024 Xylem Inc. All rights reserved
Flojet is a trademark of Xylem Inc. or one of its subsidiaries
Q40FF-118S-2P Rev. A 11/2024