

CENTRIFUGAL PUMPS

SERVICE DATA SHEET

A close-coupled pump with wetted Phenolic parts and a Nitrile lip seal or carbon vs. ceramic face mechanical seal. Face seal elastomeric components are constructed from Nitrile.

TROUBLE SHOOTING GUIDE

The trouble shooting guide is a suggestion or aid in helping solve problems that might arise.

NOTE: NEVER WORK ON PUMP WITHOUT MAKING CERTAIN POWER IS OFF

UNIT WILL NOT PUMP:

1. No liquid in pump (requires flooded suction).
Do not run dry.
2. Closed valves or blocked lines.
3. Air lock in suction or discharge lines.
4. Leaking shaft seal.

LOW FLOW:

1. Air leak in suction line.
2. Closed valves or blocked lines.
3. Dirty filter systems.
4. Low voltage.
5. Leaking shaft seal.

MOTOR DOES NOT TURN:

1. No power to motor. Check that all power switches are on. Be sure fuse or circuit breaker is properly set. Timers or controls properly set. Check motor wiring at terminals or plug.

MOTOR RUNS HOT:

These motors will run "hot" to the touch. However, this is normal. Thermal overload protector will function to turn them off if there is an overload or high temperature problem. Excessive heat can be caused by:

1. Low voltage or incorrect voltage.
2. Installed in direct sun.
3. Poor ventilation.

MOTOR THERMAL PROTECTOR OPENS ELECTRIC CIRCUIT:

1. Motor is improperly connected.
2. Low voltage due to under-sized wire or low incoming voltage.
3. Incorrect voltage.
4. Overload due to binding in pump or bad motor bearings.

NOISY OPERATION OF MOTOR:

1. Worn bearings.
2. Damaged cooling fan.

NOISY OPERATION OF PUMP:

1. Air leak in suction line. Bubbles in liquid returning to pump inlet.
2. Restricted suction line due to blockage or under-size pipe.
3. Cavitation. (See 1. & 2. above).
4. Foreign matter in pump impeller.

LEAKS:

1. Loose hose clamps.
2. Leaking gasket. (Tighten screws to approx. 6-10 in.-lbs.).
3. Damaged or broken pump parts.
4. Leaking shaft seal.

WARRANTY

Gorman-Rupp Industries warrants that its pumps are free from defects in materials, workmanship and title. Warranty expires one year from date of shipment. NO WARRANTY OF MERCHANTABILITY OR WARRANTY OF FITNESS FOR USE OR PURPOSE IS IMPLIED AND IS HEREBY EXPRESSLY EXCLUDED.

100 SERIES CENTRIFUGAL PUMP

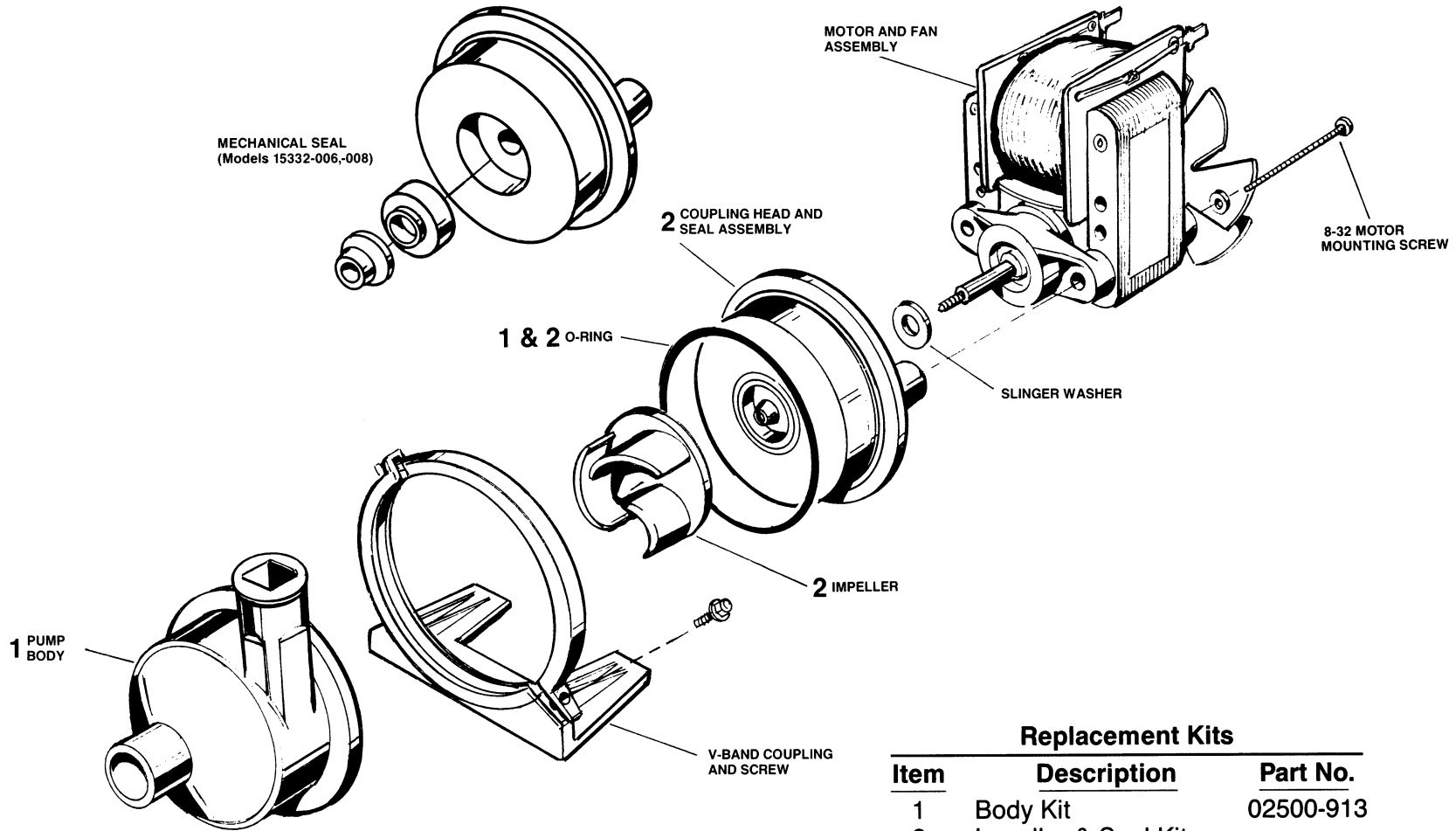

ITEM NUMBERS IDENTIFY PARTS INCLUDED IN REPLACEMENT KITS. CONTACT LOCAL GRI DISTRIBUTOR OR STOCKING REP TO ORDER OR OBTAIN INFORMATION REGARDING OTHER PARTS.

Replacement Kits

Item	Description	Part No.
1	Body Kit	02500-913
2	Impeller & Seal Kit	
	For Lip Seals	02500-930
	For Mechanical Seals	02500-218