

CAD generated and maintained drawing. All printed and electronic copies outside of Griswold's engineering database are "Uncontrolled" and shall be used for reference only.

NOTES: UNLESS OTHERWISE SPECIFIED

1. DIMENSIONS AND TOLERANCES PER ANSI Y14.5M-1982.
2. * INDICATES DIMENSIONS AND/OR FEATURES MODIFIED ON CURRENT REVISION LEVEL.

REV.	DESCRIPTION	BY	APP.	DATE
A	1.5 X 1 - 8 AA ANSI ASSEMBLY	M.H.		

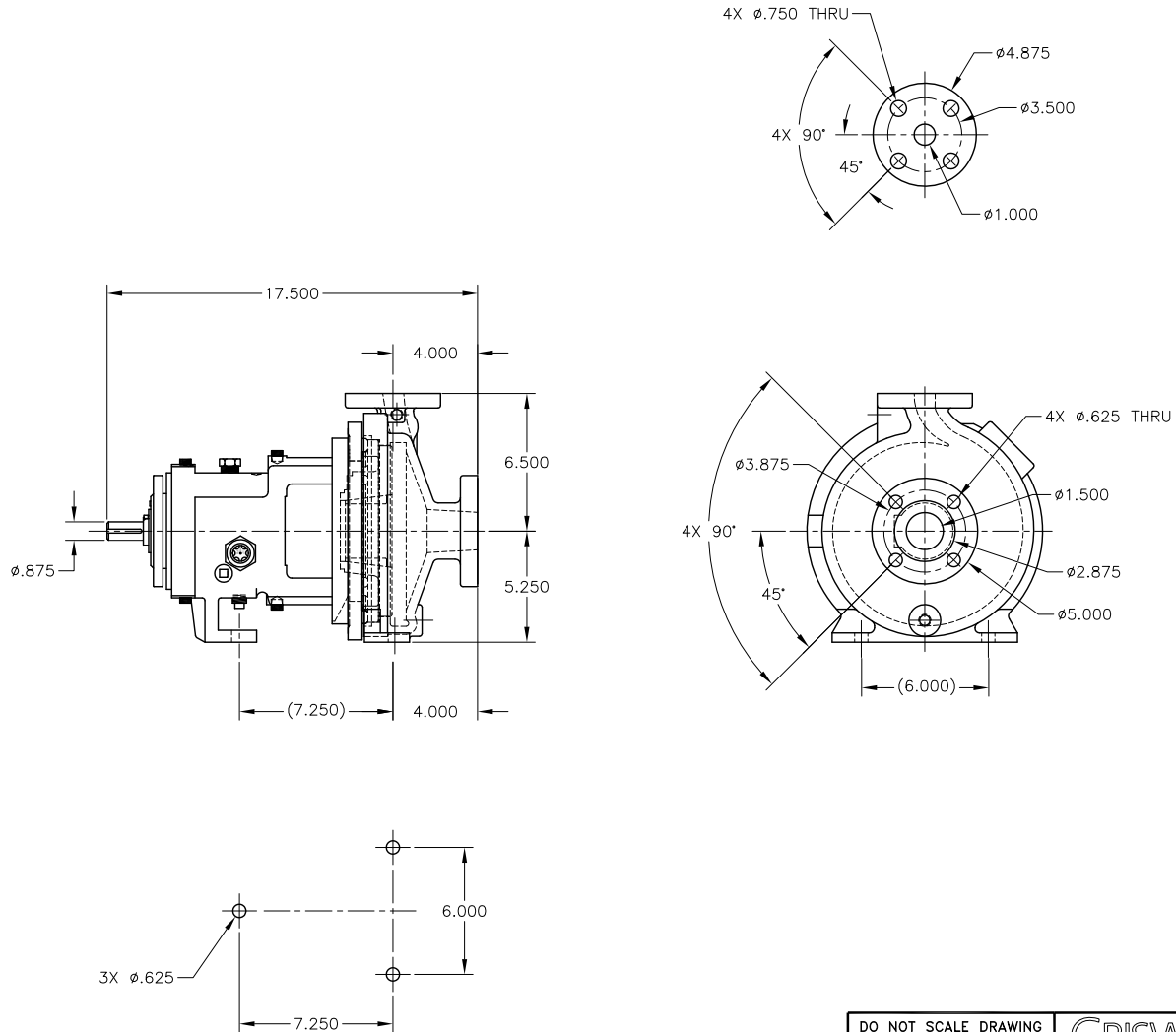

THIS DOCUMENT AND ITS CONTENTS ARE PROPRIETARY TO WILSON PUMP AND ENGINEERING CO. ANY REPRODUCTION, DISCLOSURE OR USE OF THIS DOCUMENT IS EXPRESSLY PROHIBITED EXCEPT AS OTHERWISE AGREED TO IN WRITING.

DO NOT SCALE DRAWING UNLESS OTHERWISE SPECIFIED DIMENSIONS ARE IN INCHES TOLERANCES ARE:		GRISWOLD		GRISWOLD PUMP COMPANY 22080 VAN BUREN ST. GRAND TERRACE, CA 92313 PHONE: (800) 843-9223, FAX: (800) 752-2929	
FRACTIONS	± -	TITLE ASSEMBLY, 1.5 x 1-8 AA ANSI 300# FLANGES			
DECIMALS .XX	± -	DRAWN BY M. HIATT		DATE 04/09/08	ASSY. NO.
.XXX	± -	CHECKED BY		DATE	DRAWING NO. 1.518AA
ANGLES	± -	APPROVED BY		DATE	REV. A
SCALE	1/1	SHEET		1 OF 1	