

CAD generated and maintained drawing. All printed and electronic copies outside of Griswold's engineering database are "Uncontrolled" and shall be used for reference only.

REV.	DESCRIPTION	BY	APP.	DATE
A	4 x 3 - 8 A70 ANSI ASSEMBLY	M.H.		

NOTES: UNLESS OTHERWISE SPECIFIED

1. DIMENSIONS AND TOLERANCES PER ANSI Y14.5M-1982.
2. \* INDICATES DIMENSIONS AND/OR FEATURES MODIFIED ON CURRENT REVISION LEVEL.

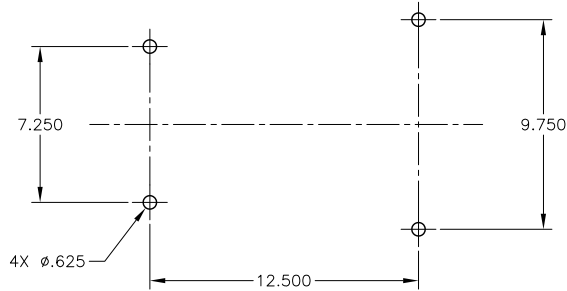
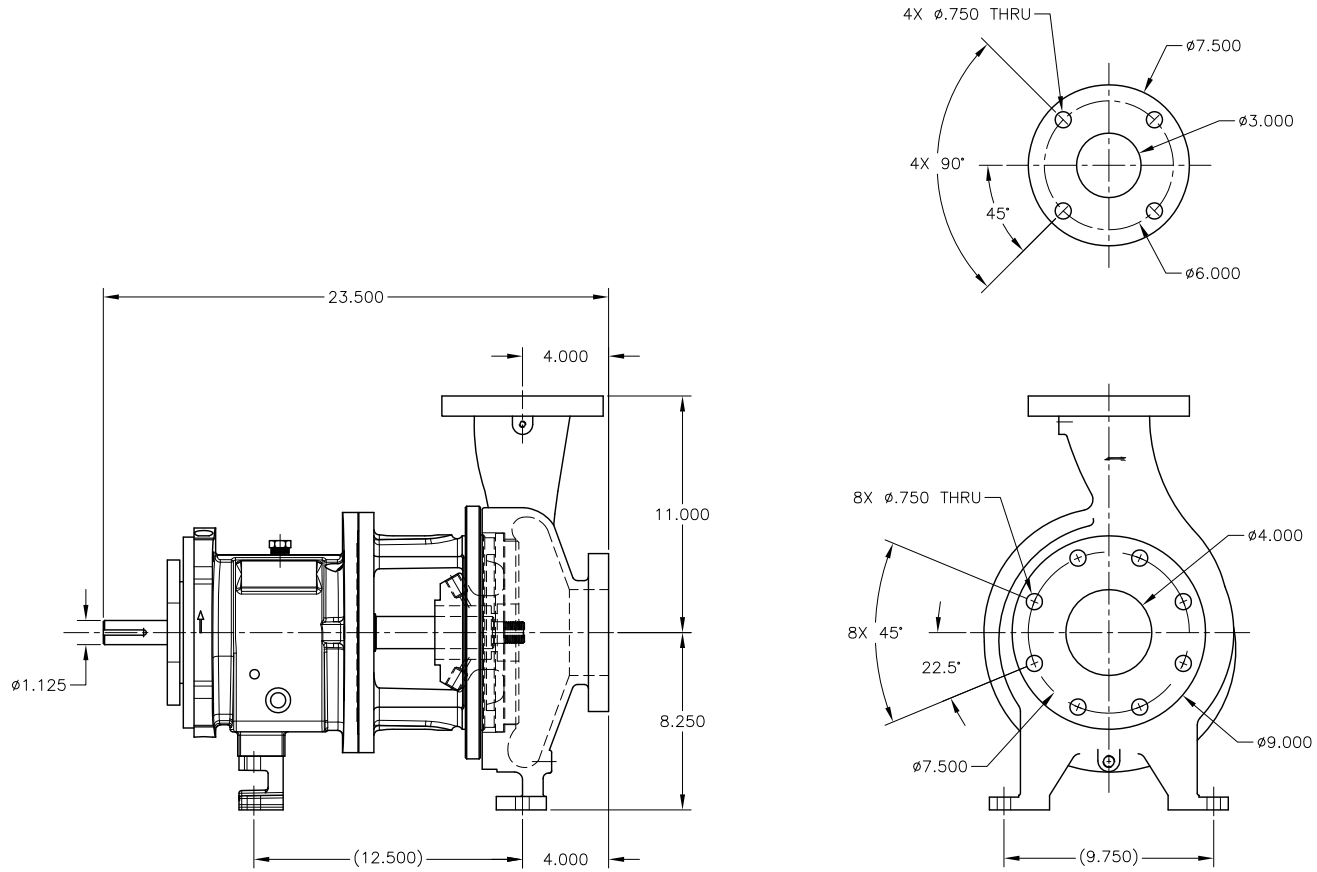

THIS DOCUMENT AND ITS CONTENTS ARE PROPRIETARY TO WILSON PUMP AND ENGINEERING CO. ANY REPRODUCTION, DISCLOSURE OR USE OF THIS DOCUMENT IS EXPRESSLY PROHIBITED EXCEPT AS OTHERWISE AGREED TO IN WRITING.

DO NOT SCALE DRAWING	
UNLESS OTHERWISE SPECIFIED	
DIMENSIONS ARE IN INCHES	
TOLERANCES ARE:	
FRACTIONS	± -
DECIMALS .XX	± -
.XXX	± -
ANGLES	± -
SCALE 1/1	SHEET 1 OF 1

**GRISWOLD**

GRISWOLD PUMP COMPANY  
 22080 VAN BUREN ST.  
 GRAND TERRACE, CA 92313  
 PHONE: (800) 843-9223, FAX: (800) 752-2929

TITLE		ASSEMBLY, 4 X 3 - 8 A70 ANSI	
DRAWN BY	M. HIATT	DATE	10/01/10
CHECKED BY		DATE	
APPROVED BY		DATE	
ASSY. NO.		DRAWING NO.	438A70
REV.	A		