

P-9000 and P-9000-1 ROTARY PUMPS



P-9000 OR P-9000-1 PUMPS

THE CONCEPT

Complies with NSF-61 low-lead standard.

Improved pump design has screw-on seal end cap. P-9000 and P-9000-1 are two-stage self-priming positive displacement pumps. Their construction (bronze, stainless steel, Teflon® and Delrin®) makes them suitable for pumping nearly any non-flammable and non-explosive fluid with low solids content. (Use a GROCO® WSB series strainer if solids are likely to be encountered in the fluid being pumped). External drive is required (1750 RPM max) either direct or with pulley and belt.

The difference between P-9000 and P-9000-1 is the impeller and cam design.

P-9000 is for applications where occasional dry running may be encountered.

P-9000-1 is for lower GPM, higher PSI applications when dry running is not likely.

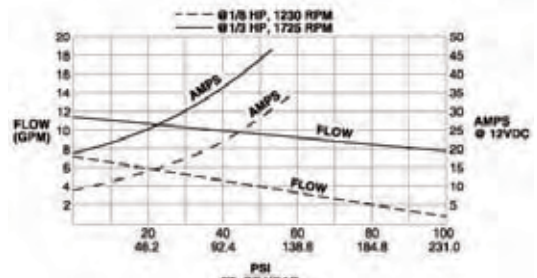
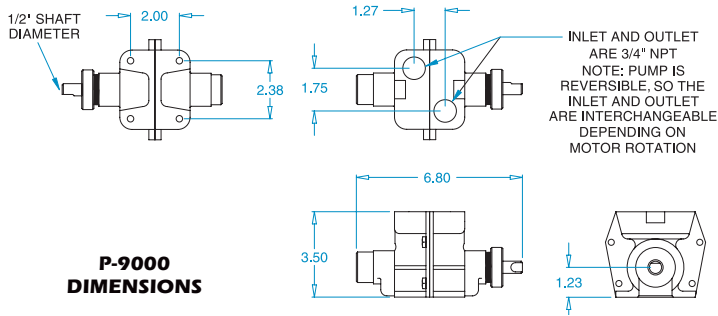

ROTOR PUMP KITS

THE CONCEPT

PJRW and PSRW are comprised of a P-9000 pump and a drive motor, and must be turned on and off by the user, usually with a foot switch or a toggle switch located near the pump. The most common application is for high pressure anchor washdown. No controls, plumbing or dry running protection is included, thus these are the responsibility of the user. Performance is shown in the "P-9000 Performance With Water" graph.

PSRO OR PSRW



PSRO is comprised of a P-9000-1 pump and a drive motor that includes a reversing switch to change the direction of flow. Oil change and fuel transfer are the most common applications. No plumbing or dry running protection is included, thus these are the responsibility of the user. Performance may be calculated from the "P-9000 Performance With Water" graph; P-9000-1 GPM flow will be approximately 75% of P-9000 flow while 50% greater PSI pressure may be achieved.

MODEL	USE FOR	BREAKER	LENGTH	WIDTH	HEIGHT	WEIGHT	PKG	COMMENT
PJRW 12V	Deck Wash	30-amp	8.50"	8.25"	4.50"	13.0#	1	Uses P-9000
PJRW 24V	Deck Wash	15-amp	8.50"	8.25"	4.50"	13.0#	1	Uses P-9000
PSRO 12V	Oil Change	50-amp	20.50"	5.50"	8.25"	37.0#	1	Uses P-9000-1
PSRO 24V	Oil Change	30-amp	20.50"	5.50"	8.25"	37.0#	1	Uses P-9000-1
PSRO 115VAC	Oil Change	10-amp	20.50"	5.50"	8.25"	37.0#	1	Uses P-9000-1
PSRW 12V	Deck Wash	50-amp	20.50"	5.50"	8.25"	37.0#	1	Uses P-9000
PSRW 24V	Deck Wash	30-amp	20.50"	5.50"	8.25"	37.0#	1	Uses P-9000
PSRW 115VAC	Deck Wash	10-amp	20.50"	5.50"	8.25"	37.0#	1	Uses P-9000

PUMP ACCESSORIES

AS-100 BILGE PUMP SWITCH

- Switch turns bilge pump off and on by sensing changes in pressure (caused by rising or falling bilge water level) in its air tube. No floats to stick or fill with water.
- Approximate levels are "ON" at 2-3/4" of bilge level and "OFF" at 1".
- Use with a pump that draws up to 10-amps running continuously or up to 20-amps running intermittently.

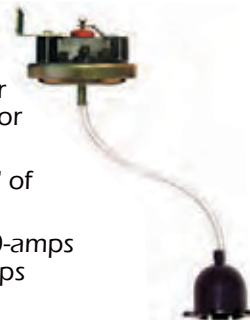

PGN-50 SALT WATER NOZZLE

- The original - the nozzle from which all others are copied.
- Non-corroding plastic nozzle with stainless steel return spring will outlast ordinary hardware store nozzles.
- PGN-50 is standard equipment with C-60 and C-80 deck wash kits.

