

Hydra-Cell[®]

Seal-less Pumps

Versatile, Reliable Pumps for a Wide Range of Applications



M03 Series

- Pumps the full spectrum of low-to-high viscosity fluids.
- Features a seal-less design and horizontal disk check valves that enable the pump to handle abrasives and particulates that might damage or destroy other types of pumps.
- Simple, compact design reduces initial investment and lowers maintenance costs.
- Operational efficiencies reduce energy costs.
- Able to run dry without damage (or additional maintenance) to the pump in case of accident or operator error.
- Tolerates non-ideal operating conditions.
- Minimizes maintenance and downtime because there are no seals, packing or cups to leak or replace.

M03 Series

Maximum Flow Rate: 3.1 gpm (11.7 l/min)

Maximum Pressure: 1200 psi (83 bar) for Metallic Pump Heads
350 psi (24 bar) for Non-metallic Pump Heads



M03 Close-coupled with Brass pump head



M03 Close-coupled with Polypropylene pump head



D03 Shaft-driven with Stainless Steel pump head

M03 Series Performance

Capacities

Flow

Model	Max. Input rpm	Max. Flow @ 1000 psi (69 bar)	
		gpm	l/min
M03-X	1750	3.1	11.7
M03-E	1750	2.2	8.3
M03-S	1750	1.7	6.4
M03-B	1750	1.0	3.6
M03-G	1750	0.6	2.3

Model	Max. Input rpm	@ 1200 psi (83 bar)	
		gpm	l/min
M03-E	1750	2.1	8.1
M03-S	1750	1.6	6.3
M03-B	1750	0.9	3.5
M03-G	1750	0.6	2.2

Pressure

Maximum Inlet Pressure
250 psi (17 bar)

Maximum Discharge Pressure

Metallic Pump Heads:

M03-X to 1000 psi (69 bar)

M03-S, E, B, G to 1200 psi (83 bar)

Non-metallic Pump Heads:

250 psi (17 bar) Polypropylene

350 psi (24 bar) PVDF

Performance and specification ratings apply to M03 Kel-Cell and D03 Shaft-driven configurations unless specifically noted otherwise.

Maximum Flow at Designated Pressure

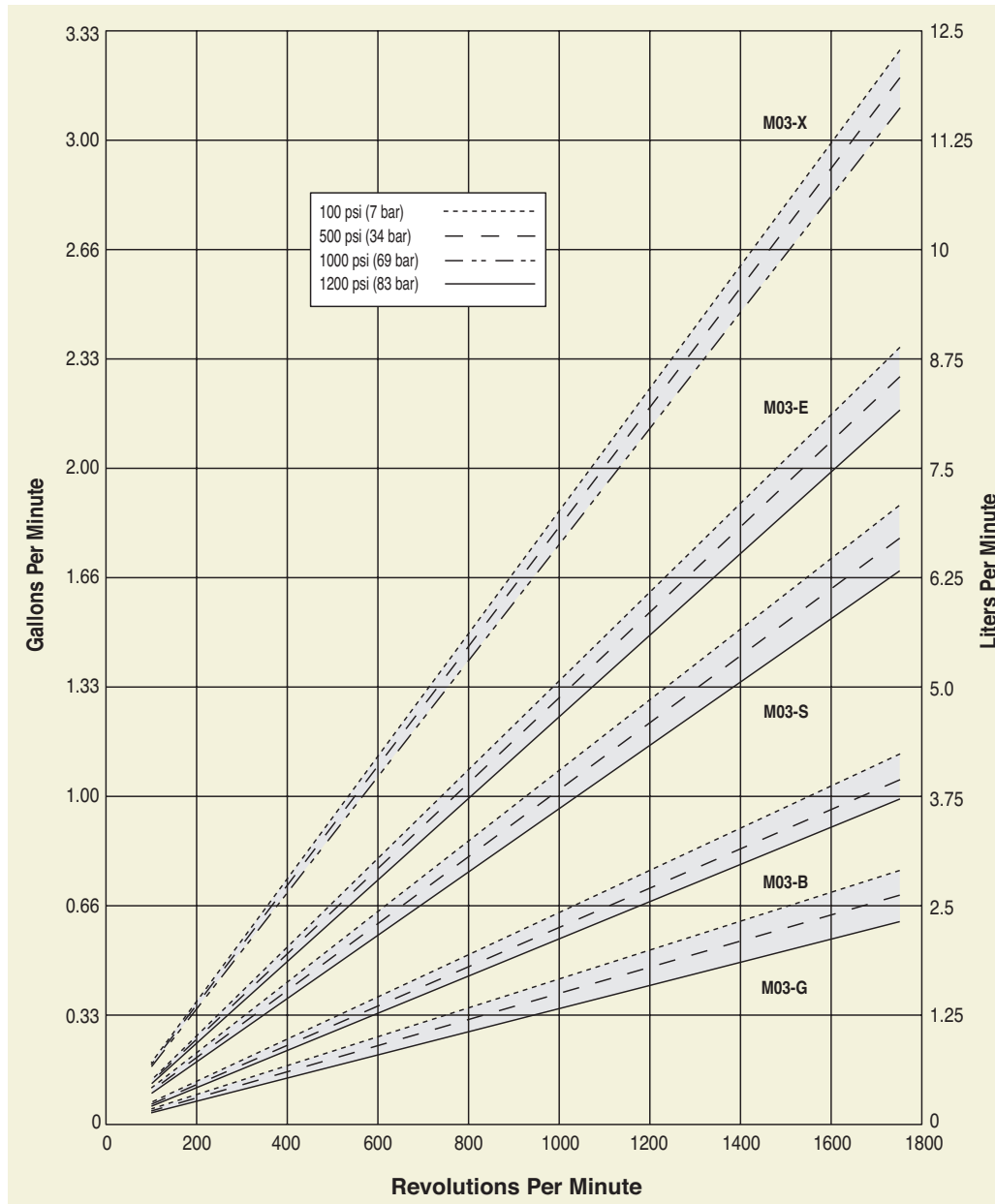

M03 Series Specifications

Flow Capacities @1000 psi (69 bar)

Model	rpm	gpm	l/min
M03-X	1750	3.10	11.73
M03-E	1750	2.18	8.25
M03-S	1750	1.69	6.40
M03-B	1750	0.96	3.63
M03-G	1750	0.62	2.35

Delivery @1200 psi (83 bar)

Model	gal/rev	liters/rev
M03-E	0.0012	0.0046
M03-S	0.0009	0.0036
M03-B	0.0005	0.0020
M03-G	0.0003	0.0013

Delivery @1000 psi (69 bar)

Model	gal/rev	liters/rev
M03-X	0.0018	0.0067
M03-E	0.0013	0.0047
M03-S	0.0010	0.0037
M03-B	0.0005	0.0021
M03-G	0.0004	0.0013

Maximum Discharge Pressure

Metallic Heads:	M03-X to 1000 psi (69 bar)
	M03-S, E, B to 1200 psi (83 bar)
Non-metallic Heads:	250 psi (17 bar) Polypropylene
	350 psi (24 bar) PVDF

Maximum Inlet Pressure 250 psi (17 bar)

Maximum Operating Temperature

Metallic Heads:	250 °F (121 °C) - Consult factory for correct component selection for temperatures from 160 °F (71 °C) to 250 °F (121 °C).
Non-metallic Heads:	140 °F (60 °C)

Maximum Solids Size 200 microns

Inlet Port 1/2 inch NPT

Discharge Port 3/8 inch NPT

Shaft Diameter

M03: 5/8 inch (15.9 mm) hollow shaft
D03: 7/8 inch (22.2 mm)

Shaft Rotation Reverse (bi-directional)

Bearings Precision ball bearings

Oil Capacity 1.0 US quart (0.95 liters)

Weight

Metallic Heads:	28 lbs. (17.7 kg)
Non-metallic Heads:	19 lbs. (8.6 kg)

Calculating Required Power

$$\frac{6 \times \text{rpm}}{63,000} + \frac{\text{gpm} \times \text{psi}}{1,460} = \text{electric motor hp}$$

$$\frac{6 \times \text{rpm}}{84,428} + \frac{\text{l/min} \times \text{bar}}{511} = \text{electric motor kW}$$

When using a variable frequency controller (VFD) calculate the hp or kW at minimum and maximum pump speed to ensure the correct hp or kW motor is selected. Note that motor manufacturers typically de-rate the service factor to 1.0 when operating with a VFD.

Net Positive Suction Head (NPSHr)

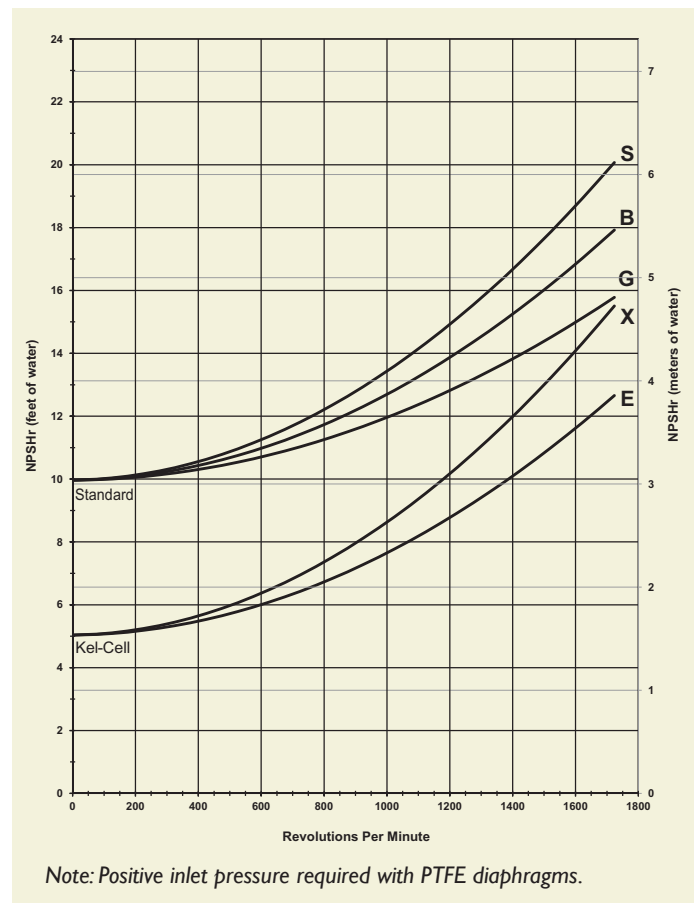

Self-priming:

Each Hydra-Cell pump has different lift capability depending on model size, cam angle, speed, and fluid characteristics. To ensure that your specific lift characteristics are met, refer to the inlet calculations regarding friction, and acceleration head losses in your Hydra-Cell Installation & Service Manual. Compare those calculations to the NPSHr curves above.

M03 Series Representative Drawings

M03 Models with Metallic Pump Head Inches (mm)

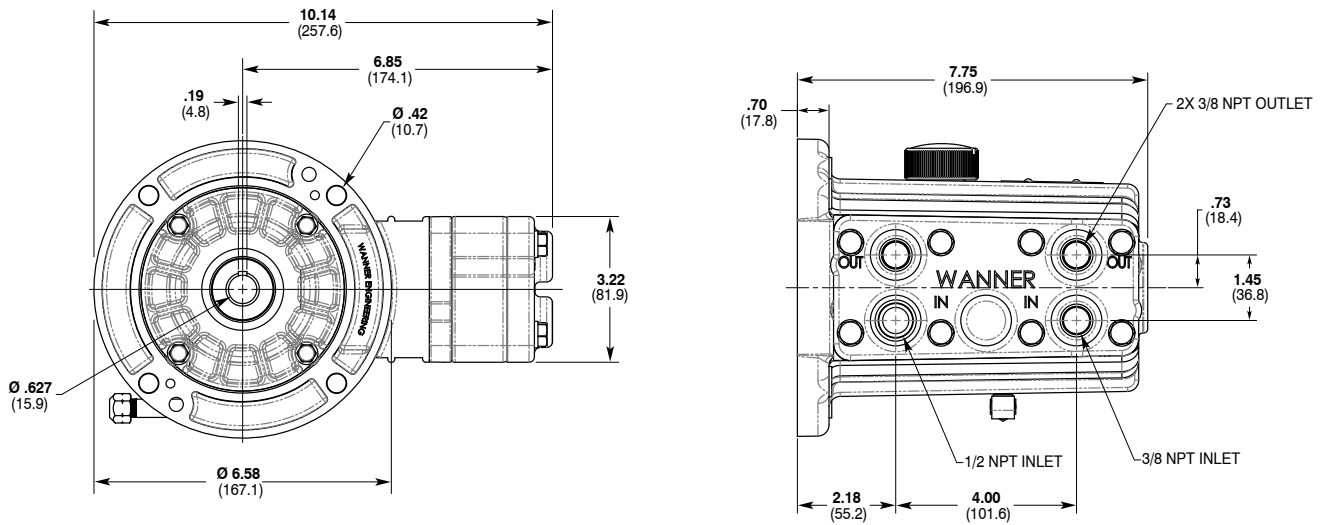

* Add 0.38" (9.65mm) overall length where shown for manifold cover plate on non-metallic models and 0.20" (5.08mm) for bolt heads attaching the plate.

D03 Models with Metallic Pump Head Inches (mm)

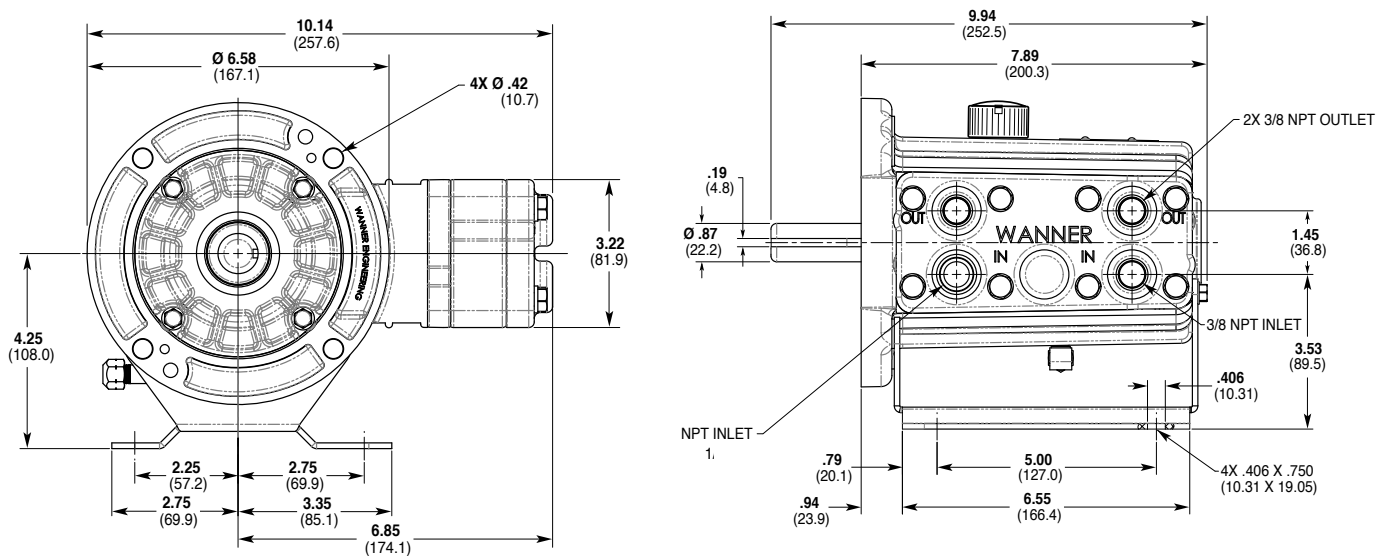

* Add 0.38" (9.65mm) overall length where shown for manifold cover plate on non-metallic models and 0.20" (5.08mm) for bolt heads attaching the plate.

Note: Contact factory for additional drawings of specific models and configurations.

M03 Series Representative Drawings

Pump/Motor Adapter Inches (mm)

Part Number: A04-001-I202

Must be ordered separately for D03 models for use with 56C, I43TC, and I45TC frame motors.

Metric adapter available - consult factory.

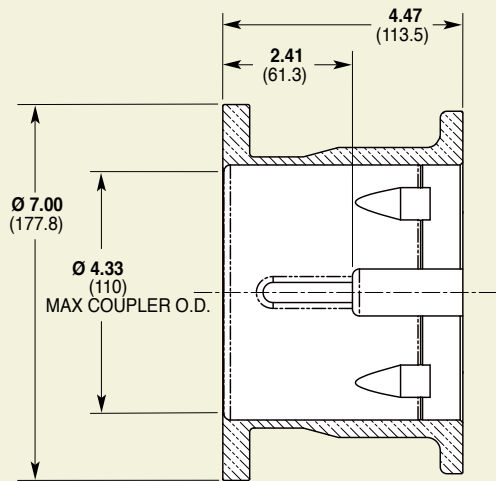

Part Number: A04-002-I202

Must be ordered separately for D03 models for use with I82C, I84TC, and 2I3TC and 2I5TC frame motors.

Metric adapter available - consult factory.

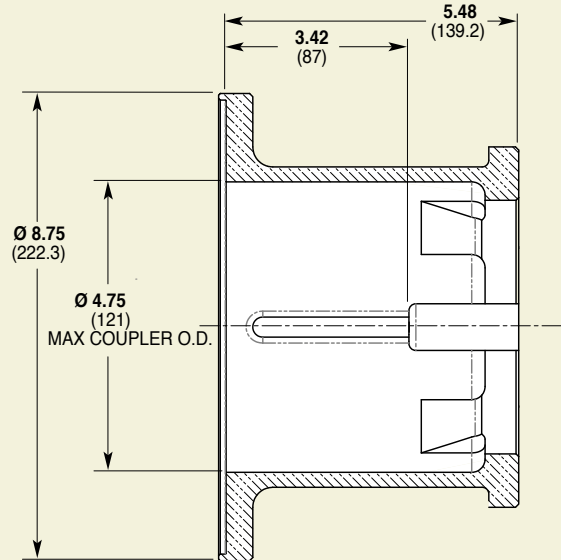

Valve Selection

A Hydra-Cell M03/D03 pumping system uses a C46 Pressure Regulating Valve.



For complete specifications and ordering information, consult the Hydra-Cell Master Catalog.

M03 Series **How to Order**

Ordering Information

1	2	3	4	5	6	7	8	9	10	11	12
---	---	---	---	---	---	---	---	---	----	----	----

A complete M03 Series Model Number contains 12 digits including 9 customer-specified design and materials options, for example: M03XKSTHFECA.

Digit	Order Code	Description
1-3		Pump Configuration
	D03	Shaft-driven (NPT Ports)*
	M03	Close-coupled to NEMA 56C footed motor (NPT Ports) *Pump/motor adapters ordered separately. See previous page.
4		Hydraulic End Cam
	X	Max 3.1 gpm (11.7 l/min) @ 1750 rpm
	E	Max 2.2 gpm (8.3 l/min) @ 1750 rpm
	S	Max 1.7 gpm (6.4 l/min) @ 1750 rpm
	B	Max 1.0 gpm (3.6 l/min) @ 1750 rpm
	G	Max 0.6 gpm (2.3 l/min) @ 1750 rpm
5		Pump Head Version
	A	Standard NPT Ports (S, B & G cams)
	K	Kel-Cell NPT Ports (X & E cams)
6		Pump Head Material
	B	Brass
	M	PVDF
	P	Polypropylene
	S	316 Stainless Steel
	T	Hastelloy CW12MW
7		Diaphragm & O-ring Material
	E	EPDM (requires EPDM-compatible oil - Digit 12 oil code J)
	G	FKM
	J	PTFE (available with X and E cams and standard A version only; cannot be used with Kel-Cell pumps)
	P	Neoprene
	T	Buna-N
8		Valve Seat Material
	C	Ceramic
	D	Tungsten Carbide
	H	17-4 Stainless Steel
	S	316L Stainless Steel
	T	Hastelloy C

Digit	Order Code	Description
9		Valve Material
	C	Ceramic
	D	Tungsten Carbide
	F	17-4 Stainless Steel
	N	Nitronic 50
	T	Hastelloy C
10		Valve Springs
	E	Elgiloy
	S	316L Stainless Steel
	T	Hastelloy C
11		Valve Spring Retainers
	C	Celcon
	H	17-7 Stainless Steel
	M	PVDF
	P	Polypropylene
	T	Hastelloy C
	Y	Nylon
12		Hydra-Oil
	A	10W30 standard-duty oil
	G	5W30 cold-temp severe-duty synthetic oil
	J	EPDM-compatible oil
	K	Food-contact oil

Consult the Hydra-Cell Master Catalog for:

- Motors, bases, couplings and other pump accessories
- Hydra-Oil selection and specification information
- Design considerations, installation guidelines, and other technical assistance in pump selection

Hydra-Cell[®]

Seal-less Pumps



Wanner Engineering, Inc.

World Headquarters & Manufacturing

Wanner Engineering, Inc.
1204 Chestnut Avenue,
Minneapolis, MN 55403 USA
Phone: 612-332-5681 • Fax: 612-332-6937
Toll-Free Fax (USA): 800-332-6812
Email: sales@wannereng.com
www.Hydra-Cell.com

207 US Highway 281
Wichita Falls, TX 76310 USA
Phone: 940-322-7111
Toll-Free: 800-234-1384
Email: sales@wannereng.com
www.Hydra-Cell.com

Latin American Office

R. Álvaro Anes, 150 Bairro Campestre
Santo André/São Paulo, Brazil - CEP 09070-030
Phone: (11) 4081-7098
Email: mmagoni@wannereng.com
www.Hydra-Cell.com



Wanner International Ltd.

Wanner International, Ltd.
Hampshire - United Kingdom
Phone: +44 (0) 1252 816847
Email: sales@wannerint.com
www.Hydra-Cell.eu



Wanner Pumps Ltd.

Wanner Pumps, Ltd.
Kowloon - Hong Kong
Phone: +852 3428 6534
Email: sales@wannerpumps.com
www.WannerPumps.com

Shanghai - China
Phone: +86-21-6876 3700
Email: sales@wannerpumps.com
www.WannerPumps.com

Guangzhou - China
Phone: +86-20-8920 2730
Email: sales@wannerpumps.com
www.WannerPumps.com

