

# Hydra-Cell®

## Industrial Pumps

### Oil Level Monitoring Mounting Kit

- *Ideal for remote or critical industrial applications such as oil fields, paper mills and automotive plants*
- *Detects dramatic change to the pump's oil level to minimize costly industrial process interruptions and potential pump damage*
- *Works with all Wanner Hydra-Cell pumps*



The Hydra-Cell Oil Level Monitoring System utilizes a Murphy Switchgauge Model L129CK1. Field proven in the oil industry to detect crank case oil level, the Murphy Switch is well suited to detect oil level for Hydra-Cell pumps such as the D-35 shown here.

# Hydra-Cell®

**SIMPLY BUILT TO LAST**

When we say "Simply Built to Last", we mean it! Wanner Engineering Hydra-Cell pumps with the Oil Level Monitor Kit provide maximum performance and reliability in some of the toughest industrial equipment and processes:

- Hot fluids
- Reclaim water
- Corrosive fluids
- Slurries
- Abrasives
- Liquid gases
- Wettable powders
- Fertilizers
- Cutting fluids
- Viscous fluids
- Ultrapure fluids
- Chemicals
- Adhesives
- Soap solutions
- Salt water
- and many more...

## Specialized Design.

For many years, Hydra-Cell customers have used oil level monitors for their critical or remote industrial applications. Now, Wanner Engineering has designed a compact, rugged, ready-to-go mounting kit to monitor pump oil level using a Murphy Switchgag.

## Dimensions

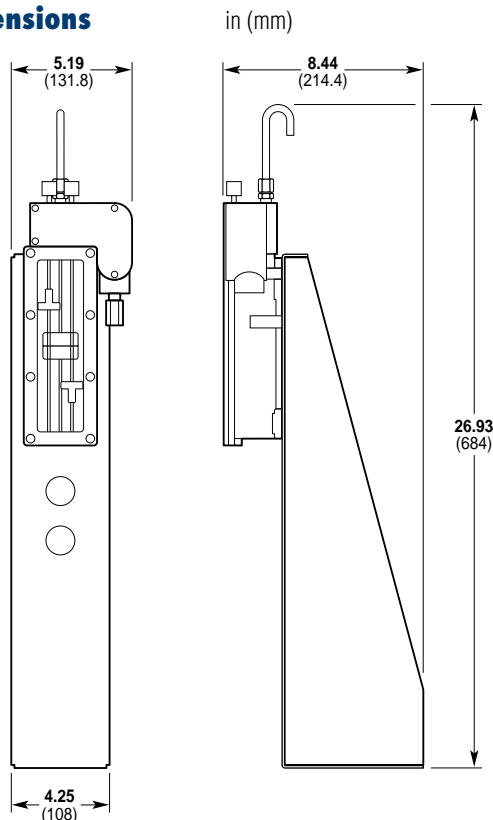

# Oil Level Monitoring Mounting Kit

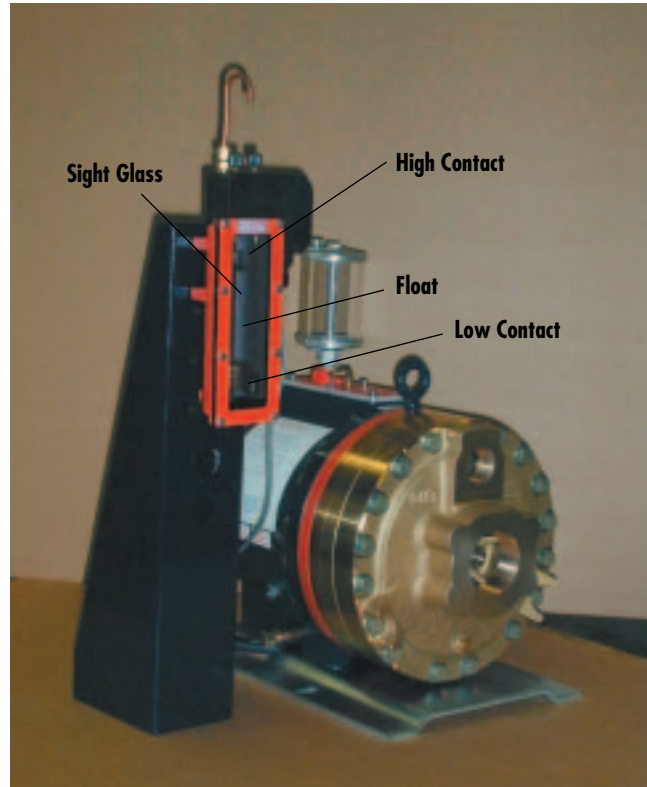

In remote applications such as an oil field or critical applications such as a paper mill, detecting a sudden, radical change in pump oil level can save the pump from severe damage and more importantly, minimize costly interruptions to the process.

The Oil Level Monitor Mounting Kit is easy to assemble and can be used with all Hydra-Cell pumps. The Oil Level Mounting kit includes the switch mounting bracket and all necessary hardware. The Murphy Switch, Model L129CK1 is sold separately.

## Oil Level Monitoring Mounting Kit

<b>Part Number</b>	103-000
--------------------	---------

## Wanner Engineering, Inc.

1204 Chestnut Avenue, Minneapolis, MN 55403 USA  
 (612) 332-5681 FAX (612) 332-6937  
 Toll Free FAX (USA only) (800) 332-6812  
 Email: sales@wannereng.com  
 Website: www.hydra-cell.com  
 Document Fax Back System: (510) 745-0440

## Wanner International Ltd.

Grange Court, Grange Road  
 Tongham, Surrey GU10 1DW, England  
 Tel +44 (0) 1252 781234  
 FAX Tel +44 (0) 1252 781235  
 Email: sales@wannerint.com