



Sensor-Max II

5 GPM variable speed freshwater pump

Exceptional performance and life for total peace of mind with your onboard water system.

The Sensor-Max II is our most sophisticated freshwater delivery pump featuring variable speed technology. The Sensor-Max II incorporates our high performance five chamber design with advanced pressure sensor and variable speed programming that automatically adjusts the motor speed to deliver the right flow and pressure the water system requires. The result is an extremely quiet pump operating smoothly in the background for a truly exceptional onboard experience for total peace of mind while at sea.



- Quiet operation with no water hammer
- Consistent pressure and smooth, steady flow
- Eliminates need for accumulator tank
- High flow capacity, supplies up to five outlets
- Conserves power by adjusting motor speed as needed
- Robust co-molded diaphragm and cast aluminum lower housing for long life



What our customers have to say about the Sensor-Max II

“I like the lower (quieter) tone and smooth ramp up and ramp down when using the pump.”

Mike, Massachusetts, USA

“The Sensor-Max II helped with not having to coordinate water usage. Being able to run more than one outlet at a time is great.”

Justin, New Mexico, USA

“I appreciate the ability to operate at low rpm with low noise when low volume flow is needed. Being mounted on a bulkhead with a stateroom on the opposite side makes quiet operation appreciated.”

Brad, Florida, USA

Sensor-Max II testimonials were received via feedback surveys from customer product testers who received the product for free. They are individual experiences, reflecting real life experiences of those who tested the product. Individual results may vary. Testimonials are not necessarily representative of what anyone else using our product may experience.

Visit our product page to access complete details, including the product datasheet and video.



Specifications

Model	Nominal DC volts	Max amp draw	Open flow GPM (LPM)	Max pressure PSI (bar)	Required fuse
V50AJ-115N-3A	12V DC	12A	5 (19)	40 (2.75)	15A

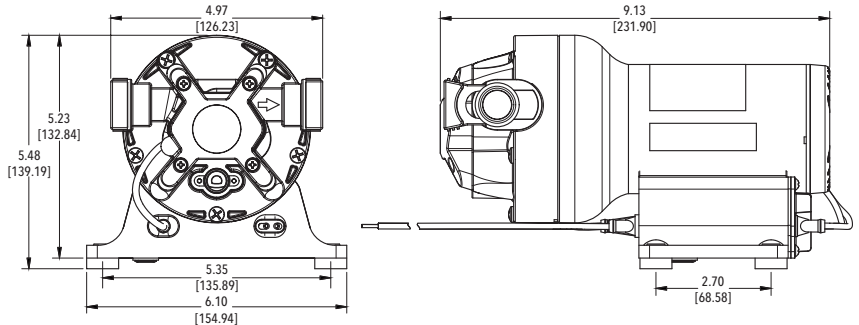

Package includes



Typical installation layout

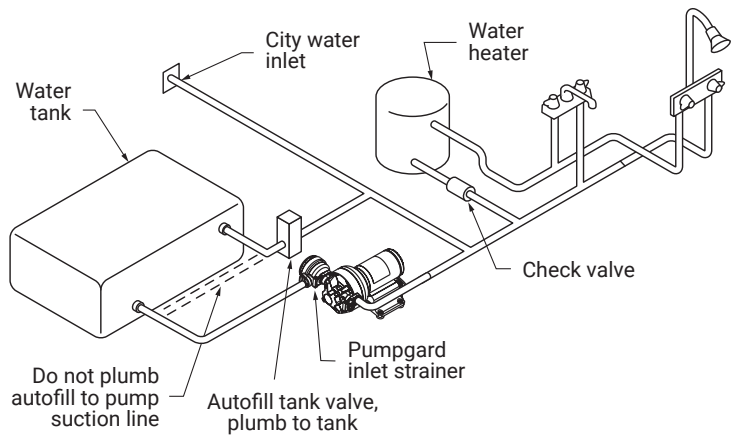

DO NOT INSTALL AN ACCUMULATOR TANK WITH THE SENSOR-MAX II PUMP

If an accumulator tank is installed in your fresh water system, please remove all air pressure by depressing the air valve on top of the accumulator tank.

xylem.com/jabsco