

Instruction Manual

AQUA JET
Water Pressure Systems

WPS 3.4 12/24 V DC

WPS 5.0 12/24 V DC

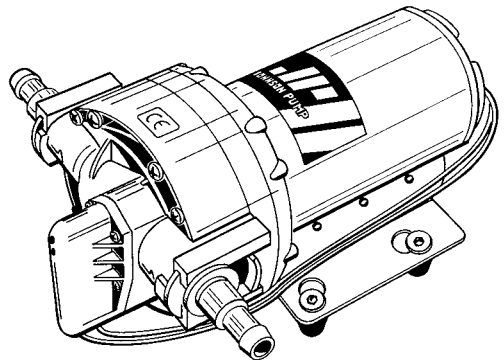

Water Pressure Systems 3.4 and 5.0 mounted to DC motor 12/24 V

Typical applications

The WPS 3.4 and the WPS 5.0 are both five chamber positive displacement diaphragm pumps.

These pumps are the ideal choice for pressurizing water in a closed system such as that found in a boat or in a recreational vehicle.

They can easily build the pressure required for a pressurized water supply system.

Features

- Quiet operation
- Smooth flowing
- Self priming
- Integrated pressure switch turns pump on and off automatically when tap is opened and closed
- Dry running without damage
- Low power consumption
- Quick disconnect fittings

Working principle

As the pump runs, pressure builds until reaching 2.8 bar/41 psi. At this point, the integrated pressure switch automatically shuts the pump off.

The pump is equipped with positively checking outlet valves which ensure that the pressure is maintained after the pump shuts off.

When water is demanded (at the faucet, shower et.c.) the pressure decreases. After a moderate drop in pressure, the integrated pressure switch automatically turns the pump back on.

Due to their durable construction and thoughtful design, the WPS 3.4 and the WPS 5.0 pumps will provide many years of service.

Important! The pressure setting of this pump is made at the factory. Warranty invalidated by pressure switch interference.

Technical description

Body: Nylon/Polypropylene
 Valve housing: Polypropylene
 Valves: Santoprene/EPDM
 Diaphragm: Santoprene
 Connection: 3/8" BSP, 1/2" hose (ø 13 mm) and 1/2" BSP, 3/4" hose (ø 18 mm) or US 3/8" NPT, 1/2" hose (ø 13 mm) and US 1/2" NPT, 3/4" hose (ø 18 mm)

Max. liquid temperature: Max +50°C/+120°F
 Fasteners: Stainless steel
 Max. suction lift: WPS 3.4 – 2 m/6.5 ft
 WPS 5.0 – 2.5 m/8.2 ft
 Cut in pressure: 1.7 Bar/25 psi
 Cut-off pressure: 2.8 Bar/41 psi
 (Other pressure settings see page 39)
 Duty cycle: Intermittent, max 20 min
 Motor: WPS 3.4 – 100 W
 WPS 5.0 – 150 W
 12/24 V DC
 with built in thermal protection

The motor is ignition protected according to ISO 8846 (Small craft – Electrical devices – Protection against ignition of surrounding flammable gases).

Type designation

(See page 39)

Pressure and capacity data

(based on water at +20°C/68°F and at full voltage of the motor)

WPS 3.4

Pressure		Flow			Amp. draw	
Bar	kPa	Psi	l/min	USGPM	12 V	24 V
0	0	0	13	3.4	2.3 A	1 A
0.4	40	6.2	12.2	3.2	3.1 A	1.3 A
0.8	80	11.6	11.4	3	4 A	1.7 A
1.2	120	17.4	10.6	2.8	4.8 A	2.1 A
1.6	160	23.2	9.9	2.6	5.4 A	2.5 A
2	200	29	9.1	2.4	6.2 A	2.8 A
2.4	240	34.8	8.5	2.2	7 A	3.1 A
2.8	280	40.6	7.7	2	8.1 A	3.6 A
Fuse required					10 A	5 A

WPS 5.0

Pressure		Flow			Amp. draw	
Bar	kPa	Psi	l/min	USGPM	12 V	24 V
0	0	0	19.4	5.1	3.9 A	1.6 A
0.4	40	6.2	18.2	4.8	4.9 A	2.1 A
0.8	80	11.6	17	4.5	6 A	2.5 A
1.2	120	17.4	15.8	4.2	7.1 A	3.1 A
1.6	160	23.2	14.7	3.9	8 A	3.6 A
2	200	29	13.5	3.6	9.2 A	4.1 A
2.4	240	34.8	12.2	3.2	10.3 A	4.7 A
2.8	280	40.6	11.2	3	11.2 A	5.1 A
Fuse required					15 A	8 A

Installation and maintenance

Installation

Locate the pump in a dry location.

If the pump is mounted vertically, the motor shall face up.

Mark screw positions and drill pilot holes (see drilling template page 45).

Mount the pump using stainless steel screws taking care not to over compress the vibration dampening rubber feet.

Reinforced, high pressure flexible tubing is recommended.

If rigid pipe is used, a length (225 mm/9 inches minimum) of flexible tubing shall be installed between the pump and the rigid pipe. This will address noise and/or damage caused by vibration transmitted to rigid pipe.

Use stainless steel hose clamps to secure tubing to quick disconnect fittings and other hose bars in the system.

A strainer must be installed in line before the pump intake, to prevent debris from entering pump and inter-firing with proper functioning of valves.

Electrical installation

The pump must be installed according to ISO 10133 (Small craft – Electrical system – Extra low voltage DC installation for continuous current). Note: The fuse must be ignition protected.

The motor is equipped with built in thermal protection to prevent the motor from overheating. The protection is automatically restored when the motor is cooled.

If the pump is connected with separate earth lead, this should be yellow/green and connected to the motor base.

See the wiring table (next page) for correct installation. Negative wire must be black.

Choose wire size in accordance with total wire length (see table next page).

The wire connections must be sealed with a marine sealant.

Note: Before installation with electrical control systems, check that equipment to be used is of sufficient rated capacity to accept amperage draw of motor. Low voltage will cause motor to overheat.

Maintenance

The system shall be periodically sanitized using the following procedure:

1. Fill the tank with a solution of household bleach and potable water – 1 ml (.03 oz.) bleach/1 l (32 oz.) water.
2. Open all faucets and run until water flowing smells of bleach.
3. Close all faucets.
4. Drain solution from tank.

5. Refill tank with potable water.
6. Open all faucets and run until bleach has been purged.

Wiring table

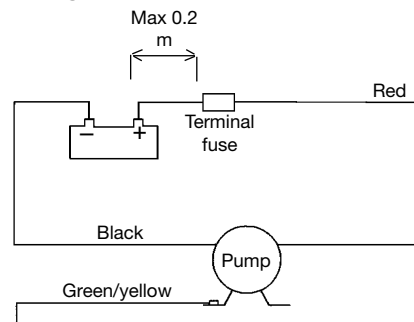

Other electrical devices, eg switch, circuit breaker, must be installed between the pump and the positive (+) lead on the battery (on the red wire).

Wiring dimensions

(based on 3% voltage drop)

WPS 3.4

Wire size		Max wire length* in m	
		12 V	24 V
2.5 mm ²	# 14 AWG	7.7	34.3
4 mm ²	# 12 AWG	12.3	
6 mm ²	# 10 AWG	18.5	
10 mm ²	# 6 AWG	30.8	

WPS 5.0

Wire size		Max wire length* in m	
		12 V	24 V
2.5 mm ²	# 14 AWG	5.2	23
4 mm ²	# 12 AWG	8.4	
6 mm ²	# 10 AWG	12.6	
10 mm ²	# 6 AWG	21	
16 mm ²	# 4 AWG	33.6	

* The wire length is the total distance from the battery to the pump and back to the battery. It is recommended to use a relay with a light wire from main cable to switch to shorten the main leaders.

Start-up procedure

After pump installation, the system can be started by using the following procedure:

- Fill water tank
- Open one tap
- Turn on pump
- Close tap once water begins flowing
- Open each additional tap until all air has been purged from system
- Pump will shut off after taps are closed and pressure builds to the set-point of the pressure switch

Self-priming

Pump is self-priming up to 2 m/6 ft. for WPS 3.4 and 2.5 m/8.2 ft. for WPS 5.0. Intake lines must be air-tight to ensure self-priming.

Dry running

Pump will not be damaged by shorter period of dry running. It will, however, unnecessary reduce your battery power.



Caution

Do not use pump for any other liquids than fresh-water and sea-water.

Temperature

Max liquid temperature: +50°C/+120°F
Max ambient temperature: +60°C/+140°F

Winterizing

If water is not drained from the system during freezing temperatures, damage is likely to be sustained in the plumbing and in the pump. To prevent damage follow the instructions beneath:

1. Drain water storage tank.
2. Open all taps.
3. Run pump until remaining water is expelled.
4. Disconnect inlet and outlet tubes.

5. Run pump briefly to confirm that water has been expelled.
6. Taps shall remain open and pump fittings shall remain disconnected until temperatures are above freezing

Never start a frozen pump. Even if it is drained it might contain a small amount of frozen water that locks the rotor.

Service instructions (see page 42-43)

Change of Switch (pos A)

1. Remove the screws (28) and then remove the complete switch including diaphragm (19).
2. Remove the cables (30 and 31) from the motor cable and power source.
3. Take the new switch and attach the cables to motor and power source.
4. Locate the new diaphragm (19) and then the new complete switch.

Change of Diaphragm kit (pos B)

1. Remove the screws (18) with a Torx #20 tool (a standard Phillips type screw #20 tool). (Pos 18 screws should be fitted to the through holes which can be seen on the backside of the motor end bell).
2. Separate the pump assembly from motor.
3. Remove the screws (17) with a Torx #20 tool (a standard Phillips type screw #20 tool).
4. Hold the black pumpbody (14) towards the ground. Carefully remove the diaphragm kit (B) from pump body (14). Ensuring that pos 10-14 still remains together with pump body (14).
5. Locate the diaphragm kit into pump body (14) incl pos 10-14 and mount the five short screws (17) into the threaded holes in the motor flange.

6. Mount the complete pumphead kit onto the motor coupling flange taking notice to fit the slot in cam (5) in right position against motor shaft and the three slots on motor end bell.
7. Assemble the remaining long screws (18) which will hold the motor/pump unit together. (pos 18 screws should be fitted to the through holes that can be seen on the backside of the motor end bell).

Change of complete Pump kit (pos C)

1. Remove the screws (28) and then remove complete switch including diaphragm (19).
2. Remove the cables pos (30 and 31) from the motor cable and power source.
3. Remove the screws (18) with a Torx #20 tool (a standard Phillips type screw #20 tool). (pos 18 screws has a through hole on the backside of the motor end bell).
4. Separate the pump assembly from the motor.
5. Mount the complete pumphead kit onto the motor coupling flange taking notice to fit the slot in cam (5) in right position against motor shaft and the three slots on the motor end bell.
6. Assemble the long screws (18) which will hold the motor/pump unit together. (pos 18 screws should be fitted to the through holes that can be seen on the backside of the motor end bell).
7. Locate the diaphragm (19) and then the complete switch.

Accessories

(See page 44)

Trouble-shooting chart

<i>Symptom</i>	<i>Cause</i>	<i>Remedy</i>
1. Pump does not run.	1.1 Tripped thermal protector or blown fuse.	1.1.1 Check fuse. If motor is overheated let it cool down prior to restart.
	1.2 Faulty wire connection or power source.	1.1.2 Check battery/power supply, main switch and wiring.
	1.3 Pressure switch malfunctioning.	1.1.3 Change pressure switch.
	1.4 Motor malfunctioning.	1.1.4 Change pump.
	1.5 Pump/motor frozen.	1.1.5 Thaw pump and system and check for damage. The pump/motor is liable to damage when a frozen pump is started
2. Pump does not prime.	2.1 Water tank empty.	2.1.1 Fill up tank.
	2.2 Debris under valves.	2.1.2 Carefully flush pump with tap water at nominal pump flow. Note! Flush in nominal flow direction.
	2.3 Perforated diaphragm.	2.1.3 Replace diaphragm kit.
	2.4 Leak on inlet side of pump.	2.1.4 Check tightness of hose connections at pump, filter and tank.
	2.5 Inlet or outlet plumbing restricted.	2.1.5 Check plumbing.
3. Pump cycles on and off rapidly while water is demanded.	3.1 Restriction on outlet side of pump/too high pressure.	3.1.1 Outlet hose too small, must be of same diameter as pump connection.
4. Pump cycles on and off rapidly while water is not demanded.	4.1 Leak on outlet side of pump.	4.1.1 Check tightness of hose connections, check hose for possible damage.
5. Pump will not stop running when water is not demanded.	5.1 Leak on inlet side of pump.	5.1.1 Check tightness of hose connections, check hose for possible damage.
	5.2 Leak on outlet side of pump.	5.1.2 Check tightness of hose connections, check hose for possible damage.
	5.3 Perforated diaphragm.	5.1.3 Replace diaphragm kit.
	5.4 Water tank empty	5.1.4 Fill up tank.
	5.5 Pressure switch malfunctioning.	5.1.5 Change pressure switch.
	5.6 Low voltage to pump.	5.1.6 Change battery/power supply.
6. Low flow/pressure.	6.1 Leak on inlet side of pump.	6.1.1 Check tightness of hose connections, check hose for possible damage.
	6.2 Leak on outlet side of pump.	6.1.2 Check tightness of hose connections, check hose for possible damage.
	6.3 Perforated diaphragm.	6.1.3 Replace diaphragm kit.
	6.4 Motor malfunction.	6.1.4 Change pump.
	6.5 Debris under valves.	6.1.5 Carefully flush pump with tap water at nominal pump flow. Note! Flush in nominal flow direction.
7. Pump is excessively noisy.	7.1 Pump is plumbed directly to rigid tubing.	7.1.1 Install flexible tubing according to installation recommendation, see page 9.
	7.2 Pump head loose on motor.	7.1.2 Tighten screws.
	7.3 Pump mounting is loose.	7.1.3 Tighten screws.
	7.4 Pump mounting is too rigid.	7.1.4 Use flexible tubing and make sure the dampening rubber feet are used.
	7.5 Defective motor.	7.1.5 Change pump.

Dimensioner och vikter
Dimensions and weights
Abmessungen und Gewichte

Dimensions et poids
Dimensiones y pesos
Dimensioni e peso

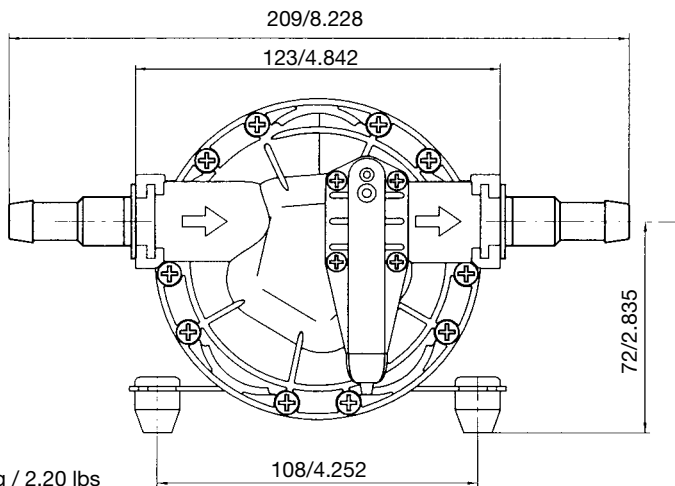
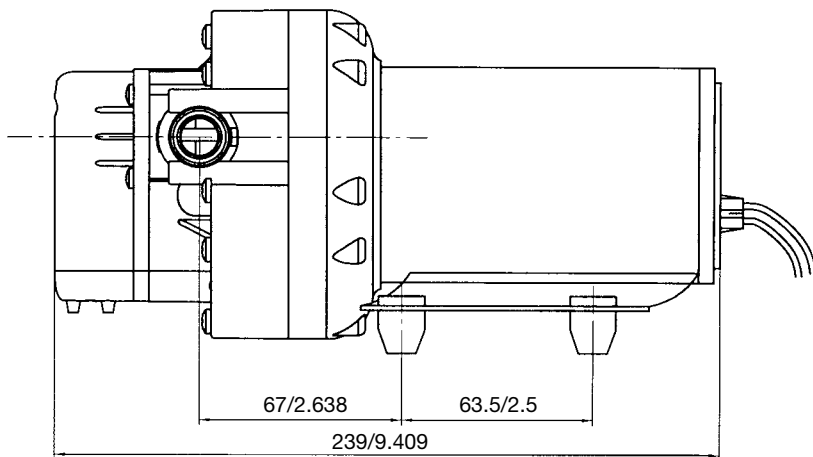

Vikt 2 kg
Weight 2 kg / 2.20 lbs
Gewicht 2 kg
Poids 2 kg
Peso 2 kg

Dim. mm/inches

Reservdelista

Parts list

Teilliste

Liste des pièces

Lista de piezas

Elenco delle parti

Artikkel Nr Part No Artikel Nr Part No Pieza No. Art. No	Pump typ Pump type Pumpe typ Modèle Tipo Tipo	A	B	C	15 a	15 b	2	16	
		A Brytare kpl Switch cpl Schalter Kompl. Contact complet Interruptor compl. Pressostato compl.		B Membranstat Diaphragm kit Membransatz Kit de diaphragme Juego de membrana Kit del diaframma		C Pumphaus kpl Pump head kit Pumpensatz Cors de pompe complet Juego de cabezal de bomba Kit della testa della pompa		15 a Anslutningsstat x 2 1/2" hose/ 3/8" BSP Fittings x 2 1/2" hose/ 3/8" NPT Pumpensatz Anschlüsse x 2 1/2" hose/ 3/8" BSP Kit de raccordement x 2 1/2" hose/ 3/8" BSP Conexiones x 2 1/2" hose/ 3/8" BSP Raccordi x 2 1/2" hose/ 3/8" BSP	16 Läsling Fitting Retainer Sicherungsring Clips Retén Anello di fermo
		15 b Anslutningsstat x 2 3/4" hose/ 1/2" BSP Fittings x 2 3/4" hose/ 1/2" BSP Anschlüsse x 2 3/4" hose/ 1/2" BSP Kit de raccordement x 2 3/4" hose/ 1/2" BSP Conexiones x 2 3/4" hose/ 1/2" BSP Raccordi x 2 3/4" hose/ 1/2" BSP		2 Gummifoot x 4 Rubber foot x 4 Gummifuß x 4 Pied en caoutchouc x 4 Conexiões de goma x 4 Piede di gomma x 4					
10-13250-01/03	WPS 3.4-12V BSP	09-46781-01	09-46779-01	09-46782-01	09-46783	09-46784	09-46780	09-46956	
10-13250-02/04	WPS 3.4-24V BSP	09-46781-01	09-46779-01	09-46782-01	09-46783	09-46784	09-46780	09-46956	
10-13250-05/07	WPS 5.0-12V BSP	09-46781-01	09-46779-02	09-46782-02	09-46783	09-46784	09-46780	09-46956	
10-13250-06/08	WPS 5.0-24V BSP	09-46781-01	09-46779-02	09-46782-02	09-46783	09-46784	09-46780	09-46956	
10-13250-09/11	WPS 3.4-12V BSP	09-46781-03	09-46779-01	09-46782-01	09-46783	09-46784	09-46780	09-46956	
10-13250-10/12	WPS 3.4-24V BSP	09-46781-03	09-46779-01	09-46782-01	09-46783	09-46784	09-46780	09-46956	
10-13250-17/19	WPS 3.4-12V BSP	09-46781-04	09-46779-01	09-46782-01	09-46783	09-46784	09-46780	09-46956	
10-13250-18/20	WPS 3.4-24V BSP	09-46781-04	09-46779-01	09-46782-01	09-46783	09-46784	09-46780	09-46956	
10-13250-13/15	WPS 5.0-12V BSP	09-46781-03	09-46779-02	09-46782-02	09-46783	09-46784	09-46780	09-46956	
10-13250-14/16	WPS 5.0-24V BSP	09-46781-03	09-46779-02	09-46782-02	09-46783	09-46784	09-46780	09-46956	
10-13250-21/23	WPS 5.0-12V BSP	09-46781-04	09-46779-02	09-46782-02	09-46783	09-46784	09-46780	09-46956	
10-13250-22/24	WPS 5.0-24V BSP	09-46781-04	09-46779-02	09-46782-02	09-46783	09-46784	09-46780	09-46956	
10-13250-101/103	WPS 3.4-12V NPT	09-46781-01	09-46779-01	09-46782-01	09-46957	09-46958	09-46780	09-46956	
10-13250-102/104	WPS 3.4-24V NPT	09-46781-01	09-46779-01	09-46782-01	09-46957	09-46958	09-46780	09-46956	
10-13250-105/107	WPS 5.0-12V NPT	09-46781-01	09-46779-02	09-46782-02	09-46957	09-46958	09-46780	09-46956	
10-13250-106/108	WPS 5.0-24V NPT	09-46781-01	09-46779-02	09-46782-02	09-46957	09-46958	09-46780	09-46956	

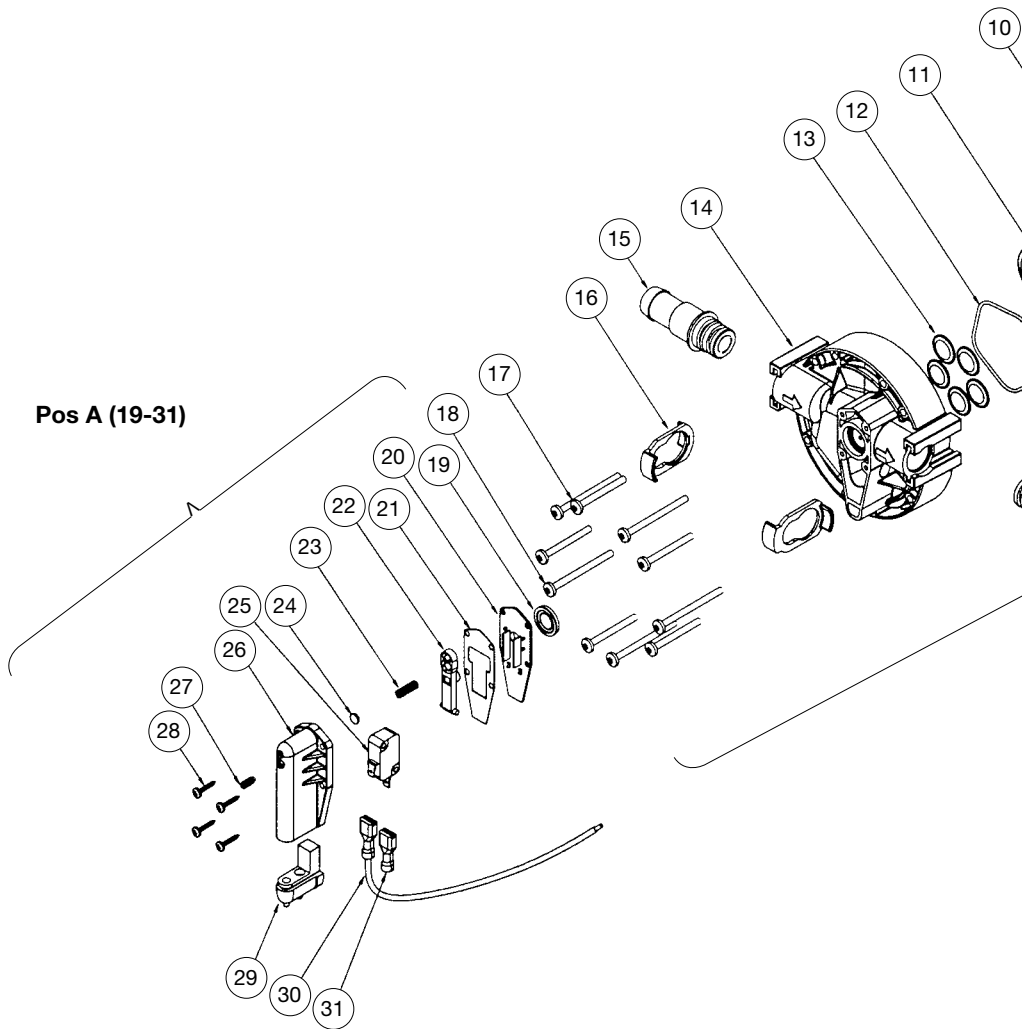

Pos B (4-9)

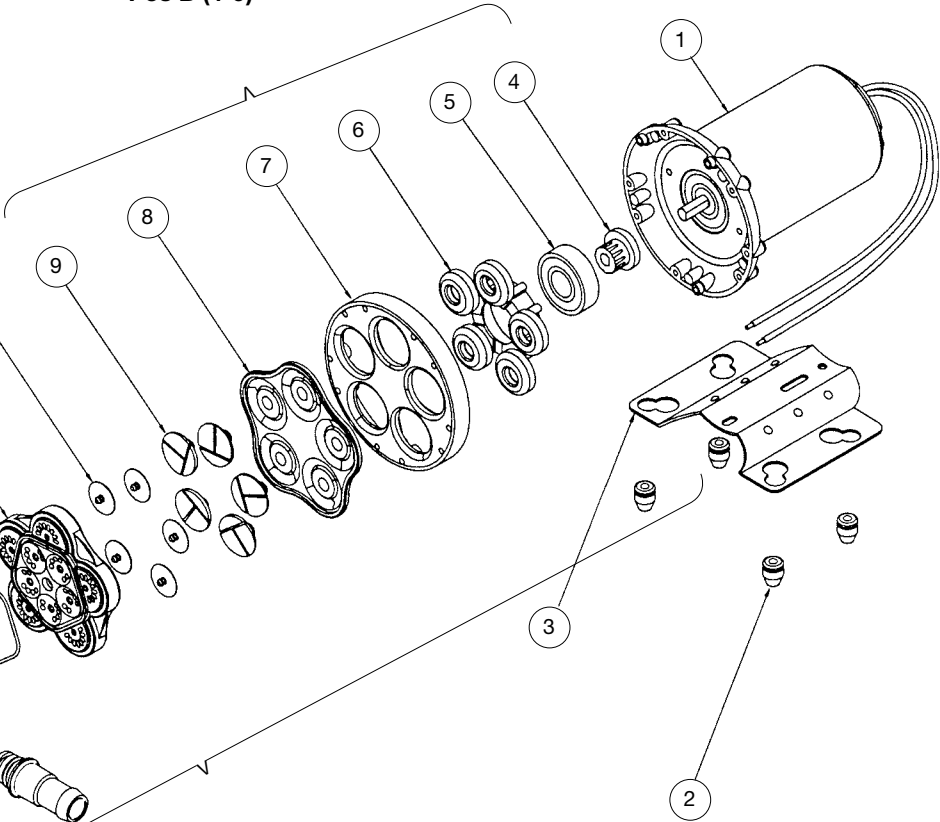

Pos C (4-18 except 15)

Tillbehör
Accessories
Zubehör

Accessoires
Accesorios
Accessori

PUMProtector™ Universal Strainer

Part. No	Mesh	KlickTite™ Connector
09-24652-01	40	2x 1/2" barb / 3/8" BSP
		2x 3/4" barb / 1/2" BSP
09-24652-02	40	2x 1/2" barb / 3/8" NPT
		2x 3/4" barb / 1/2" NPT
09-24652-03	20	2x 1/2" barb / 3/8" BSP
		2x 3/4" barb / 1/2" BSP
09-24652-04	20	2x 1/2" barb / 3/8" NPT
		2x 3/4" barb / 1/2" NPT

PUMProtector™ Inlet Strainer

Part. No	Mesh	KlickTite™ Connector
09-24653-01	40	Built-in KlickTite™ 1x 1/2" barb / 3/8" BSP 1x 3/4" barb / 1/2" BSP
09-24653-02	40	Built-in KlickTite™ 1x 1/2" barb / 3/8" NPT 1x 3/4" barb / 1/2" NPT
09-24653-03	40	Built-in KlickTite™ Bulk pack w/o connectors

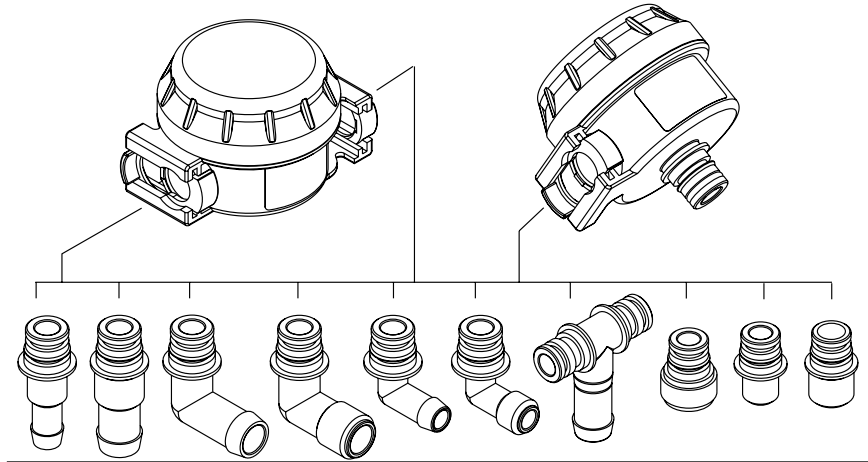

KlickTite™ port connectors available

Part. No.	Connector
09-46783	2 x 1/2" barb and 3/8" BSP
09-46784	2 x 3/4" barb and 1/2" BSP
09-46939	2 x 90°, 3/4" barb
09-47087	2 x 90°, 1/2" BSP
09-46938	2 x 90°, 1/2" barb
09-47026	2 x 90°, 3/8" BSP
09-46957	2 x 1/2" barb and 3/8" NPT

KlickTite™ port connectors available

Part. No.	Connector
09-46958	2 x 3/4" barb and 1/2" NPT
09-47088	2 x 90°, 1/2" NPT
09-47089	2 x 90°, 3/8" NPT
09-47092	1 x T-connection, 3/4" barb
09-47094	2 x Garden hose adapter
09-47096	2 x 3/8" BSP
09-47098	2 x 1/2" BSP

**Filter,
 Inline-strainer,
 Inline-Sieb,
 Crépine de conduite d'arrivée,
 Alcachofa de aspiración en línea,
 Filtro del tubo d'entrada**

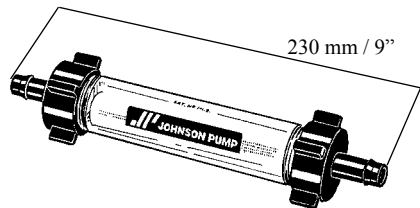

Hålschema 1:1

Hole layout 1:1

Lochsablonen 1:1

Schéma de perçage 1:1

Croquis agujeros 1:1

Schema per l'esecuzione dei fori 1:1

