

16S SERIES

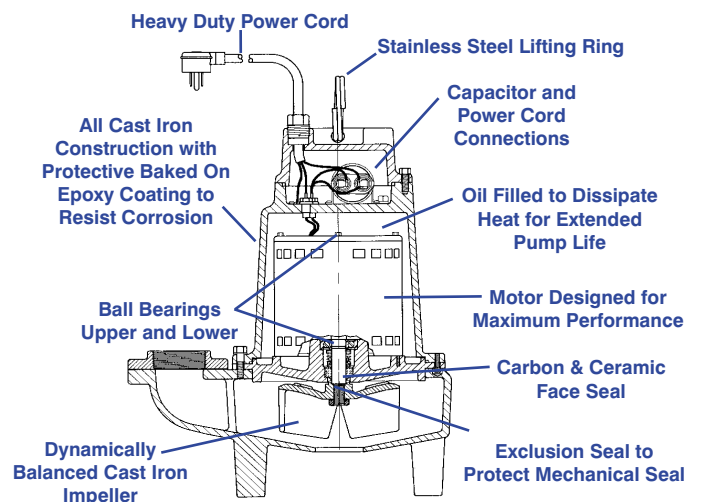

Features

- Handles liquids and solid waste materials up to 2" diameter.
- Cast iron pump housing with protective epoxy coating for corrosion resistance
- Oil-filled motor housing for lifetime lubrication and rapid heat dissipation
- Stainless steel screws, bolts and lifting ring
- Mechanical seals (stainless steel spring, nitrile parts, carbon and ceramic faces) for long life and reliability
- Secondary exclusion seal to help protect mechanical seal
- 1 HP ball bearing motor
- Thermal overload protection
- Permanent split capacitor design on single phase models
- Capacitor & power cord isolated from oil-filled motor housing for ease of field maintenance
- Dynamically balanced two-vane non-clogging impeller with pump-out vanes to protect seal



For Residential, Commercial, Industrial and Agricultural use. Pumps feature 3" FNPT discharge with a lift of 35', heavy duty cast iron construction and stainless steel hardware.

Little Giant Pump Co.

16S SERIES SEWAGE EJECTOR PUMP

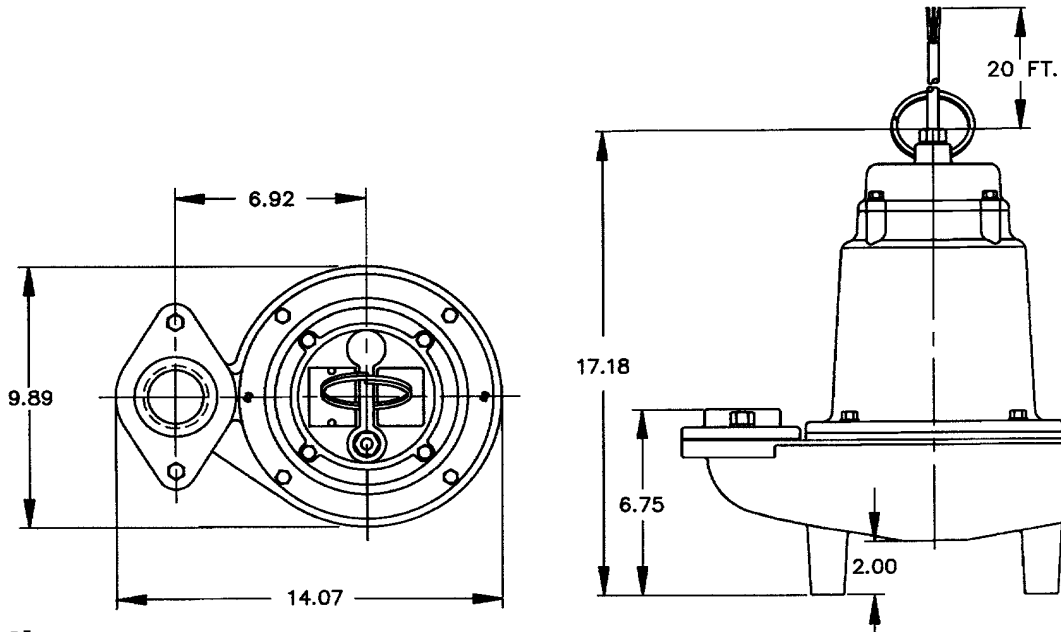

Specifications

MODEL NO.	ITEM NO.	DISCHARGE	SOLIDS SIZE (Dia. In.)	LISTING	HP	VOLTS	PHASE	Hz.	RPM	AMPS/WATTS	SHUT OFF (Ft.)	P.S.I.	PWR CRD* (Ft.)	WEIGHT (Lbs.)
16S-CIM	514620	3" FNPT	2"	UL/CSA	1	230	1	60	1625	11.0/1900	35'	15.1	20'	88
16S-CIM	514630	3" FNPT	2"	UL/CSA	1	230	1	60	1725	11.0/1900	35'	15.1	40'	88
16S-CIM	514625	3" FNPT	2"	UL/CSA	1	200-208	1	60	1650	11.0/2000	35'	15.1	20'	88
16S-CIM	514720	3" FNPT	2"	UL/CSA	1	230	3*	60	1725	6.3/1550	35'	15.1	20'	88
16S-CIM	514730	3" FNPT	2"	UL/CSA	1	460/380	3*	60/50	1725	3.2/1400	35'	15.1	20'	88
16S-CIM	514740	3" FNPT	2"	CSA	1	575	3*	60	1725	2.5/1400	35'	15.1	20'	88
16S-CIM	514750	3" FNPT	2"	UL/CSA	1	200-208	3*	60	1725	6.8 Amps	35'	15.1	20'	88

* 3 Phase Pumps Require Control Panel to Operate

* w/out plug

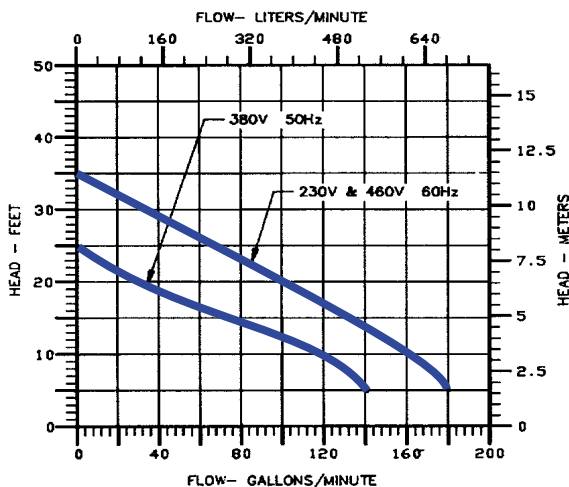

PUMP PERFORMANCE CURVE

Construction

Motor Housing	Epoxy Coated Cast Iron
Impeller Material	Epoxy Coated Cast Iron
Impeller Type	Two Vane, non-clog
Volute	Epoxy Coated Cast Iron
Power Cord	16/3, STW
Mechanical Shaft Seal	Nitrile Parts with Carbon/Ceramic Faces
Fasteners	Stainless Steel
Shaft	Stainless Steel
Bearings	Upper and lower ball bearings



ISO 9001 CERTIFIED

Little Giant Pump Co.

PO Box 12010
Okla. City, OK 73157

Phone: 405.947.2511
Fax: 405.228.1550

www.LittleGiantPump.com

Form No. 994353 - 11/99