

OPERATOR'S MANUAL

CHEMSTEEL R1/ RM1

INCLUDING: OPERATION, INSTALLATION AND MAINTENANCE

RELEASED: 6-10-22
(REV: A)



**READ THIS MANUAL CAREFULLY BEFORE INSTALLING,
OPERATING OR SERVICING THIS EQUIPMENT.**

It is the responsibility of the employer to place this information in the hands of the operator. Keep for future reference.

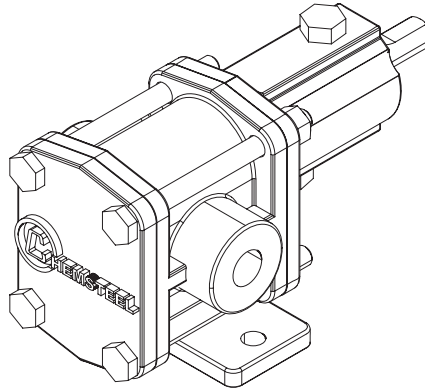

R1 Series

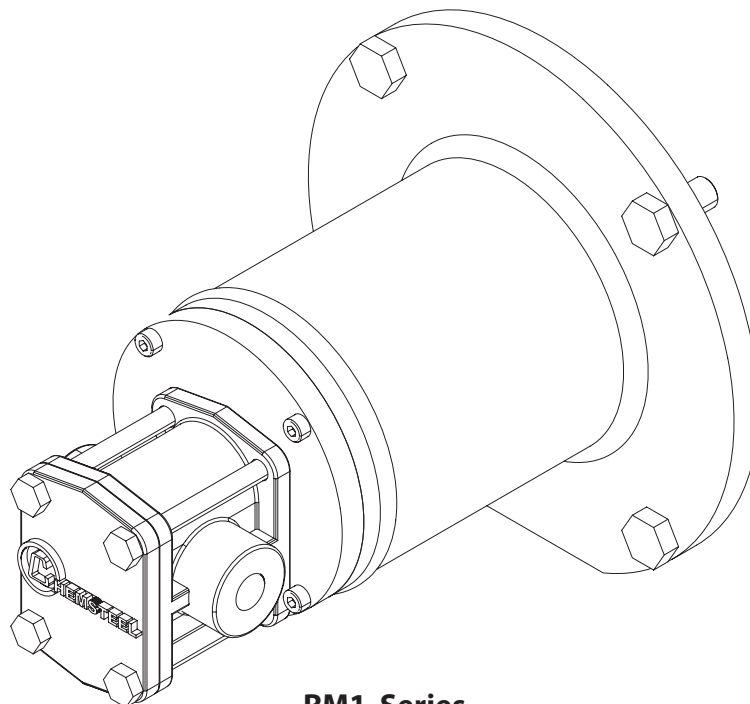

RM1 Series

Figure 1

INGERSOLL RAND COMPANY INC
34800 BENNETT DR, FRASER, MI 48026

1-800-448-1668 • support@oberdorferpumps.com
www.gardnerdenver.com/en-us/oberdorferpumps

© 2022



OBERDORFER



GENERAL DESCRIPTION

Chemsteel R1 / RM1:

Chemsteel pumps are designed to handle common and highly corrosive liquids that must be pumped under pressure. Manufactured to extremely precise tolerance, the Chemsteel pump line prevents system contamination while maintaining the purity and integrity of the liquid being pumped. Its rugged, three-section, o-ring sealed thru-bolt construction provides ease of servicing and parts replacement.

Helical gearing offers noise reduction by as much as 10db, while the tandem pumps double the output flow for a single fluid, or with isolation, handle other fluids in direct ratio to the first. Additionally, Chemsteel pumps offer bi-directional operation for applications requiring reversing flow.

MODEL DESCRIPTION CHART

Model Code Explanation	OB	R1	XX	X	X	X	X	X
Basic Pump Series R1								
Flow Rate								
Code								
02								
03								
04								
06								
Housing and Shaft Material								
Code								
1								
3								
Gear Material Combination								
Code								
1								
2								
3								
4								
5								
6								
7								
8								
9								
A								
B								
C								
D								
E								
F								
H								
Bearing Material								
Code								
C								
P								
J								
Shaft Seal								
Code								
B								
J								
H								
Z								
A								
C								
D								
F								
V								
G								
L								
W								
Additional Options								
Code								
C1 - C7								
T1 - T13								
B								
E								
XX								
M1 - M7								

NOTICE: All possible options are shown in the chart, however, certain combinations may not be recommended. Consult a representative or the factory if you have questions concerning availability.

MODEL CODE EXPLANATION

Example:

OBR10636CCB

Flow Rate Code

Code	Max Flow GPM @ 1725 RPM
02	0.5
03	1
04	1.5
06	2.0

Housing and Shaft Material

Code	Housing Material	Shaft Material
1	316 Stainless Steel	316 Stainless Steel
3	Alloy C	Alloy C

Bearing Material

Code	Material
C	Carbon Graphite Resin
P	PTFE
J	Rulon / Glass filled PTFE

Gear Material Combination

Code	Drive	Idle
1	PPS	PPS
2	316 Stainless Steel	PEEK
3	PEEK	PEEK
4	Alloy C	Alloy C
5	Alloy C	PTFE
6	W88	W88
7	PTFE	PTFE
8	W88	PTFE
9	Alloy C	PEEK
A	Alloy C	PPS
B	316 Stainless Steel	PPS
C	W88	PPS
D	W88	316 Stainless Steel
E	316 Stainless Steel	316 Stainless Steel
F	316 Stainless Steel	PTFE
H	W88	PEEK

Shaft Seal

Code	Style			Material			
				Rotary Head	Stationary Head		
	Deign	Seals	Case	Face	Elastomer	Face	O-Ring
B	Bellows	Single	316 SS	Carbon	FKM	Ceramic	FKM
J	Bellows	Single	316 SS	Silicon Carbide	EPDM	Silicon Carbide	EPDM
H	Bellows	Double	316 SS	PTFE	FKM	Ceramic	FKM
Z	Bellows	Single	316 SS	Silicon Carbide	FKM	Silicon Carbide	FKM
A	Wedge	Single	316 SS	Carbon	PTFE	Ceramic	FFKM
C	Wedge	Single	316 SS	Carbon	PTFE	Silicon Carbide	FFKM
D	Wedge	Single	Alloy C	Carbon	PTFE	Ceramic	FFKM
F	Wedge	Single	Alloy C	Carbon	PTFE	Silicon Carbide	FFKM
V	Wedge	Single	Alloy C	Silicon Carbide	PTFE	Silicon Carbide	FFKM
G	Wedge	Double	316 SS	Carbon	PTFE	Silicon Carbide	FFKM
L	Two Lips Seals		304 SS	FKM Backed By PTFE			
W	Mag-Coupled			Samarium Colbalt			

Additional Options

Code	Option
C1 - C7	Factory installed close coupled adapter
T1 - T13	Non-Metallic Gear • Temperature Trim
B	Bearing Flush Ports
E	BSPT Threads
XX	Specials - Consult Factory
M1 - M7	Factory Installed Close Coupled Adapter - Mag-Coupled

PRESSURE AND TEMPERATURE TRIMS

The selection of the appropriate Chemsteel pump to fit a given application depends upon full knowledge of the application including both system parameters and fluid properties. Follow the guidelines given below when selecting a Chemsteel gear pump.

Chemical Compatibility: Select the basic materials of construction for the pump based upon chemical compatibility. Refer to Chemical Resistance Charts to decide on acceptable materials of construction. Then, consider the fluid's lubricity.

Lubricity: As a general rule, use only metal/plastic, plastic /plastic, or W88/W88 gear combinations for non lubricating fluids, typically viscosities less than 25 centipoise. Drive / Idle gear combinations of 316 / 316 and Alloy-C / Alloy-C must only be used with lubricating fluids to avoid galling.

Pressure: Refer to the following table for limitations on pressure for various constructions. (Not applicable to tandem pumps, consult factory.)

Gears and Bearings

Gear Combination	Maximum Differential Pressure		
	Carbon Bearings	PTFE Bearings	Rulon Bearings
Plastic / Plastic	50 psi (3.4 bar)	50 psi (3.4 bar)	50 psi (3.4 bar)
Metal / Plastic	100 psi (6.9 bar)	50 psi (3.4 bar)	75 psi (6.9 bar)
Metal / Metal	150 psi ** (10.3 bar)	Not Available	100 psi (6.9 bar)

** Mag Drive limited to 110 psi (7.6 bar).

Housing

Housing	Maximum Differential Pressure	Maximum System Pressure
Metal	150 psi (10.3 bar)	300 psi (20.7 bar), R1/ RM1 and S2 / SM2 Series
Metal	150 psi (10.3 bar)	225 psi (15.5 bar), S4 SM4 and S9 / SM9 Series

Temperature, when using plastic gears and/or bearings: Refer to the following table for selection of the appropriate Trim Code when using plastic gears. PTFE or PEEK gears must be trimmed for applications exceeding 110° F (43.3° C). PPS gears (to a maximum temperature of 200° F (93.3° F)) in either a metal housing are thermally stable and do not require trimming.

Trim Code	PTFE / Rulon	Peek
T1	115° to 134° F (46° to 57° C)	200° to 239° F (93° to 115° C)
T2	135° to 154° F (57° to 68° C)	240° to 279° F (116° to 137° C)
T3	155° to 174° F (68° to 79° C)	280° to 319° F (137° to 159° C)
T4	175° to 194° F (79° to 90° C)	320° to 359° F (160° to 182° C)
T5	195° to 215° F (90° to 102° C)	360° to 400° F (182° to 204° C)
T6	216° to 236° F (102° to 113° C)	
T7	237° to 257° F (114° to 125° C)	
T8	258° to 278° F (-51° to 138° C)	
T9	279° to 299° F (126° to 148° C)	
T10	300° to 320° F (149° to 160° C)	
T11	321° to 341° F (161° to 172° C)	
T12	344° to 362° F (173° to 183° C)	
T13	363° to 383° F (184° to 195° C)	

Code	Magnet Material	Temp. Limit
W	Samarium Cobalt	450° F (232° C)

Chemsteel pumps can be applied for temperatures as low as -50° F (-45.5° C) for pumps of metal construction.

SPECIFICATIONS

	R102 / RM102	R103 / RM103	R104 / RM104	R106 / RM106
Maximum flow (gpm) / (lpm) @1750 rpm	0.6 / 2.2	1.5 / 5.6	2 / 7.5	3 / 11.3
Theoretical displacement (CC / Revolution)	1.9	3.8	5.7	7.5
Maximum differential pressure (psig / bar)	110 / 7.9	150 / 10.3	150 / 10.3	150 / 10.3
Maximum system pressure (psig / bar)	300 / 20.7	300 / 20.7	300 / 20.7	300 / 20.7
Maximum speed (RPM)	1800	1800	1800	1800
Maximum fluid temperature	450° F (232.2° C)	450° F (232.2° C)	450° F (232.2° C)	450° F (232.2° C)
Minimum fluid temperature	-50° F (-45.5° C)	-50° F (-45.5° C)	-50° F (-45.5° C)	-50° F (-45.5° C)
Standard port size	1/4" (6.35 mm) FNPT 1/4" (6.35 mm) BSPT	1/4" (6.35 mm) FNPT 1/4" (6.35 mm) BSPT	1/2" (12.7 mm) FNPT 1/2" (12.7 mm) BSPT	1/2" (12.7 mm) FNPT 1/2" (12.7 mm) BSPT
Weight (lbs / kgs)	4 / 1.8	4 / 1.8	4 / 1.8	4 / 1.8

Maximum pressures and temperatures may be limited by Gear / Bearing / Seal selection.

OPERATING AND SAFETY PRECAUTIONS

READ, UNDERSTAND, AND FOLLOW THIS INFORMATION TO AVOID INJURY AND PROPERTY DAMAGE.



⚠ WARNING Be sure hoses and other components can withstand fluid pressures developed by this pump. Check any hoses for damage or wear. Be certain dispensing device is clean and in proper working condition.

⚠ WARNING IMPROPER GROUNDING. Can increase spark and electrical shock risk, resulting in severe injury or death. Ground pump and pumping system.

- The pumping system must be grounded when it is pumping, flushing, recirculating, or spraying flammable materials such as paints, solvents, lacquers, etc. or used in a location where surrounding atmosphere is conducive to spontaneous combustion. Ground the dispensing valve or device, containers, hoses, and any object to which material is being pumped.
- Secure pump, connections, and all contact points to avoid vibration and generation of contact or static spark. Consult local building codes and electrical codes for specific grounding requirements. After grounding, periodically verify continuity of electrical path to ground. Test with an ohmmeter from each component (e.g., hoses, piping, pump, clamps, motor, base plate, etc.) to ground to ensure continuity. Ohmmeter should show 0.1 ohms or less.

⚠ WARNING HAZARDOUS PRESSURE. Can result in serious injury or property damage. Do not service or clean pump while the system is pressurized.

⚠ WARNING HAZARDOUS MATERIALS. Can cause serious injury or property damage. Do not attempt to return a pump to the factory or service center that contains hazardous material. Safe handling practices must comply with local and national laws and safety code requirements. Obtain Material Safety Data Sheets on all materials from the supplier for proper handling instructions.

⚠ CAUTION Check pump seals, elastomers, and all wetted parts to assure compatibility before using commission of the product.

- Verify the chemical compatibility of the pump wetted parts and the substance being pumped, flushed or recirculated. Chemical compatibility may change with temperature and concentration of the chemical(s)

within the substances being pumped, flushed or circulated. For specific fluid compatibility, consult the chemical manufacturer.

⚠ CAUTION Maximum temperatures are based on mechanical stress of seals and elastomers only. Certain chemicals will significantly reduce maximum safe operating temperature. Consult the chemical manufacturer for chemical compatibility and temperature limits.

⚠ CAUTION Be certain all operators of this equipment have been trained for safe working practices, understand it's limitations, and wear safety goggles / equipment when required.

⚠ CAUTION Do not use the pump for the structural support of the piping system. Be certain the system components are properly supported to prevent stress on the pump parts.

⚠ CAUTION Prevent unnecessary damage to the pump. Do not allow pump to operate in a dry run condition or under cavitating conditions for extended periods.

⚠ CAUTION Use only genuine MP Pumps® replacement parts to assure compatible pressure rating and longest service life.

⚠ CAUTION The mechanical seal in the pump must not be operated dry.

⚠ CAUTION If a pump will be idle in freezing weather it should be drained or filled with the proper anti-freeze.

NOTICE Pump should be installed in the position consistent with the manufactures specifications.

NOTICE Re-torque all fasteners before operation. Creep of housing and gasket materials may cause fasteners to loosen. Re-torque all fasteners to insure against fluid leakage.

⚠ WARNING = Hazards or unsafe practices which could result in severe personal injury, death or substantial property damage.

⚠ CAUTION = Hazards or unsafe practices which could result in minor personal injury, product or property damage.

NOTICE = Important installation, operation or maintenance information.

STORAGE PRECAUTIONS

Drain pump, flush with water, and dry before prolonged storage after initial use.

INSTALLATION

Inspection:

Upon receipt of any pump or pump unit, check carefully for possible damage or shortages. Be sure that the shaft has not been bent or damaged. Rotate the pump by hand to be sure it is free and without tight spots. If the pump is to be stored, it should be kept in a dry location.

Mounting Bases:

Pump units should be mounted on either a concrete or metal foundation of sufficient weight and strength to properly support the entire pump unit. It should be located as close to the liquid source as is practical, while allowing for accessibility for normal pump maintenance. The foundation should be made flat and smooth to ensure correct alignment of the pump. Provisions should be made to bolt the unit securely in place.

Do not locate the pump unit in a pit unless provisions have been made for proper drainage and ventilation.

Alignment:

Correct alignment is absolutely essential for satisfactory pump life. Complete pump units are set and aligned at the factory on a flat surface plate and shims are inserted where necessary to provide perfect alignment. However, all baseplates are somewhat elastic and as a result we cannot assume responsibility for mechanical operation unless the shop alignment is reproduced when the unit is secured to its foundation. Since no foundation is perfectly flat or level, it is therefore necessary to shim the baseplate until the pump and motor shafts are level and parallel.

Recommended drive arrangement for pump only is direct motor drive. For belt or pulley drive applications, a pillow block bearing must be used to achieve acceptable pump life. However, it is important to ensure that the pump and motor shafts are parallel and in line. Recheck the alignment after the piping has been connected to the pump.

After the unit has been completely set and piped, check that the pump rotates freely by hand before activating the driver. When pumps only are supplied for field mounting, it is important that the proper alignment between pump and drive is maintained. The baseplate should be secured to a flat surface plate and the driver and pump set so that the shafts are level and parallel.

The use of flexible coupling will not compensate for poor alignment. Parallel alignment can be determined by use of a straight edge across the rim of both coupling halves at four positions, ninety degrees apart. Couplings aligned in this manner should be true to within .005" at any position. Angular alignment can be checked by gauging the coupling gap at several points.

It is particularly important that pumps driven through a flexible coupling be mounted in such a manner as to ensure sufficient gap between the coupling components to allow for any end play in the driver.

TORQUE SPECIFICATIONS

BODY BOLTS - Stainless Steel and Alloy C

Pump Series	Number of bolts	Bolt thread	Bolt / Nut Head	Torque
Series R1 / RM1	4	M6	10 mm hex	45 in-lbs (5.08 Nm)

OTHER MAG DRIVE BOLTS

Bolt thread	Bolt / Nut Head	Torque
M6	3mm socket head	28 in-lbs (3.16 Nm)
M5	4mm socket head	42 in-lbs (4.74 Nm)
M6	10mm hex head or 5mm socket head	45 in-lbs (5.08 Nm)
M8	13mm hex head or 6mm socket head	85 in-lbs (9.6 Nm)

PRESSURE - FLOW - POWER GRAPH

R102:

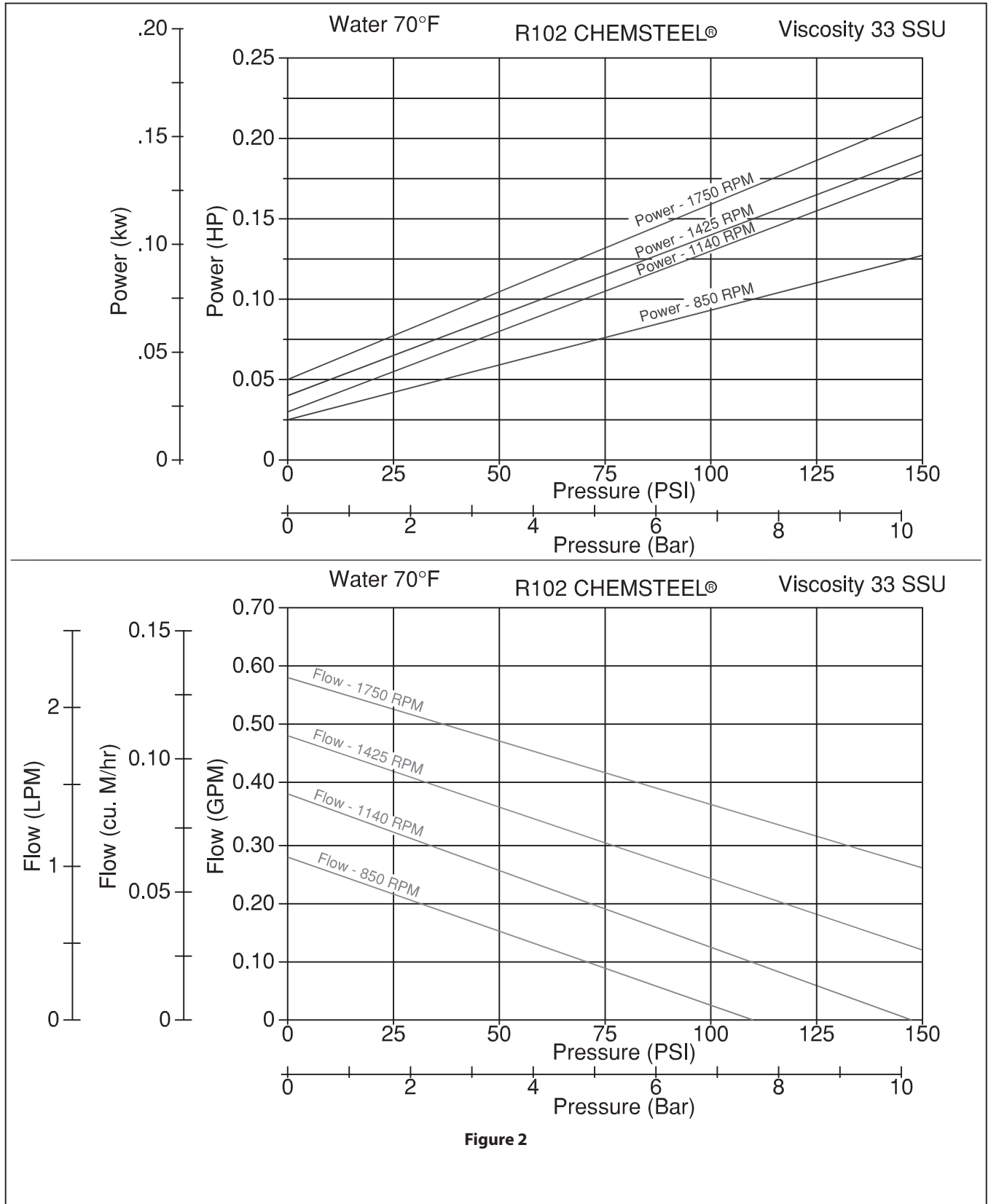

PRESSURE - FLOW - POWER GRAPH

RM102:

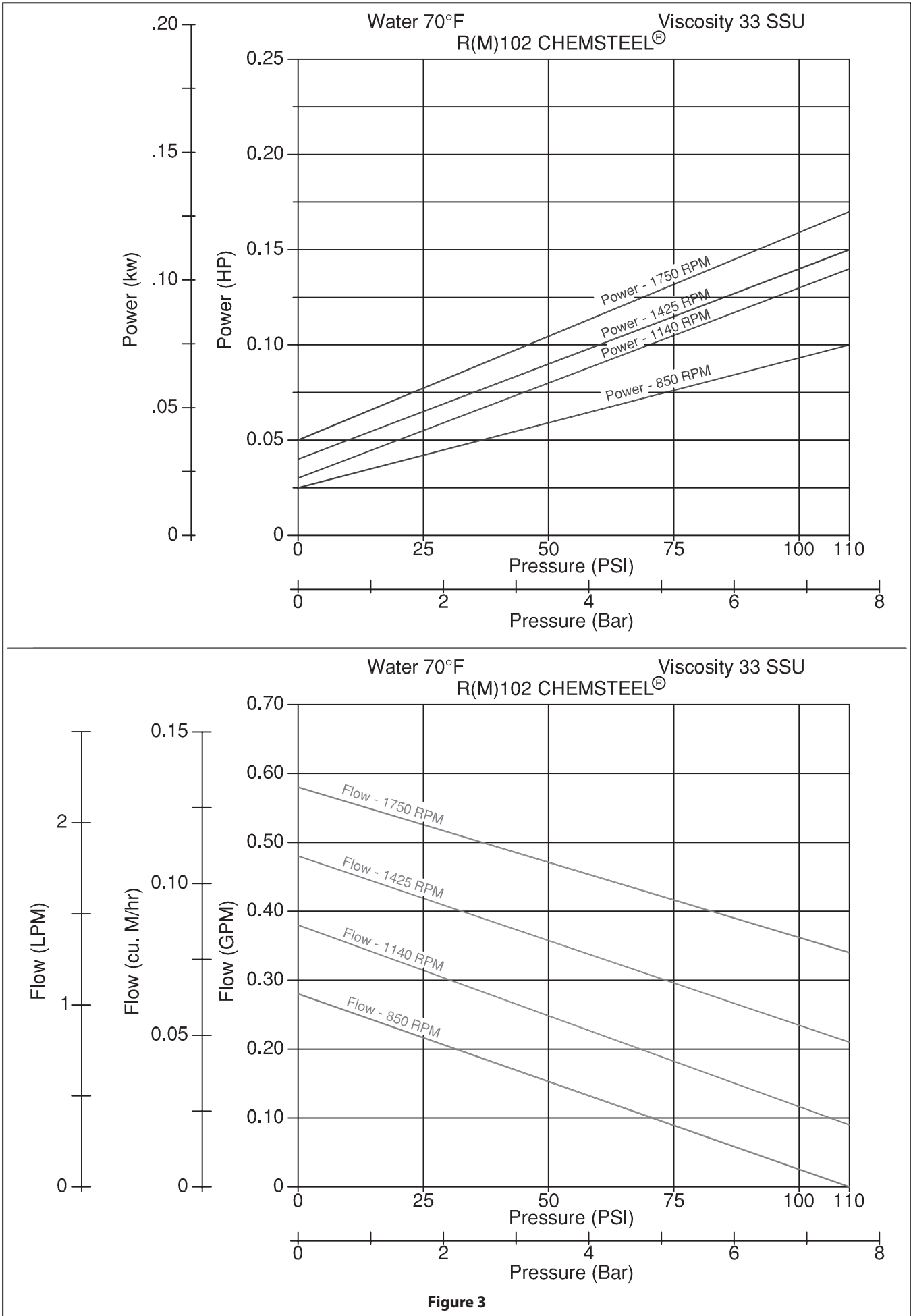

Figure 3

PRESSURE - FLOW - POWER GRAPH

R103:

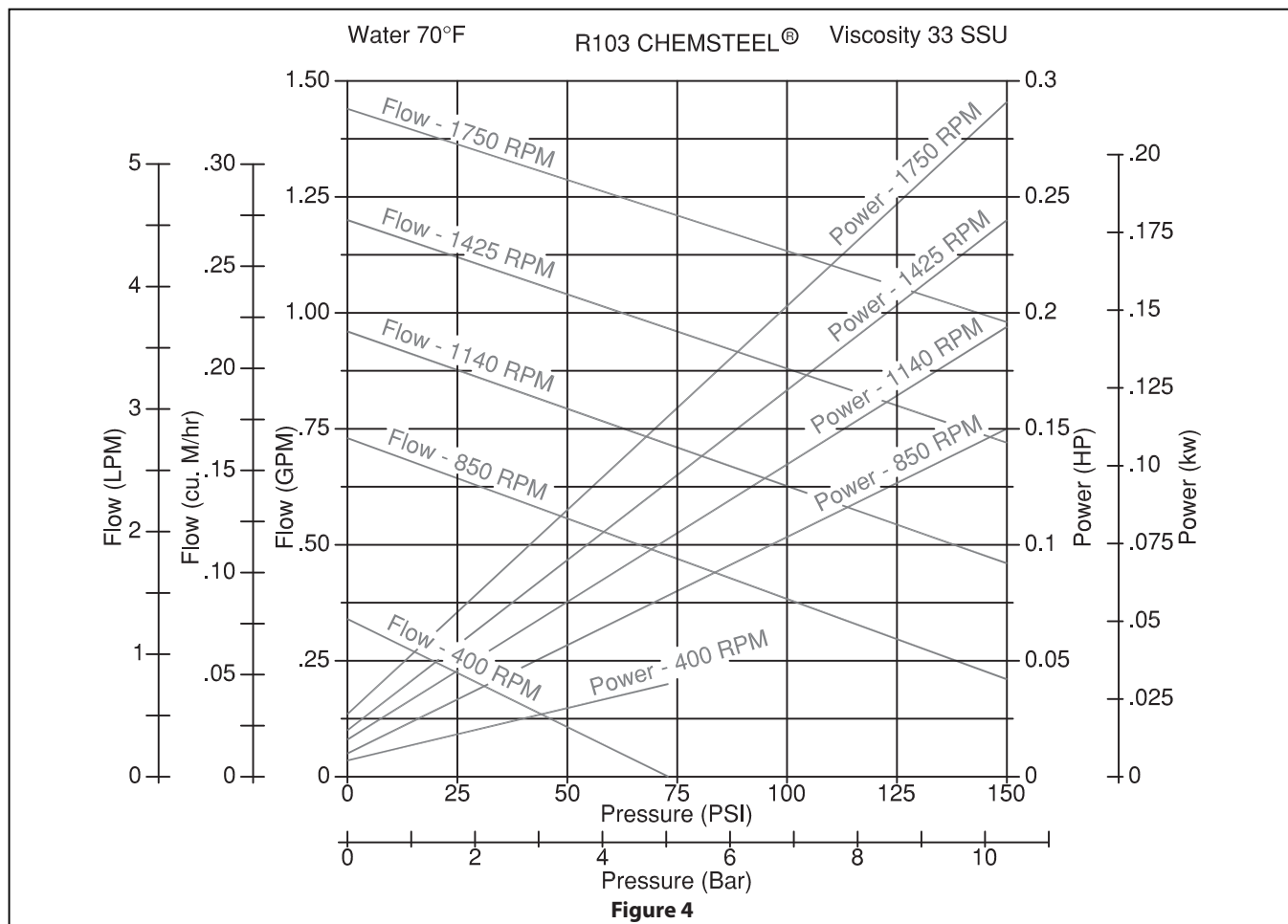

Figure 4

RM103:

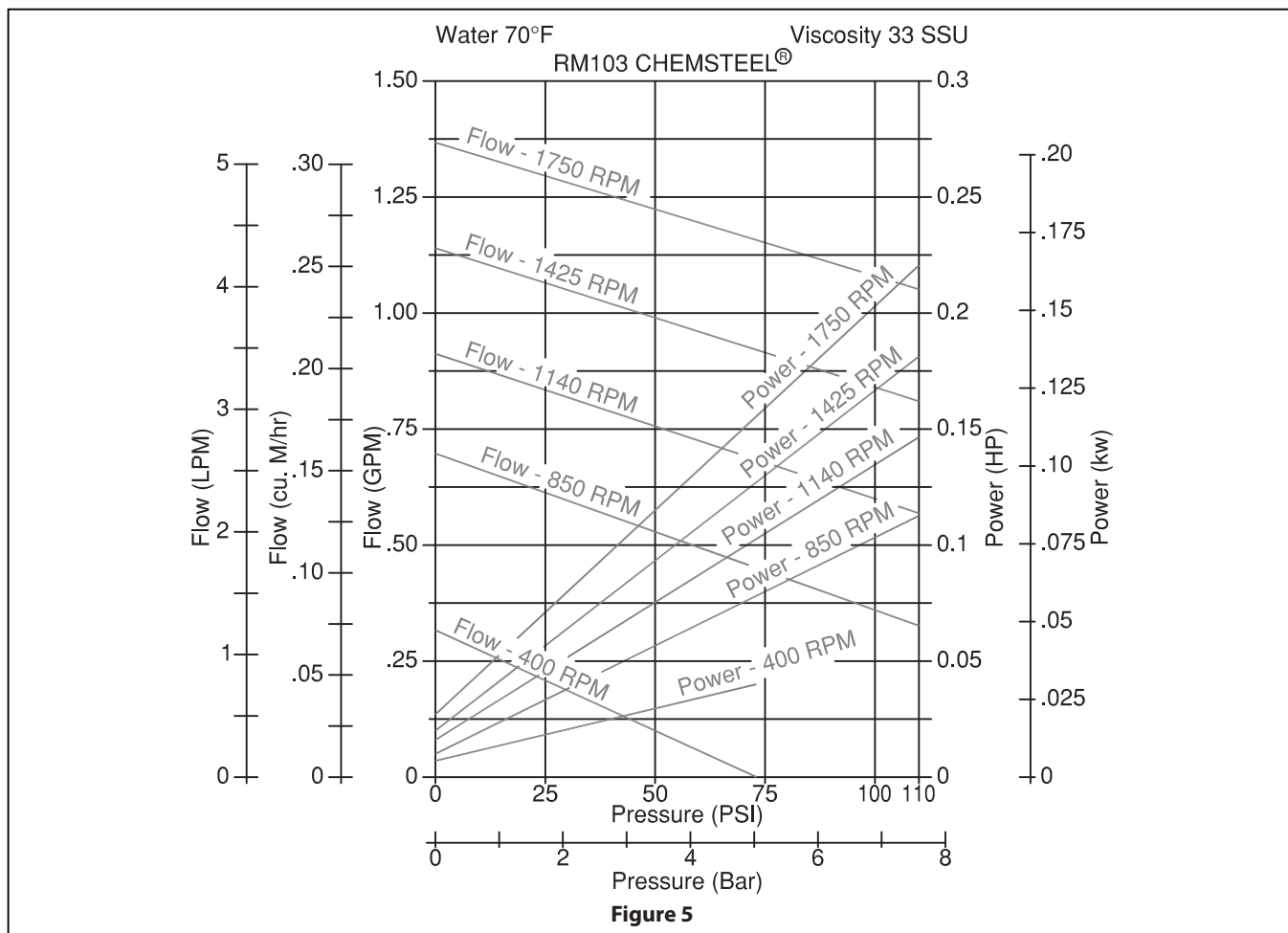
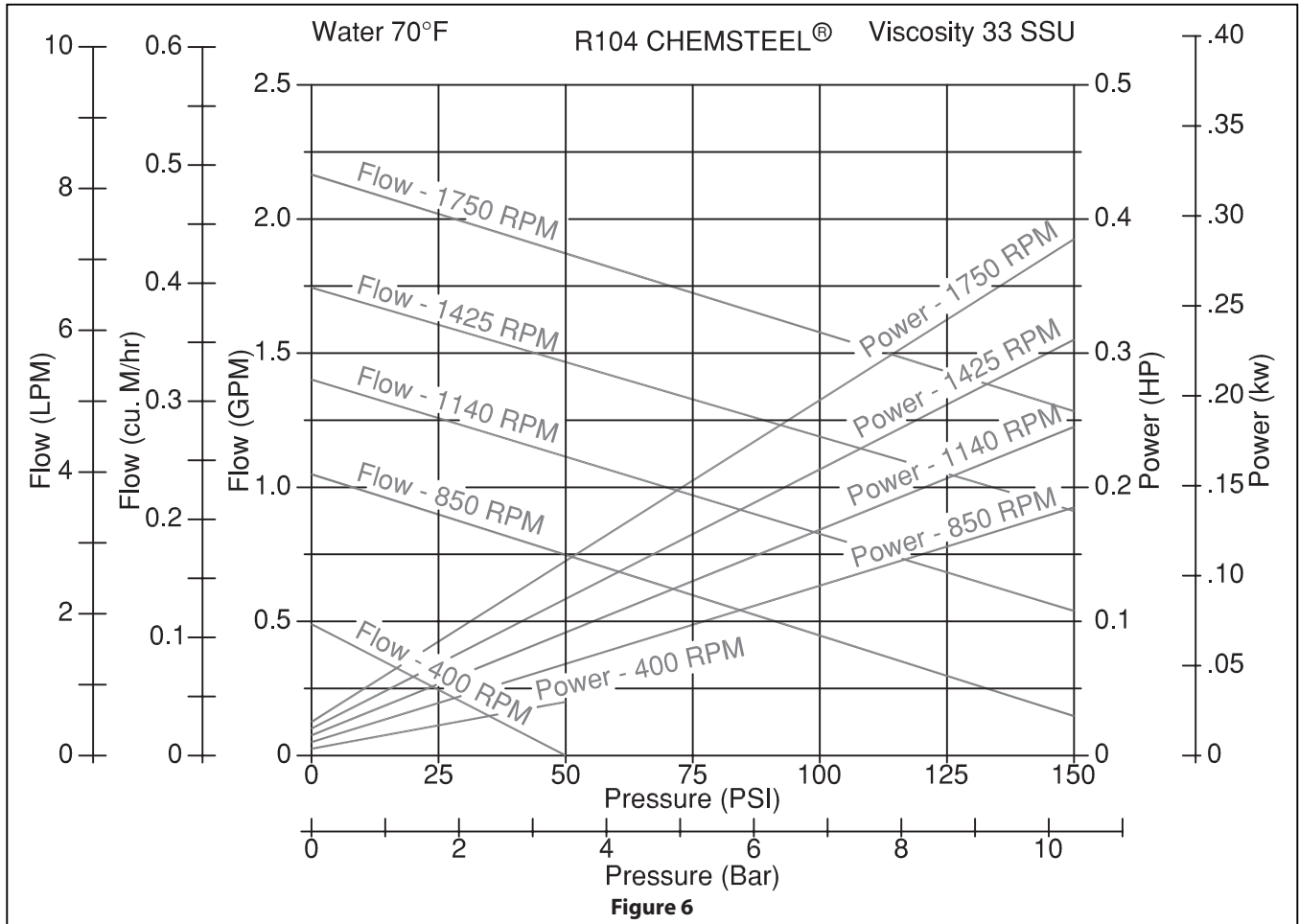

Figure 5

PRESSURE - FLOW - POWER GRAPH

R104:



RM104:

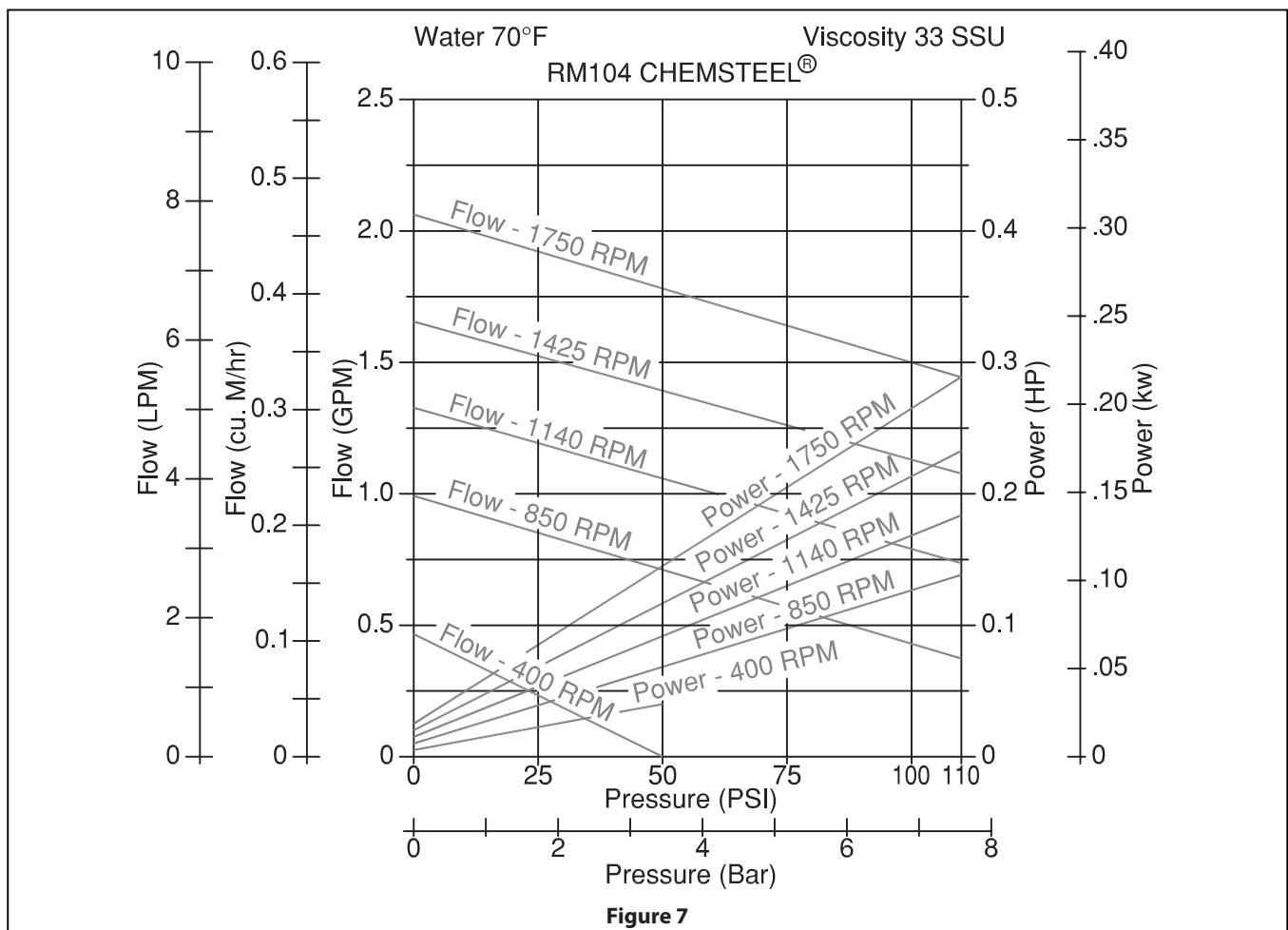

PRESSURE - TEMPERATURE GRAPH

R106:

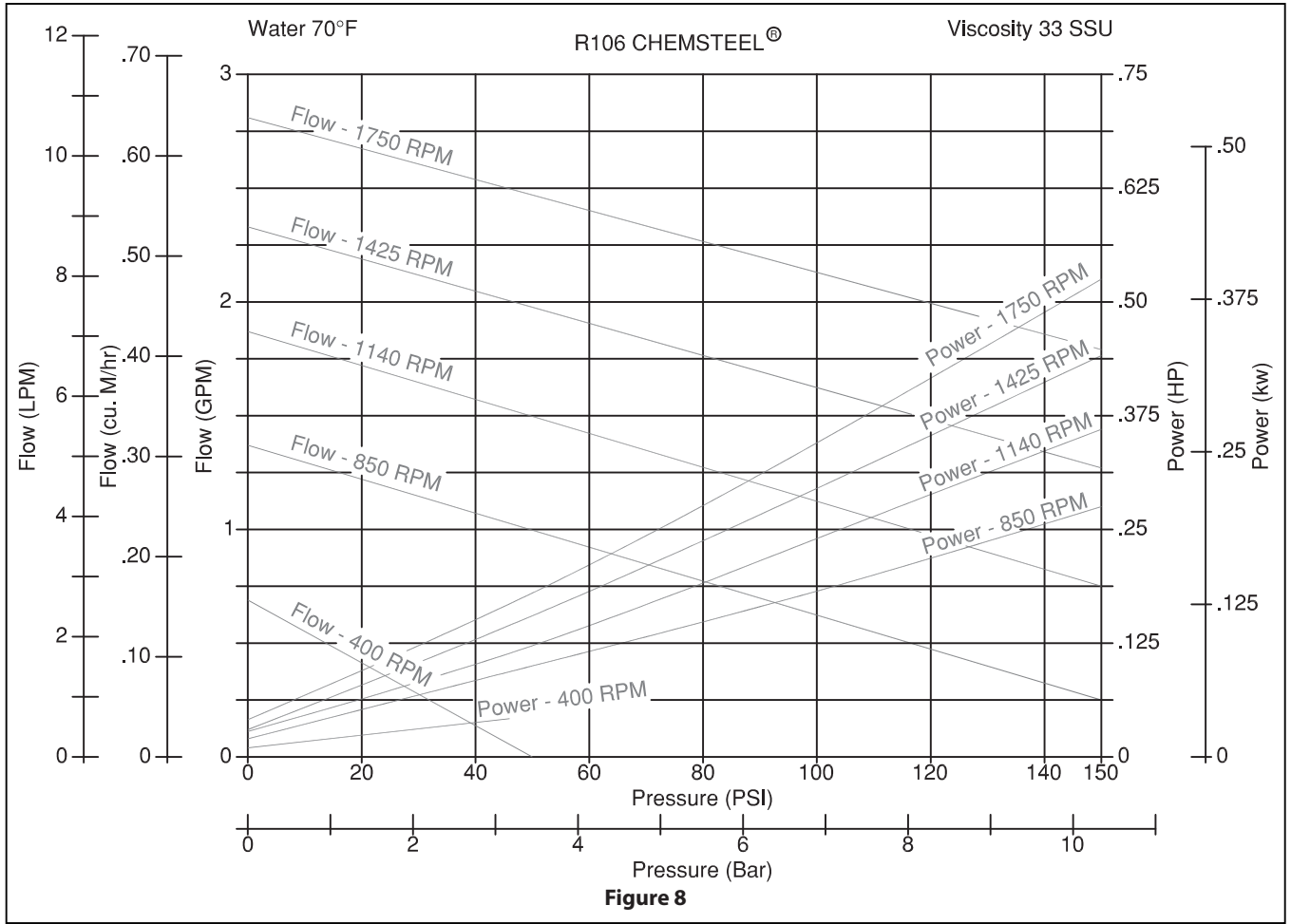

RM106:

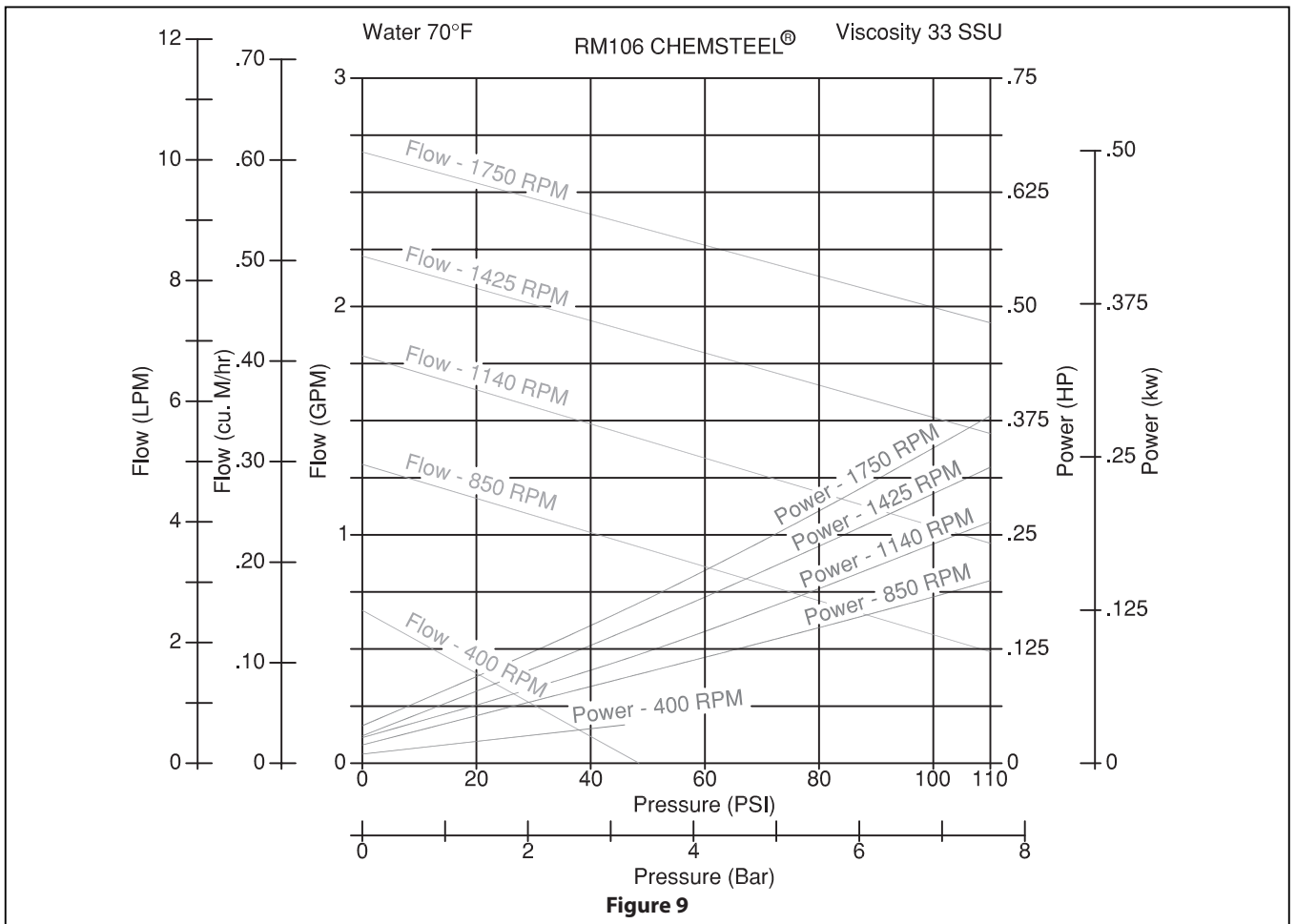

VISCOSITY vs SHAFT SPEED

1. Viscosity				2. Maximum Shaft Speed	3. Multipliers for Horsepower (Multiply X Water Horsepower)					
Liquid @ 70° F (21.1° C)	Centipoise CP @ 0.8 S.G.	Centistokes CS	Viscosity SSU	RPM	2 psi	20 psi	40 psi	60 psi	80 psi	100 psi
Water	1	1	5	1750	1.00	1.00	1.00	1.00	1.00	1.00
	9	11	50	1750	1.00	1.05	1.00	1.00	1.00	1.00
No. 2 Fuel Oil @ 57° F (13.9° C)	17	22	100	1700	1.10	1.10	1.05	1.05	1.00	1.00
	43	54	250	1600	1.20	1.15	1.10	1.10	1.05	1.05
SAE 10 Oil @ 62° F (16.7° C)	86	108	500	1500	1.30	1.25	1.20	1.15	1.10	1.10
	130	162	750	1400	1.45	1.35	1.25	1.20	1.15	1.15
SAE 30 Oil @ 72° F (22.2° C)	173	216	1000	1300	1.60	1.50	1.40	1.30	1.25	1.20
	432	540	2500	1200	1.90	1.75	1.60	1.45	1.35	1.30
SAE 60 Oil @ 70° F (21.1° C)	864	1080	5000	1000	2.20	2.00	1.80	1.60	1.50	1.40
	1296	1620	7500	850	2.60	2.30	2.00	1.80	1.70	1.60
SAE 70 Oil @ 60° F (15.6° C)	1728	2160	10000	600	3.00	2.60	2.20	2.00	1.90	1.80
	4320	5400	25000	500	3.50	3.00	2.70	2.40	2.20	2.00
No. 6 Fuel Oil @ 70° F (21.1° C)	8640	10800	50000	400	4.00	3.60	3.20	2.80	2.50	2.20
	12960	16200	75000	300	4.50	4.10	3.60	3.15	2.75	2.35
No. 6 Fuel Oil @ 60° F (15.6° C)	17280	21600	100000	200	5.00	4.50	4.00	3.50	3.00	2.50

NPSHr vs SHAFT SPEED

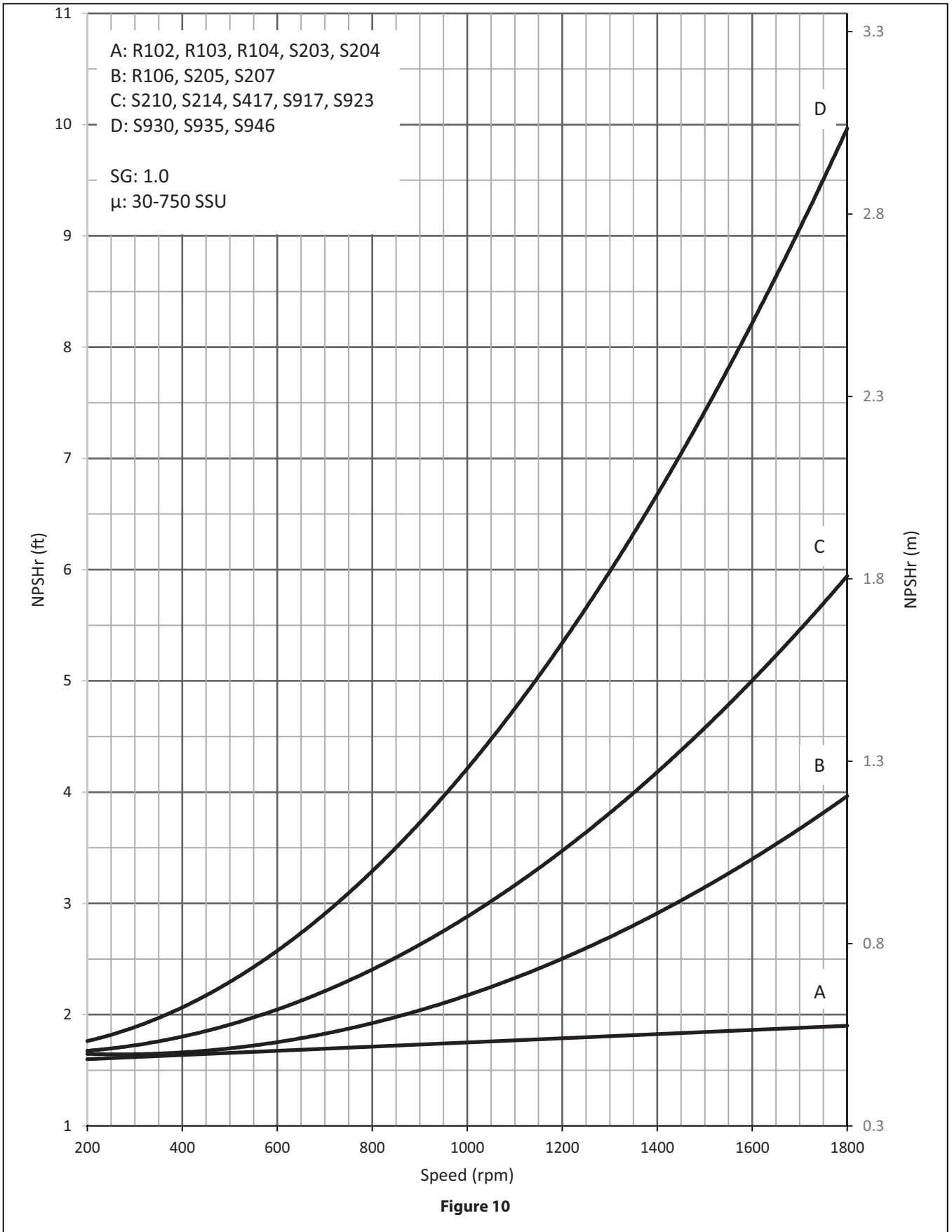

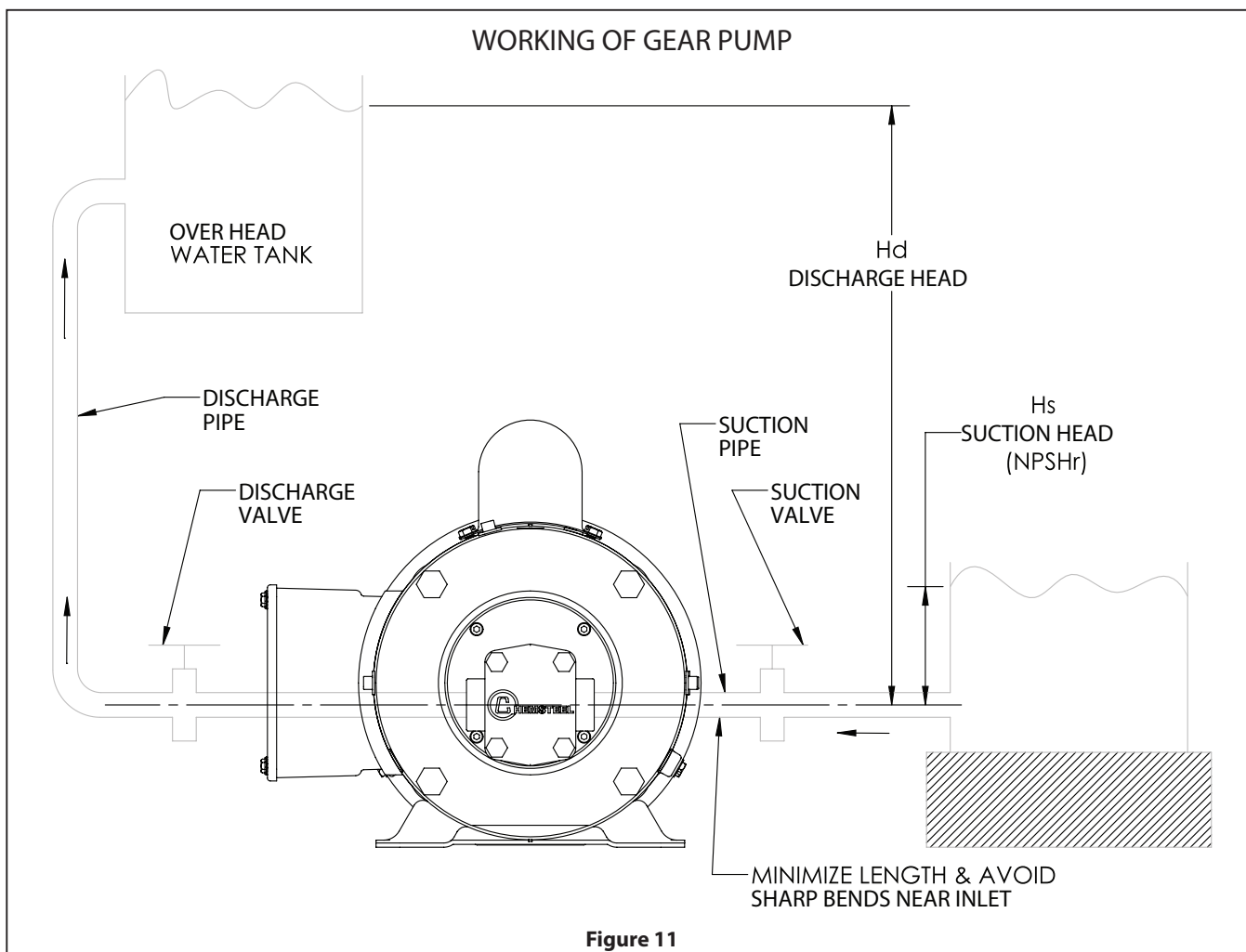

Suction Piping:

Chemical Gear pumps are capable of operating at 17.7 inches mercury suction (20 feet water). If the static lift plus pipe friction losses combine to exceed this figure, pump operation will be erratic or no pumping at all will be realized.

The most desirable pump installations are those with the shortest suction lines. It is therefore important to locate the pump as close to the liquid source as is practical. Suction piping should never be less in diameter than the pump suction opening. When handling thick liquids with appreciable viscosity, the suction pipe should be increased to a greater size than the pump opening.

It is particularly important that the suction line be air tight. Use a good pipe joint compound or tape at all joints. If the suction line is not tight and air is allowed to enter the pump capacity will be noticeably reduced or it may not pump at all. Be sure that the suction line is completely clean and free of any foreign matter. Avoid high spots in piping, which will tend to trap air. It is good practice to install either a foot valve or check valve in the suction line to ensure that the pump will prime quickly when started.

When handling highly volatile chemicals, it is necessary to reduce the suction height to a point where vaporization will not occur. In some instances, a positive suction head will be required.

Suction Strainers:

Gear pumps are designed and fitted with very close internal clearances. The entry of foreign material or abrasives will cause rapid wear or extensive damage to the pump. It is therefore necessary to install a strainer at the pump suction.

Select a strainer of proper size and material with as fine a mesh as is practical, being careful that the pressure drop through the strainer will not add to the suction lift to exceed the suction capability of the pump. Install the strainer as near the pump suction as is practical and in such a manner that it can be easily opened and cleaned. Be sure to arrange a regular inspection on the strainer basket to avoid clogging.

Discharge:

Select pipe of sufficient size to ensure that the resulting friction loss does not add to the discharge head an amount that will exceed the design capability of the pump or motor. It is advisable to install a fitting in the discharge line adjacent to the pump to allow for priming or venting and installation of a pressure gage for both system and pump performance evaluation. To avoid excessive pressure build-up due to a closed or blocked discharge line, or due to an increase in liquid viscosity, it is often necessary to install a relief valve in the pumping system.

Chemical Gear pumps are not available with a relief valve built onto the pump. When required, it is necessary that the relief valve be installed in the discharge piping and piped back to the source of supply. Heat is better dissipated over large surface areas. The relief valve should be set at a pressure of approximately 10 PSI in excess of the designed operating pressure, but not so high as to overload the drive or the pump itself.

Product Contamination

All Chemical Gear pumps are tested using water soluble synthetic coolant. Unless specified, some of this solution remains in the pump during shipment to ensure some lubrication during start-up.

If this solution is detrimental to the system, it will be necessary to dismantle the pump and clean all parts thoroughly. Before starting, be sure to prime the pump with the liquid being pumped or with a good grade of clean, light lubricating oil compatible with the pumped fluid.

OPERATION

Priming:

Before operating the pump, make sure that it is thoroughly primed. If at all possible, use the liquid being pumped or a good grade of clean, light lubricating oil compatible with the pumped fluid. Failure to properly prime the pump could cause immediate damage to the working parts.

Lubrication:

The liquids being pumped lubricate the internal bearings in all Chemical Gear pumps. Outboard pillow block support bearings and motor bearings should be lubricated as covered by the manufacturer's instructions.

Direction of Rotation:

Upper shaft drive is standard and standard direction of rotation is clockwise when facing shaft end of the pump. When rotated in this manner and the pump and/or piping must be installed so that the suction line is connected to the port on the left hand side of the pump. If the right hand port is to be the inlet or suction, the rotation must be counter clockwise when facing the pump from the shaft end.

Chemical Gear pumps are designed to operated in either direction of rotation.

REPAIR

Disassembling Pump:

Repair kits are available for all Chemical Gear pump models. Each repair kit includes replacement o-ring, seal, gears, shafts, bearings, keys, and, retaining rings.

Oberdorfer Chemical Gear pumps are constructed of three sections - a rear cover, a body section, and a front cover. The covers are bolted to the body with socket head cap screws.

Remove the screws and separate pump sections by tapping lightly while forcing sections apart. Pump body and front cover are doweled together. Ease body off of front cover dowel pins by lightly tapping and forcing apart. Lightly tapping on exposed pump drive shaft aids separation of pump section.

- Remove rear bearings.
- Slide out idler gear and shaft assembly and the front idler bearing.
- Slide out the drive gear and shaft assembly and remove o-rings from body.
- For mechanical seal models, the drive gear and shaft assembly also includes a seal retaining ring and seal head and may also include a thrust washer.
- Two set screws may secure the seal head to the drive shaft. If so, loosen both set screws and slide the seal head from the drive shaft.
- Removal of the seal retaining ring ("C" ring) allows sliding off the thrust washer, if included and upper front bearing. Remove the mating seal parts in the front cover chamber (seal wear face and seal seat). They can be pried out by using a hook tool or by pushing a 1/8" diameter drift through the push-out hole or pushed out after removal of the snap ring.
- Metal gears are pinned (non-separable) or keyed to pump shafts. Metal or plastic gears that are driven via a woodruff key are positioned and retained over the key by retaining rings. Gear and shaft components are also normally provided as already assembled assemblies.
- Replace any parts where wear is evident.

Re-Assembling Pump:

Carefully clean all parts and lubricate lightly with the liquid being pumped or with a good grade of clean, light lubricating oil compatible with the pumped fluid. Make sure pump body faces are clean and free of nicks or scratches. If new bearings are used, try in body and on shaft before re-assembling pump.

For mechanical seal models, prepare the front cover for re-assembly by inserting the seal wear face with seal seat into the cover's seal chamber and replacing the snap ring, as required. Use of a quality elastomer lubricant will aid in this step, remove excess.

- Insert o-ring into the groove at each end of the pump body.
- Prepare the drive gear assembly by sliding on the front bearing, and thrust washer, if any.
- Install seal retaining ring into the groove provided on the shaft.
- Slide the mechanical seal head onto the shaft (metal end first) and position against the seal retaining ring. Use of a quality elastomer lubricant will aid in this step, remove excess.

NOTE: The lapped black carbon sealing face on the other end of the mechanical seal head must be clean and lubricated with light oil. It must also be free of marks or scratches when in contact with the seal wear face.

- Tighten the two seal head set screws, if provided, to insure it will rotate with the shaft and carefully insert the complete drive gear and shaft assembly into the pump body.
- Tighten in increments to maintain seal centering on the shaft.
- Assemble the lower front carbon bearing into pump body. Assemble front cover by engaging dowel pins into body. Insert socket head cap screws into front cover and thread into body, hand tight.
- Insert idle gear shaft assembly and remaining bearings into the pump body section.
- Assemble rear cover (no dowel pins) in the same manner as the front cover.

- Tighten screws in diagonal sequence carefully, please refer page no 6 for torque values. Rotate drive shaft by hand to insure alignment and pump looseness.

NOTE: Chemical Gear pump internal tolerances are held extremely close. Pump parts are manufactured to precise dimensions and most rigid quality control standards. The smallest foreign particle or damage in the form of a nick or gouge could jam the gears and bind the pump. Extreme cleanliness and care is essential for proper pump assembly.

Operating Temperatures and Pressures:

Please refer page no 4.

Starting:

Never start or run the pump dry. This will inevitably cause galling or seizing of the internal parts. Always prime the pump with the liquid being pumped or with a good grade of clean, light lubricating oil compatible with the pumped fluid. Before starting, rotate the pump by hand. It should rotate freely without tight spots. Check that all suction and discharge valves are open and that any relief valves have been "backed off". After priming, start the driver and allow pump to operate at a reduced load while observing for unreasonable noise, heat, or vibration. Check to be sure that pump is delivering liquid. If not, shutdown immediately and review foregoing instructions.

Gradually bring pump up to operating pressure by tightening relief valve adjustment until the pressure gauge indicates that the system design pressure has been reached. Again check pump for excessive noise, heat, or vibration. Check that the pump is delivering the required capacity and that the vacuum is not in excess of design conditions. If it is determined that the pump is meeting the required conditions, it is important to check that the driver is not overloaded.

Be sure that the overload protection for the electric motor is properly sized. Check that the electric motor is operating within the nameplate amperage limitations.

MAINTENANCE

General:

Chemical Gear pumps are designed to be lubricated by the liquid being pumped and therefore do not require lubrication maintenance. Barrel type carbon or PTFE bearings are self-lubricating.

Lubrication for a reduction gear drive, outboard bearing support and electric motor should be maintained as specified in the manufacturer's instructions furnished with the shipment.

PARTS LIST R102 / R103 / R104 / R106

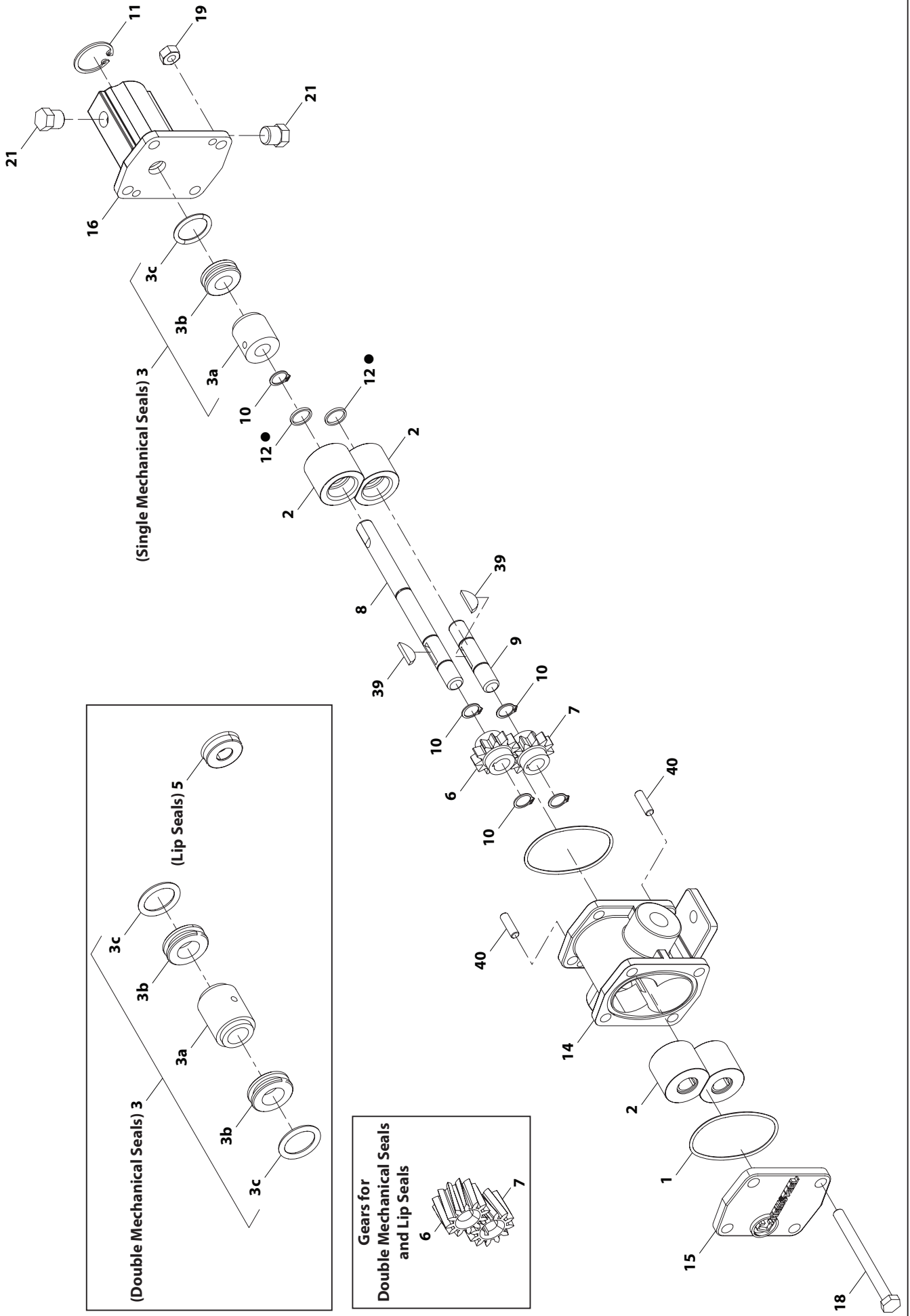

Figure 12

PARTS LIST RM102 / RM103 / RM104 / RM106

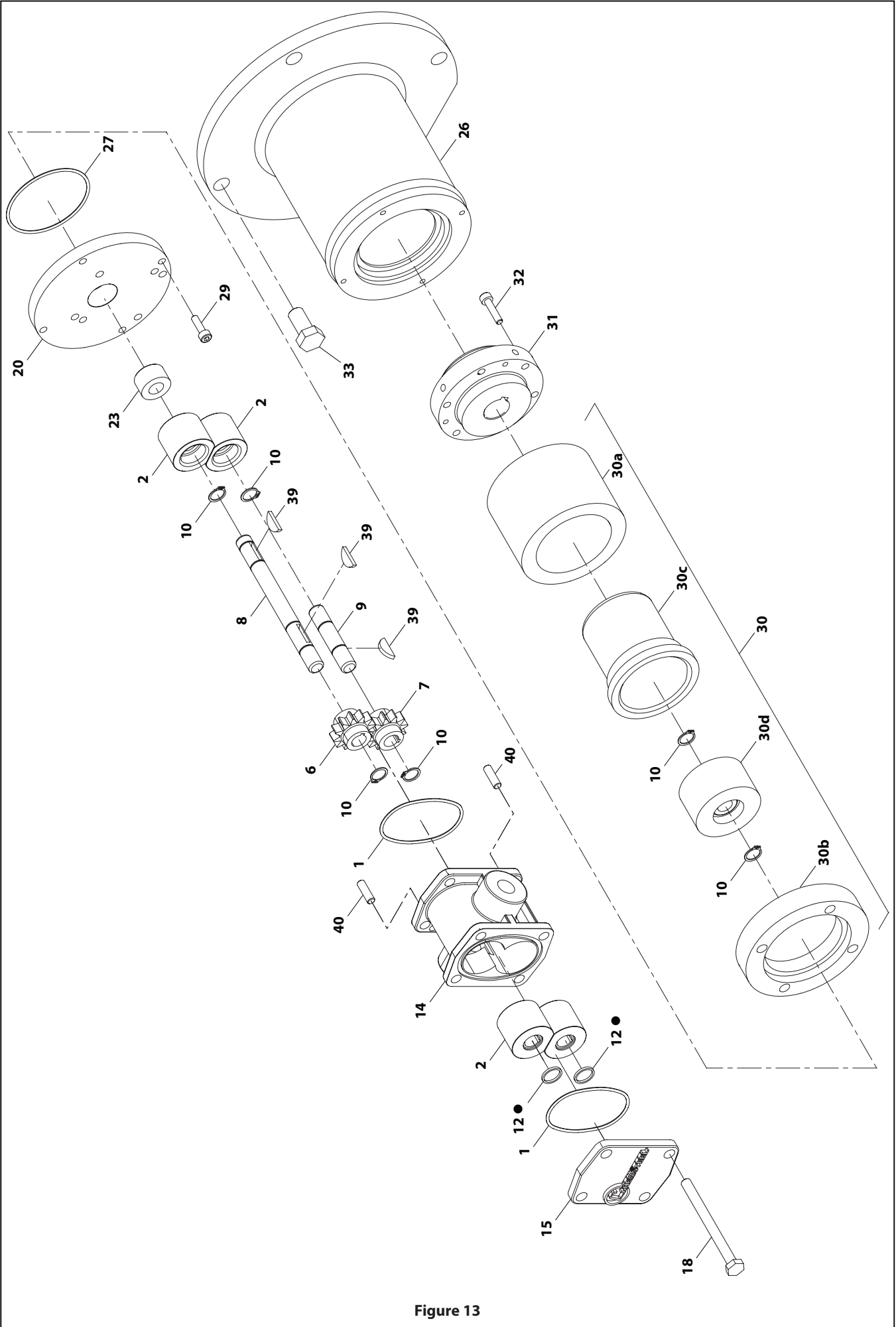

Figure 13

PARTS LIST R102 / R103 / R104 / R106 AND RM102 / RM103 / RM104 / RM106

▲ Item 3a, 3b and 3c are included in 3 (Mechanical Seal).

† Item 30a, 30b, 30c and 30d are included in 30 (Magnet kit).

★ Item 31, 32, 33, 34 and 35 (34 and 35 are not shown) are included in Mag power kit.

COMMON PARTS

Item	Description (size)	Qty	Part No.	Mtl	Item	Description (size)	Qty	Part No.	Mtl
1	O-Ring	2	OB9355-031	PTFE	23	Bearing (Mag Drive only)	1	OB2313	Carbon Graphite
▲ 3	Single Mechanical Seal	1	OB32674A	Seal Code A		Bearing (Mag Drive only)	1	OB2314	Rulon
	Single Mechanical Seal	1	OB32823	Seal Code D	26	Bell Housing (Mag Drive only)	1	OB2302-01	
	Single Mechanical Seal	1	OB33067	Seal Code C	27	O-Ring (Mag Drive only)	1	OB9355-033	PTFE
	Single Mechanical Seal	1	OB33068	Seal Code F	29	Hex Head Cap Screws (Bell/Pump Adapter) (Mag Drive only)	4	OB2481-014	316 SS
	Single Mechanical Seal	1	OB33065	Seal Code B	† 30	Magnet Kit, (Mag Drive only)	1	OB2023-3SS	Alloy C
	Single Mechanical Seal	1	OB33073	Seal Code J		Magnet Kit (Mag Drive only)	1	OB2023-3SH	316 SS
	Double Mechanical Seal	1	OB33075	Seal Code G	39	Key, Woodruff	2	OB9524	Hastelloy
	Double Mechanical Seal	1	OB33078	Seal Code H		Key, Woodruff (only for R103 / RM103)	1	OB9523	Hastelloy
Single Mechanical Seal	1	OB33131	Seal Code Z	40	Dowel Pin	2	OB9793	316 SS	
5	Lip Seal	2	OB2748	Seal Code L	● only for R2 and RM102 models				
● 12	Wave Spring (only for R2 and RM102 models)	2	OB2336	Alloy C	★ 35	Mounted Adapter Code (includes item 31, 32, 33, 34 and 35)	Kit Part No	Motor Frame	
14	Body (1/4" NPT Ports)	1	OB9127S-1P	316 SS		C1	M1AD56	56C	
	Body (1/4" NPT Ports)	1	OB9127H-1P	Alloy C		C2	M1AD45T	143TC 145TC	
15	Rear Cover	1	OB9128S-1	316 SS		C3	MR1T71E	IEC 71C, B14 Face	
	Rear Cover	1	OB9128H-1	Alloy C		C4	MR1T80E	IEC 80C, B14 Face	
16	Front Cover	1	OB9130S-3	316 SS					
	Front Cover	1	OB9130H-3	Alloy C					
	Front Cover, (Only Lip Seal)	1	OB9129S-5	316 SS					
18	Hex Head Cap Screws	4	OB9365-070	304 SS					
	Hex Head Cap Screws (Mag Drive)	4	OB9365-062	304 SS					
19	Hex Nuts	4	OB9367	304 SS					
20	Pump Adapter (Mag Drive only)	1	OB2312S	316 SS					
	Pump Adapter (Mag Drive only)	1	OB2312H	Alloy C					
21	Hex Head Pipe Plug	2	OB6600-01	316 SS					
	Hex Head Pipe Plug	2	OB6600-02	Alloy C					

BEARING OPTIONS R102 / RM102

Item	BEARING	Part No.	Qty	Mtl	BEARING CODE	
					C	P
2	BEARING	OB2318	4	Carbon Graphite	✓	
2		OB2316	4	PTFE		✓

BEARING OPTIONS R103 / RM103

Item	BEARING	Part No.	Qty	Mtl	BEARING CODE		
					C	P	J
2	BEARING	OB9236TC-A	4	Carbon Graphite	✓		
2		OB9804TC-A	4	PTFE		✓	
2		OB2204TC-A	4	Rulon			✓

BEARING OPTIONS R104 / RM104

Item	BEARING	Part No.	Qty	Mtl	BEARING CODE		
					C	P	J
2	BEARING	OB9235TC-A	4	Carbon Graphite	✓		
2		OB9400TC-A	4	PTFE		✓	
2		OB9425TC-A	4	Rulon			✓

BEARING OPTIONS R106 / RM106

Item	BEARING	Part No.	Qty	Mtl	BEARING CODE		
					C	P	J
2	BEARING	OB2777TC-A	4	Carbon Graphite	✓		
2		OB2778TC-A	4	PTFE		✓	
2		OB2205TC-A	4	Rulon			✓

PARTS LIST R102 / R103 / R104 / R106 AND RM101 / RM103 / RM104 / RM106

DRIVE GEAR / IDLE GEAR OPTIONS R102 / RM102

Item		Part No.	Qty	Mtl	GEAR CODE								
					2	3	4	5	7	9	E	F	
6	DRIVE GEAR	OB2315	1	316 SS	✓							✓	✓
6		OB2320	1	PEEK		✓							
6		OB2319	1	Alloy C		✓	✓				✓		
6		OB2317	1	PTFE					✓				
7	IDLE GEAR	OB2315	1	316 SS								✓	
7		OB2320	1	PEEK	✓	✓					✓		
7		OB2319	1	Alloy C			✓						
7		OB2317	1	PTFE				✓	✓				✓

DRIVE GEAR / IDLE GEAR OPTIONS R103 / RM103

Item		Part No.	Qty	Mtl	GEAR CODE													
					1	2	3	4	5	6	7	8	9	A	B	C	E	F
6	DRIVE GEAR	OB9296-01A	1	PPS	✓													
6		OB9717-01A	1	316 SS		✓									✓		✓	✓
6		OB9392-01A	1	PEEK			✓											
6		OB9188-01A	1	Alloy C				✓	✓				✓	✓				
6		OB9189-01A	1	W 88						✓		✓				✓		
6		OB9190-01A	1	PTFE							✓							
7	IDLE GEAR	OB9296-02A	1	PPS	✓									✓	✓	✓		
7		OB9717-02A	1	316 SS													✓	
7		OB9392-02A	1	PEEK		✓	✓						✓					
7		OB9188-02A	1	Alloy C				✓										
7		OB9189-02A	1	W 88						✓								
7		OB9190-02A	1	PTFE					✓		✓	✓						✓

DRIVE GEAR / IDLE GEAR OPTIONS R104 / RM104

Item		Part No.	Qty	Mtl	GEAR CODE													
					1	2	3	4	5	6	7	8	9	A	B	C	E	F
6	DRIVE GEAR	OB9656-01A	1	PPS	✓													
6		OB9698-01A	1	316 SS		✓									✓		✓	✓
6		OB9393-01A	1	PEEK			✓											
6		OB9149-01A	1	Alloy C				✓	✓				✓	✓				
6		OB9150-01A	1	W 88						✓		✓				✓		
6		OB9151-01A	1	PTFE							✓							
7	IDLE GEAR	OB9656-02A	1	PPS	✓									✓	✓	✓		
7		OB9698-02A	1	316 SS													✓	
7		OB9393-02A	1	PEEK		✓	✓						✓					
7		OB9149-02A	1	Alloy C				✓										
7		OB9150-02A	1	W 88						✓								
7		OB9151-02A	1	PTFE					✓		✓	✓						✓

DRIVE GEAR / IDLE GEAR OPTIONS R106 / RM106

Item		Part No.	Qty	Mtl	GEAR CODE													
					1	2	3	4	5	6	7	8	9	A	B	C	E	F
6	DRIVE GEAR	OB2368-01A	1	PPS	✓													
6		OB2365-01A	1	316 SS		✓									✓		✓	✓
6		OB2370-01A	1	PEEK			✓											
6		OB2366-01A	1	Alloy C				✓	✓				✓	✓				
6		OB2367-01A	1	W 88						✓		✓				✓		
6		OB2369-01A	1	PTFE							✓							
7	IDLE GEAR	OB2368-02A	1	PPS	✓									✓	✓	✓		
7		OB2365-02A	1	316 SS													✓	
7		OB2370-02A	1	PEEK		✓	✓						✓					
7		OB2366-02A	1	Alloy C				✓										
7		OB2367-02A	1	W 88						✓								
7		OB2369-02A	1	PTFE					✓		✓	✓						✓

PARTS LIST R102 / R103 / R104 / R106 AND RM102 / RM103 / RM104 / RM106

DRIVE SHAFT / IDLE SHAFT OPTIONS R102 / RM102 and R104 / RM104

Item	Description	Part No.	Qty	Mtl	GEAR CODE										
					A	B	C	D	F	G	H	J	Z	L	W
8	Drive Shaft (Single Mechanical Seals)	OB3127	1	316 SS	✓	✓	✓					✓	✓		
8	Drive Shaft (Single Mechanical Seals)	OB3128	1	Alloy C				✓	✓			✓			
8	Drive Shaft (Double Mechanical Seals)	OB3129	1	316 SS						✓	✓			✓	
8	Drive Shaft (Double Mechanical Seals)	OB3130	1	Alloy C						✓	✓				
8	Drive Shaft (Mag)	OB2306	1	316 SS											✓
8	Drive Shaft (Mag)	OB2307	1	Alloy C											✓
9	Idle Shaft	OB3131	1	316 SS	✓	✓	✓			✓	✓	✓	✓	✓	✓
9	Idle Shaft	OB3132	1	Alloy C				✓	✓	✓	✓				✓

DRIVE SHAFF / IDLE SHAFT OPTIONS R103 / RM103

Item	Description	Part No.	Qty	Mtl	GEAR CODE										
					A	B	C	D	F	G	H	J	Z	L	W
8	Drive Shaft (Single Mechanical Seals)	OB3119	1	316 SS	✓	✓	✓					✓	✓		
8	Drive Shaft (Single Mechanical Seals)	OB3120	1	Alloy C				✓	✓			✓			
8	Drive Shaft (Double Mechanical Seals)	OB3121	1	316 SS						✓	✓			✓	
8	Drive Shaft (Double Mechanical Seals)	OB3122	1	Alloy C						✓	✓				
8	Drive Shaft (Mag)	OB2331	1	316 SS											✓
8	Drive Shaft (Mag)	OB2332	1	Alloy C											✓
9	Idle Shaft	OB3123	1	316 SS	✓	✓	✓			✓	✓	✓	✓	✓	✓
9	Idle Shaft	OB3124	1	Alloy C				✓	✓	✓	✓				✓

DRIVE SHAFF / IDLE SHAFT OPTIONS R106 / RM106

Item	Description	Part No.	Qty	Mtl	GEAR CODE										
					A	B	C	D	F	G	H	J	Z	L	W
8	Drive Shaft (Single Mechanical Seals)	OB3012	1	316 SS	✓	✓	✓					✓	✓		
8	Drive Shaft (Single Mechanical Seals)	OB3013	1	Alloy C				✓	✓			✓			
8	Drive Shaft (Double Mechanical Seals)	OB3014	1	316 SS						✓	✓			✓	
8	Drive Shaft (Double Mechanical Seals)	OB3015	1	Alloy C						✓	✓				
8	Drive Shaft (Mag)	OB2337	1	316 SS											✓
8	Drive Shaft (Mag)	OB2338	1	Alloy C											✓
9	Idle Shaft	OB3016	1	316 SS	✓	✓	✓			✓	✓	✓	✓	✓	✓
9	Idle Shaft	OB3017	1	Alloy C				✓	✓	✓	✓				✓

RETAINING CLIP OPTIONS

Item	Description	Part No.	Mtl	GEAR CODE																					
				A Qty	B Qty	C Qty	D Qty	F Qty	G Qty	H Qty	J Qty	Z Qty	L Qty	W Qty											
10	Retaining Clip	OB2067	15-7 PH SS	✓	5	✓	5	✓	5	✓	5	✓	5	✓	4	✓	4	✓	5	✓	5	✓	4	✓	6
10	Retaining Clip	OB2068	Alloy C	✓	5	✓	5	✓	5	✓	5	✓	5	✓	4	✓	4	✓	5	✓	5	✓	4	✓	6

RETAINING RING OPTIONS

Item	Description	Part No.	Mtl	GEAR CODE																					
				A Qty	B Qty	C Qty	D Qty	F Qty	G Qty	H Qty	J Qty	Z Qty	L Qty	W Qty											
11	Retaining Ring	OB7065	15-7 PH SS	✓	1	✓	1	✓	1	✓	1	✓	1	✓	1	✓	1	✓	1	✓	1	✓	1	✓	3

SERVICE KITS

NOTE: Pump model should match the kit number exactly and end in K, if they don't see their pump listed, contact the factory for a new kit number.

PUMP MODEL	KIT TYPE	SERVICE KIT
OBR102	GEAR PUMP-STAINLESS CHEMKIT	OBR10212CAK
	GEAR PUMP-STAINLESS CHEMKIT	OBR10212CBK
	GEAR PUMP-STAINLESS CHEMKIT	OBR10212PBK
	GEAR PUMP STAINLESS KIT	OBR10213PBK
	GEAR PUMP-CHEMKIT STAINLESS	OBR10216CAK
	GEAR PUMP STAINLESS CHEMKIT	OBR10216CBK
	GEAR PUMP SS W/ALLOY C RINGS CHEMKIT	OBR10216CB-X1K
	GEAR PUMP-CHEMKIT STAINLESS	OBR10216JBK
	GEAR PUMP-STAINLESS CHEMKIT	OBR10216PBK
	GEAR PUMP-CHEMKIT STAINLESS	OBR10216PZK
	GEAR PUMP CHEMKIT STAINLESS	OBR1021DPBK
	GEAR PUMP CHEMKIT SST	OBR1021ECBK
	GEAR PUMP CHEM KIT SST	OBR1021FCHK
	GEAR PUMP CHEMKIT SST	OBR1021FPAK
	GEAR PUMP ALLOY C CHEMKIT	OBR10235CDK
	GEAR PUMP ALLOY C CHEMKIT	OBR10239CDK
	GEAR PUMP ALLOY C CHEMKIT	OBR10239PDK
	GEAR PUMP ALLOY C CHEMKIT	OBR10234CDK
OBRM102	GEAR PUMP - CHEMKIT- MAG SS	OBRM10212CWK
	GEAR PUMP MAG STAINLESS CHEMKIT	OBRM10212CW-T5K
	GEAR PUMP - CHEMKIT- MAG SS	OBRM10212PWK
	GEAR PUMP - CHEMKIT- MAG SS GRAINGER	OBRM10216CK
	GEAR PUMP - CHEMKIT- MAG SS	OBRM10216CWK
	GEAR PUMP-CHEMKIT-MAG SS	OBRM10216JWK
	GEAR PUMP-CHEMKIT-MAG SS	OBRM10216PWK
	GEAR PUMP - CHEMKIT- MAG SS	OBRM10218CWK
	GEAR PUMP MAG STAINLESS CHEMKIT	OBRM1021FCWK
	GEAR PUMP-MAG CHEMKIT ALLOY C	OBRM10234CWK
	GEAR PUMP-MAG CHEMKIT ALLOY C	OBRM10234JW-T12K
	GEAR PUMP-MAG CHEMKIT ALLOY C	OBRM10234PWK
	GEAR PUMP-MAG CHEMKIT ALLOY C	OBRM10235CWK
	GEAR PUMP-MAG CHEMKIT ALLOY C	OBRM10235JW-T12K
	GEAR PUMP-MAG CHEMKIT ALLOY C	OBRM10235PWK
	GEAR PUMP-MAG CHEMKIT ALLOY C	OBRM10237JWK
	GEAR PUMP-MAG CHEMKIT ALLOY C	OBRM10237PWK
	GEAR PUMP-MAG CHEMKIT ALLOY C	OBRM10239CWK
OBR103	GEAR PUMP-CHEMKIT STAINLESS	OBR10317PCK
	GEAR PUMP-CHEMKIT STAINLESS	OBR1031BCBK
	GEAR PUMP CHEMKIT STAINLESS	OBR1031DCAK
	GEAR PUMP-CHEMKIT STAINLESS	OBR1031ECBK
	GEAR PUMP-CHEMKIT STAINLESS	OBR1031FCBK
	GEAR PUMP-CHEMKIT STAINLESS	OBR1031FJAK
	GEAR PUMP-CHEMKIT STAINLESS	OBR10311CAK
	GEAR PUMP-CHEMKIT STAINLESS	OBR10311CBK
	GEAR PUMP - STAINLESS - CHEMKIT	OBR10312CAK
	GEAR PUMP CHEMKIT STAINLESS	OBR10312CBK
	GEAR PUMP - STAINLESS - CHEMKIT	OBR10312CCK
	GEAR PUMP CHEMKIT STAINLESS	OBR10312JAK
	GEAR PUMP-CHEMKIT STAINLESS	OBR10316CAK
	GEAR PUMP-CHEMKIT STAINLESS	OBR10316CBK
	GEAR PUMP CHEMKIT STAINLESS	OBR10316CCK
	GEAR PUMP-CHEMKIT STAINLESS	OBR10316JBK
	GEAR PUMP-CHEMKIT STAINLESS	OBR10316JCK
	GEAR PUMP-CHEMKIT STAINLESS	OBR10316PBK

SERVICE KITS

PUMP MODEL	KIT TYPE	SERVICE KIT
OBR103	GEAR PUMP-CHEMKIT STAINLESS	OBR10317PBK
	GEAR PUMP-CHEMKIT STAINLESS	OBR10317PCK
	GEAR PUMP-CHEMKIT STAINLESS	OBR1031BCBK
	GEAR PUMP CHEMKIT STAINLESS	OBR1031DCAK
	GEAR PUMP-CHEMKIT STAINLESS	OBR1031ECBK
	GEAR PUMP-CHEMKIT STAINLESS	OBR1031FCBK
	GEAR PUMP-CHEMKIT STAINLESS	OBR1031FJAK
	GEAR PUMP-CHEMKIT STAINLESS	OBR10311CAK
	GEAR PUMP-CHEMKIT STAINLESS	OBR10311CBK
	GEAR PUMP - STAINLESS - CHEMKIT	OBR10312CAK
	GEAR PUMP CHEMKIT STAINLESS	OBR10312CBK
	GEAR PUMP - STAINLESS - CHEMKIT	OBR10312CCK
	GEAR PUMP CHEMKIT STAINLESS	OBR10312JAK
	GEAR PUMP-CHEMKIT STAINLESS	OBR10316CAK
	GEAR PUMP-CHEMKIT STAINLESS	OBR10316CBK
	GEAR PUMP CHEMKIT STAINLESS	OBR10316CCK
	GEAR PUMP-CHEMKIT STAINLESS	OBR10316JBK
	GEAR PUMP-CHEMKIT STAINLESS	OBR10316JCK
	GEAR PUMP-CHEMKIT STAINLESS	OBR10316PBK
	GEAR PUMP-CHEMKIT STAINLESS	OBR10317PBK
OBRM103	GEAR PUMP MAG STAINLESS CHEMKIT	OBRM10312CWK
	GEAR PUMP MAG STAINLESS CHEMKIT	OBRM10316CWK
	GEAR PUMP MAG SS CHEMKIT FFKM ORINGS	OBRM10316CW-X1K
	GEAR PUMP MAG SS CHEMKIT VITON ORINGS	OBRM10316CW-X2K
	GEAR PUMP MAG STAINLESS CHEMKIT	OBRM10316JMK
	GEAR PUMP MAG STAINLESS CHEMKIT	OBRM10316JWK
	GEAR PUMP MAG STAINLESS CHEMKIT	OBRM10316PWK
	GEAR PUMP MAG STAINLESS CHEMKIT	OBRM10318CWK
	GEAR PUMP MAG STAINLESS CHEMKIT	OBRM1031ECWK
	GEAR PUMP MAG STAINLESS CHEMKIT	OBRM1031FCWK
	GEAR PUMP MAG STAINLESS CHEMKIT	OBRM1031FPWK
	GEAR PUMP MAG ALLOY C CHEMKIT	OBRM10334CWK
	GEAR PUMP ALLOY C CHEMKIT	OBRM10335PWK
GEAR PUMP MAG ALLOY C CHEMKIT	OBRM10339CWK	
OBR104	GEAR PUMP-CHEMKIT SST	OBR10411CAK
	GEAR PUMP-CHEMKIT SST	OBR10411CBK
	GEAR PUMP-CHEMKIT SST	OBR10411JBK
	GEAR PUMP-CHEMKIT SST	OBR10412CBK
	GEAR PUMP-CHEMKIT SST	OBR10412CCK
	GEAR PUMP-CHEMKIT STAINLESS	OBR10416CAK
	GEAR PUMP-CHEMKIT SST	OBR10416CBK
	GEAR PUMP-CHEMKIT STAINLESS	OBR10416CCK
	GEAR PUMP-CHEMKIT SST	OBR10416CJK
	GEAR PUMP-CHEMKIT SST	OBR10416CZK
	GEAR PUMP-CHEMKIT STAINLESS	OBR10416JAK
	GEAR PUMP-CHEMKIT STAINLESS	OBR10416PAK
	GEAR PUMP-CHEMKIT SST	OBR1041BCAK
	GEAR PUMP-CHEMKIT SST	OBR1041BCBK
	GEAR PUMP-CHEMKIT SST	OBR1041ECBK
	GEAR PUMP-CHEMKIT SST	OBR1041ECCK
	GEAR PUMP-CHEMKIT SST	OBR1041FCBK
	GEAR PUMP-CHEMKIT SST	OBR1041FJBK
GEAR PUMP-CHEMKIT SST	OBR1041FPBK	
GEAR PUMP-CHEMKIT SST	OBR1041FPCK	

SERVICE KITS

PUMP MODEL	KIT TYPE	SERVICE KIT
OBRM104	GEAR PUMP MAG STAINLESS CHEMKIT	OBRM10411JWK
	GEAR PUMP MAG STAINLESS CHEMKIT	OBRM10412CWK
	GEAR PUMP MAG STAINLESS CHEMKIT	OBRM10416CWK
	GEAR PUMP CHEMKIT MAG SST SILICONE	OBRM10416CW-X1K
	GEAR PUMP MAG STAINLESS CHEMKIT	OBRM10416JWK
	GEAR PUMP MAG STAINLESS CHEMKIT	OBRM1041ECWK
	GEAR PUMP MAG STAINLESS CHEMKIT	OBRM1041FCWK
	GEAR PUMP MAG STAINLESS CHEMKIT	OBRM1041FPWK
	GEAR PUMP-MAG CHEMKIT ALLOY C	OBRM10434CWK
	GEAR PUMP-MAG CHEMKIT ALLOY C	OBRM10435CWK
	GEAR PUMP-MAG CHEMKIT ALLOY C	OBRM10435JWK
OBR106	GEAR PUMP STAINLESS CHEMKIT	OBR10611CBK
	GEAR PUMP-STAINLESS CHEMKIT	OBR10612CAK
	GEAR PUMP-STAINLESS CHEMKIT	OBR10612JH-T1K
	GEAR PUMP-CHEMKIT STAINLESS	OBR10616CAK
	GEAR PUMP-CHEMKIT STAINLESS	OBR10616CCK
	GEAR PUMP-CHEMKIT STAINLESS	OBR10616CJK
	GEAR PUMP-CHEMKIT STAINLESS	OBR10616PBK
	GEAR PUMP CHEMKIT STAINLESS	OBR10618CBK
	GEAR PUMP STAINLESS CHEMKIT	OBR1061BCAK
	GEAR PUMP STAINLESS CHEMKIT	OBR1061BCBK
GEAR PUMP-STAINLESS CHEMKIT	OBR1061FPAK	
OBRM106	GEAR PUMP MAG STAINLESS CHEMKIT	OBRM10612CWK
	GEAR PUMP MAG STAINLESS CHEMKIT	OBRM10612CW-T1K
	GEAR PUMP STAINLESS MAG CHEMKIT	OBRM10612JWK
	GEAR PUMP SST HOUS ALLOY C INT CHEMKIT	OBRM10614JWK
	GEAR PUMP - CHEMKIT- MAG SS	OBRM10616CWK
	GEAR PUMP - CHEMKIT- MAG SS	OBRM10616JWK
	GEAR PUMP STAINLESS MAG CHEMKIT	OBRM1061BCWK
	GEAR PUMP MAG STNLSS CHEMKIT	OBRM1061FCWK
	GEAR PUMP MAG STNLSS CHEMKIT	OBRM1061FPWK
	GEAR PUMP CHEMKIT MAG SS	OBRM1061HCWK
	GEAR PUMP ALLOY C MAG CHEMKIT	OBRM10634CWK
	GEAR PUMP ALLOY C MAG CHEMKIT	OBRM10635PWK
GEAR PUMP ALLOY C MAG CHEMKIT	OBRM10639CWK	

DIMENSIONAL DATA

R102 / R103 / R104 / R106 PEDESTAL MOUNT DIMENSIONS

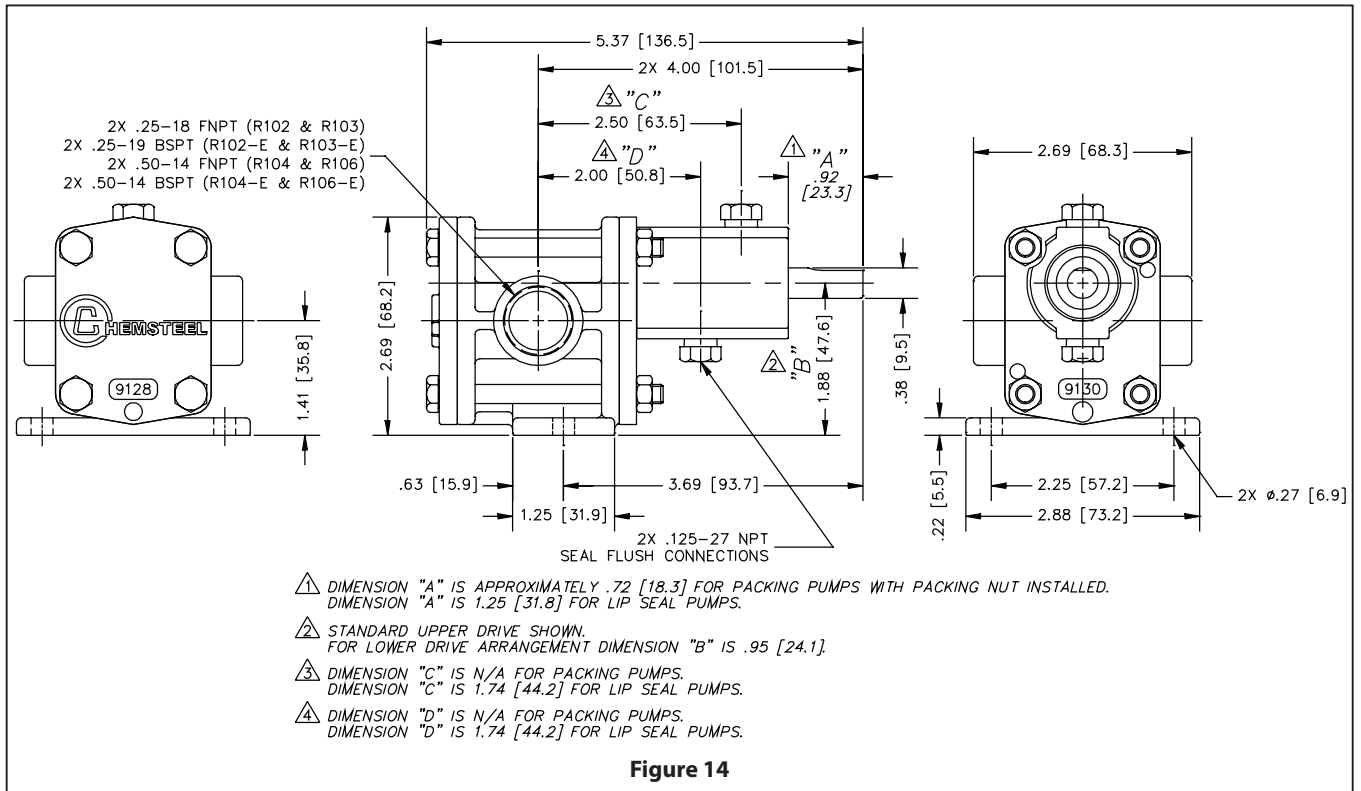

DIMENSIONAL DATA

RM102 / RM103 / RM104 / RM106 CLOSE-COUPLED DIMENSION

CLOSE - COUPLED DIMENSIONS C1 and C2:

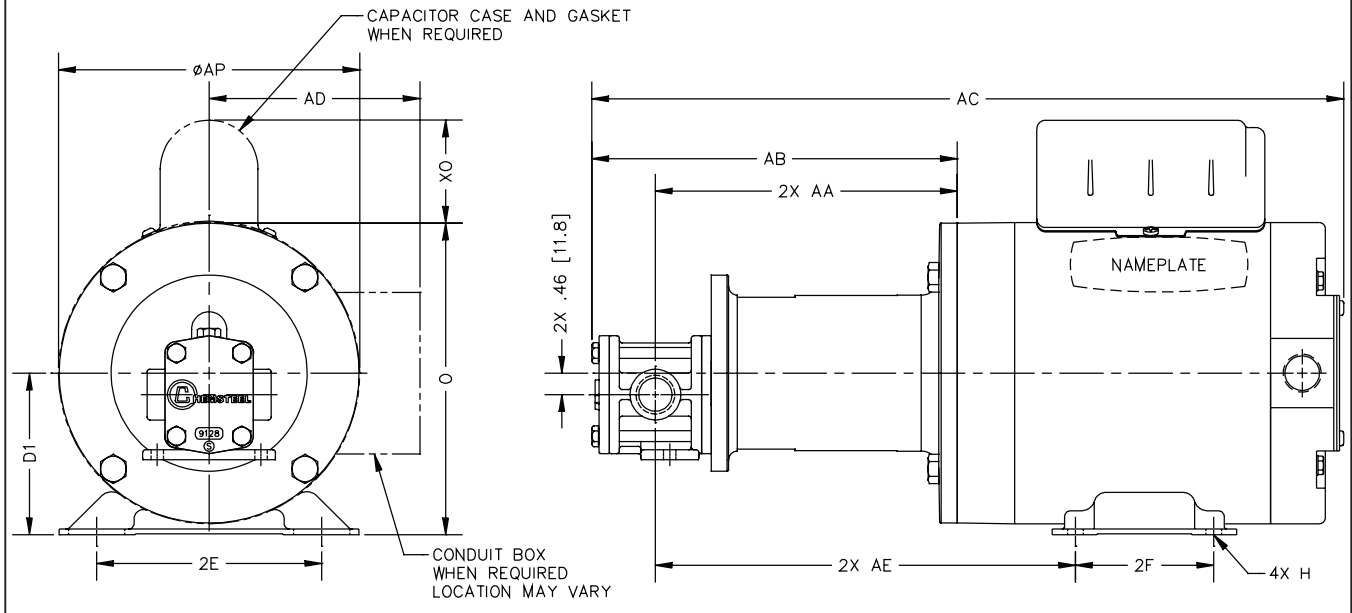

Figure 15

Mounted Adapter Code	Kit Part No	Motor Frame		D1	2E	2F	H	⓪ O	⓪ AP	⓪ XO	AA	AB	⓪ AC	⓪ AD	AE
C1	M1AD56	56C	Inches	3.50	4.88	3.00	Ø 0.34 Slot	6.88	6.63	2.25	6.54	7.92	16.30	---	9.11
			mm	88.9	124	76.2	Ø 8.6 Slot	174.8	168.4	57.2	166.1	201.2	414.0	---	231.4
C2	M1AD45T	143TC 145TC	Inches	3.50	5.50	4.00 5.00	Ø 0.34 Slot	6.88	6.63	2.25	6.54	7.92	17.49 18.99	4.57	8.93
			mm	88.9	139.7	102 127	Ø 8.6 Slot	174.8	168.4	57.2	166.1	201.2	444.2 482.3	116.1	226.8

⓪ These Dimensions vary depending on HP, Enclosure and Motor manufacture. Specifications are subject to change without notification.

CLOSE - COUPLED DIMENSIONS C3 and C4:

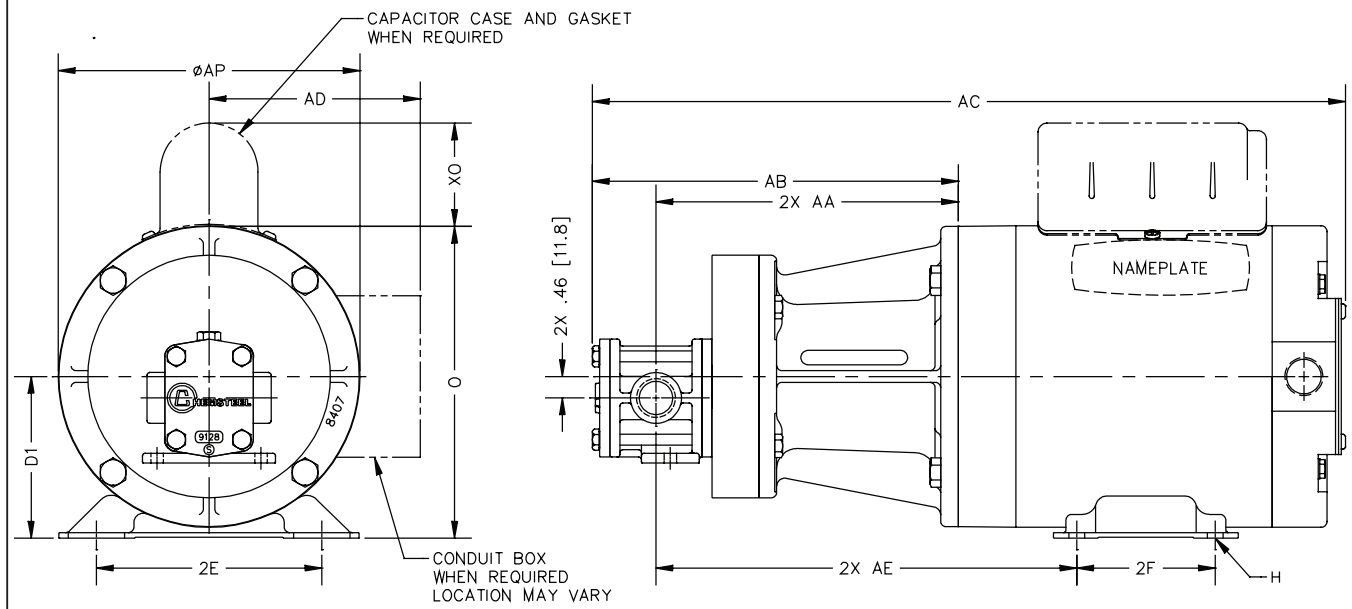

Figure 16

Mounted Adapter Code	Kit Part No	Motor Frame		D1	2E	2F	H	⓪ O	⓪ AP	⓪ XO	AA	AB	⓪ AC	⓪ AD	AE
C3	M1AD71E	IEC 71, B14 Face	Inches	2.80	4.41	3.54	Ø 0.28 Slot	5.14	4.69	---	6.05	7.43	16.74	4	7.82
			mm	71	112	89.9	Ø 7 Slot	130.6	119.1	---	153.7	188.7	425.2	102	198.6
C4	M1AD80E	IEC 80, B14 Face	Inches	3.15	4.92	3.94	Ø 0.39 Slot	6	5.69	---	6.05	7.43	16.97	4.51	8.02
			mm	80	125	100.1	Ø 10 Slot	152.4	144.5	---	153.7	188.7	431	116	203.7

⓪ These Dimensions vary depending on HP, Enclosure and Motor manufacture. Specifications are subject to change without notification.

TROUBLESHOOTING

PROBLEM	PROBABLE CAUSE	REMEDY
No liquid delivered.	1. Pump not primed.	1. Reprime pump, check that pump and there are no obstructions in the suction line.
	2. Discharge valve closed	2. Check discharge valve.
	3. Suction line clogged.	3. Remove obstructions.
	4. Wrong direction of rotation.	4. Change rotation to concur with direction indicated on bearing housing or pump casing.
	5. Total head is too high.	5. Re-evaluate head conditions.
	6. Driver is not operating at rated speed.	6. Check electric motor voltage; check engine rpm.
	7. Pump is vapor bound	7. Manually add some liquid to pump inlet to assist priming.
	8. Foot valve or suction pipe opening not submerged enough	8. Consult factory for proper depth. Use baffle to eliminate vortices.
Pump not producing rated flow or head.	1. Air leak through seal (suction lift condition)	1. Replace seal
	2. Outlet clogged	2. Check outlet piping
	3. Worn suction side plate or wear rings.	3. Replace defective parts as required.
	4. Pump is not properly primed.	4. Reprime pump, check that pump and there are no obstructions in the suction line. Check NPSHa to ensure that there is enough liquid for pump operation.
	5. Driver is not operating at rated speed.	5. Check electric motor voltage; check engine rpm
	6. Pump is vapor bound	6. Provide additional pressure on liquid being pumped by elevating liquid source. or consider installing an air release valve in the discharge line to remove the air to allow the pump to become dynamic.
	7. Insufficient suction head.	7. Ensure that suction line shutoff valve is fully open and line is unobstructed.
	8. Worn or broken gear.	8. Inspect and replace if necessary.
Pump starts then stops pumping.	1. Excessive air in liquid.	1. Clean and tighten all suction connections; relocate suction inlet in liquid source.
	2. Defective packing or seal.	2. Replace packing or seal.
	3. Pump is vapor bound.	3. Provide additional pressure on liquid being pumped by elevating liquid source. or consider installing an air release valve in the discharge line to remove the air to allow the pump to become dynamic.
	4. Air or vapor pockets in suction line.	4. Rearrange piping to eliminate air pockets.
	5. Air leak in suction line.	5. Repair leak.
	6. Back pressure too high (mag drive)	6. Reduce back pressure, increase pump size
Bearings or magnet run hot.	1. Improper alignment.	1. Re-align pump and drive.
	2. Improper lubrication.	2. Check lubricate for suitability and level.
	3. Lube cooling.	3. Check cooling system
	4. Magnet flush port clogged	4. Clear orifice plug (see parts list)

TROUBLESHOOTING

PROBLEM	PROBABLE CAUSE	REMEDY
Pump is noisy or vibrates.	1. Improper pump/driver alignment.	1. Align shafts.
	2. Broken gear or bent shaft	2. Replace as required.
	3. Foundation not rigid.	3. Tighten bolts of pump and motor or adjust stilts
	4. Worn bearings.	4. Replace.
	5. Suction or discharge piping not anchored or properly supported.	5. Anchor per Hydraulic Institute Standards Manual recommendation.
	6. Pump is cavitating.	6. Check NPSHa, Air leaks to ensure that there is enough liquid for pump operation.
Excessive leakage from stuffing box/seal chamber.	1. Worn mechanical seals.	1. Replace worn parts.
	2. Overheating mechanical seal.	2. Check lubrication and cooling lines.
	3. Shaft damage	3. Replace as required
Motor requires excessive power.	1. Reduce motor RPM	1. Check fluid viscosity, Consult factory.
	2. Speed is too high.	2. Electric motor wiring is wrong. Replace motor.
	3. Wrong direction of rotation.	3. Check wiring diagram.
	4. Gear or bearing swell.	4. Check torque required to turn pump. lap rear bearings .001 if needed.
	5. Gears are binding.	5. Check for particulate in pump or swell from chemical exposure.
	6. Driver and pump are misaligned.	6. Realign driver with pump.
	7. Power frame shaft is bent.	7. Replace shaft.
	8. Liquid heavier than expected.	8. Check specific gravity and viscosity.
	9. Rotating parts bind.	9. Check internal wearing parts for proper clearances
Pump fails to prime or loses its prime.	1. Air leaks in suction line.	1. Clean and tighten all suction connections; relocate suction inlet in liquid source.
	2. Suction strainer is clogged. Suction lift is too high.	2. Clean debris from strainer. Re-evaluate pump requirements and correct suction conditions.
	3. Defective priming valve.	3. Replace valve.
	4. Defective seal.	4. Replace seal.
Insufficient pressure.	1. Excessive air in liquid.	1. Clean and tighten all suction connections; relocate suction inlet in liquid source.
	2. Driver is not operating at rated speed.	2. Check electric motor voltage; check engine rpm
	3. Wrong direction of rotation.	3. Change rotation to concur with direction.
	4. Total head is too high.	4. Re-evaluate head conditions. may lead to magnet decoupling
	5. Worn suction side plate or wear rings.	5. Replace defective parts as required.
	6. Broken or bent drive shaft.	6. Replace as required.
	7. Air leak through O-rings.	7. Replace gasket.
	8. Liquid is vaporizing	8. Provide additional pressure on liquid being pumped by elevating liquid source. Check temperature of liquid being pumped'