

SELF-PRIMING CENTRIFUGAL PUMP

SERIES "A" INCLUDING AG MISER 3 AND 5

PARTSLIST
PP-9910
Aug. 2000

EXPLODED VIEW PARTS DIAGRAM

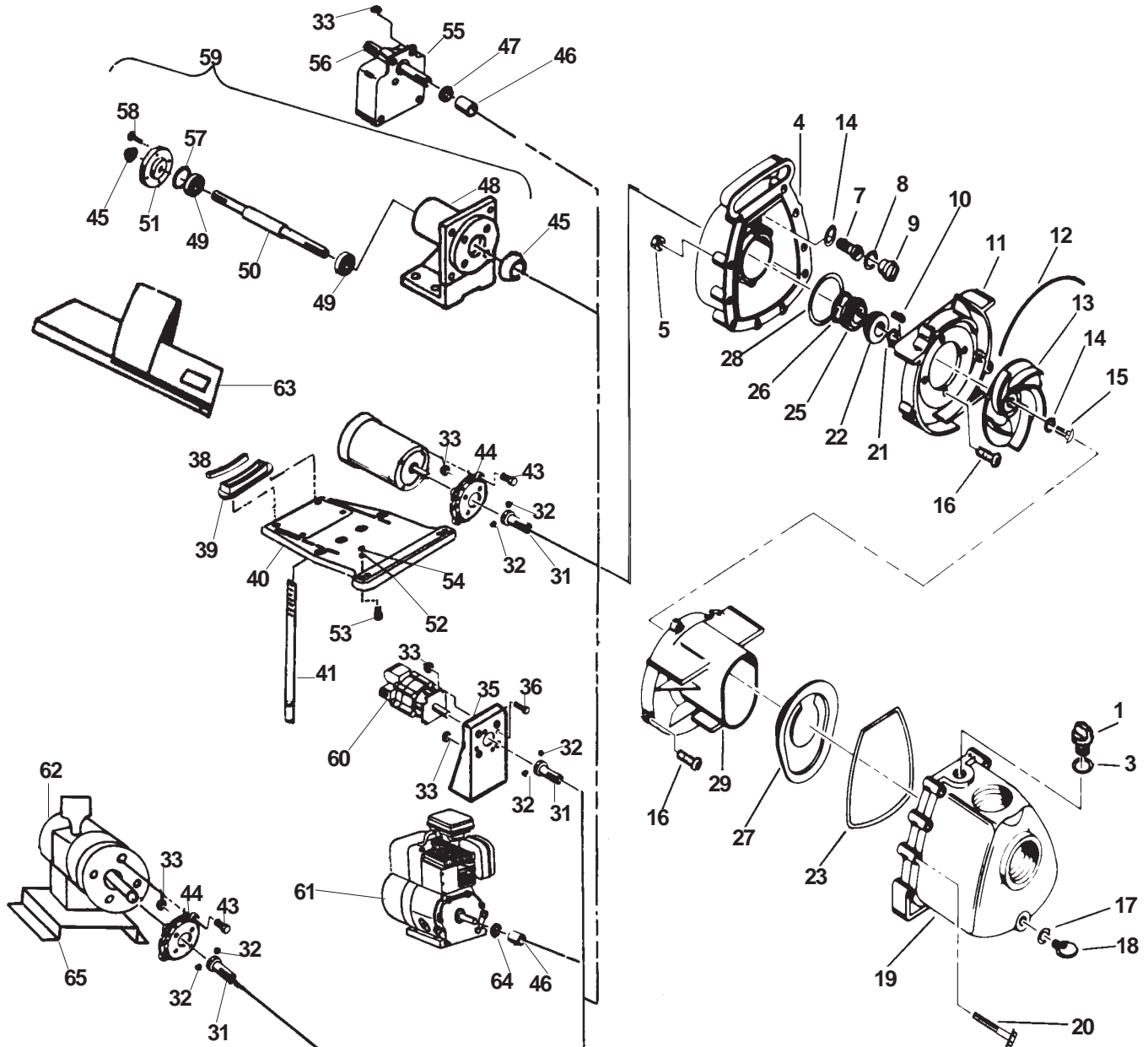

ITEM #	PART #	DESCRIPTION	QTY.	ITEM #	PART #	DESCRIPTION	QTY.
1	58-0722 30B	PLUG, Filler, Black Polyester	1	58-1245 72	O-RING, Screw Plug, EPDM	4	
	58-0722 40	PLUG, Filler, Gray Polypropylene	1	58-1245 73	O-RING, Screw Plug, VITON	4	
3	58-0765 71	O-RING, Filler Plug, BUNA-N	1	9	58-1233 30	PLUG, Screw, Black Polyester	4
	58-0765 72	O-RING, Filler Plug, EPDM	1		58-1233 40	PLUG, Screw, Gray Polypropylene	4
	58-0765 73	O-RING, Filler Plug, VITON	1	10	58-0718	KEY, 3/16" Sq. x 15/16" Long, Steel	1
4	58-1262 30B	BRACKET, Black Polyester	1		58-0718 10	KEY, 3/16" Sq. x 15/16" Long, Stainless Steel	1
	58-1262 40	BRACKET, Gray Polypropylene	1	11	58-1302 30	VOLUTE, Rear, Black Polyester	1
5	58-0721	NUT, Plated Steel, 1/4"-20	10		58-1302 40	VOLUTE, Rear, Gray Polypropylene	1
	58-0721 10	NUT, Stainless Steel, 1/4"-20	10	12	58-1246 71	O-RING, Segment, BUNA-N	1
	58-0721 10F	FLANGE NUT, BODY, Stainless Steel, 1/4"-20, for Polypropylene pumps only	10		58-1246 72	O-RING, Segment, EPDM	1
7	58-0715 10	SCREW, 5/16-24 x 1.25" Long, Stainless Steel, for Pumps close-coupled to engines and cast pedestal mounted	4		58-1246 73	O-RING, Segment, VITON	1
	58-0728 10	SCREW, 5/16-18 x 1.5" Long, Stainless Steel, for Pumps close-coupled to electric, hydraulic, or thermoplastic bearing pedestal	4	13	58-0683 30	IMPELLER, Black Polyester	1
8	58-1245 71	O-RING, Screw Plug, BUNA-N	4		58-0683 40	IMPELLER, Gray Polypropylene	1
				14	58-0717 71	O-RING, Screw, BUNA-N	5
					58-0717 72	O-RING, Screw, EPDM	5
					58-0717 73	O-RING, Screw, VITON	5
				15	58-0716 10	SCREW, Impeller, 5/16-24 x .75" Long, Stainless Steel	1

"A" PUMP PARTS LIST

ITEM #	PART #	DESCRIPTION	QTY./PUMP
16	58-1348 10	SCREW, Volute, #10 x .75", Stainless Steel	7
17	58-1009 71	O-RING, Drain Plug, BUNA-N	1
	58-1009 72	O-RING, Drain Plug, EPDM	1
	58-1009 73	O-RING, Drain Plug, VITON	1
18	58-0723 30	PLUG, Drain, Black Polyester	1
	58-0723 40	PLUG, Drain, Gray Polypropylene	1
19	58-1261 30B	BODY, 2" NPT, Black Polyester	1
	58-1261 40	BODY, 2" NPT, Gray Polypropylene	1
	58-1873 30B	BODY, 2" BSP, Black Polyester	1
20	58-0720	SCREW, Body, Plated Steel, 1/4"-20 x 2-3/8"	10
	58-0720 10	SCREW, Body, Stainless Steel, 1/4"-20 x 2-3/8"	10
21	58-0778 11	SHIM, Impeller, .006", Stainless Steel	as required
	58-0778 12	SHIM, Impeller, .015", Stainless Steel	as required
	58-0778 13	SHIM, Impeller, .030", Stainless Steel	as required
22, 25 & 26	58-0714 11	SHAFT SEAL, BUNA-N	1
	58-0714 12	SHAFT SEAL, EPDM	1
	58-0714 14	SHAFT SEAL, VITON	1
23	58-1926 71	O-RING, Body, BUNA-N	1
	58-1926 72	O-RING, Body, EPDM	1
	58-1926 73	O-RING, Body, VITON	1
26	58-0976 71	O-RING, Shaft Seal, BUNA-N	1
	58-0976 72	O-RING, Shaft Seal, EPDM	1
	58-0976 73	O-RING, Shaft Seal, VITON	1
27	58-1872 71	CHECK VALVE, BUNA-N	1
	58-1872 72	CHECK VALVE, EPDM	1
	58-1872 73	CHECK VALVE, VITON	1
28	58-1203 71	O-RING, Rear Volute, BUNA-N	1
	58-1203 72	O-RING, Rear Volute, EPDM	1
	58-1203 73	O-RING, Rear Volute, VITON	1
29	58-1303 30	VOLUTE, Front, Flat, Black Polyester	1
	58-1303 60	VOLUTE, Front, Flat, Brown Ryton (used only in Polypropylene pumps)	1
	58-1304 31	VOLUTE, Front, Black Polyester, BUNA Lined	1
	58-1304 32	VOLUTE, Front, Black Polyester, EPDM Lined	1
31	58-1014 10	ADAPTER, Shaft, .625" Dia. Bore, Stainless Steel, for Close-Coupled Electric or Pneumatic Motor	1
	58-1165 10	ADAPTER, Shaft, .563" Dia. Bore, Stainless Steel, for Hydraulic Motor	1
32	58-0883	SCREW, Set, 1/4"-20 x 1/4" Long, Steel	2
33	58-0745	NUT, Keps, 5/16"-18, Plated Steel	4
35	58-1011 20	BASE, Hydraulic Motor, Molded Plastic	1
36	58-0729 H	SCREW, 5/16"-18 x 1" Long, Plated Steel	4
38	58-1826 71	PAD, Rubber, Saddle	1
39	58-1828 90	SADDLE, Electric Motor, NEMA 56 Frame Motor	1
	58-1825 90	SADDLE, Electric Motor, NEMA 48 Frame Motor	1
40	58-1823 40	BASE PLATE, CC Motor, Polypropylene	1
41	58-0934 10	STRAP, Electric Motor, Stainless Steel	1
43	58-1015 10	SCREW, Hex Cap, 3/8"-16 x 1.25" Long, Stainless Steel	4
44	58-1010 20	ADAPTER, CC Motor, Molded Plastic	1
45	58-1955 71	LIP SEAL, BUNA-N	2
46	58-0882 90	SHAFT SLEEVE, Polyethylene	1
47	58-0884 71	SLINGER, BUNA-N	1
48	58-1951 90	HOUSING, Bearing, Cast Iron	1
49	58-1954 90	BEARING	2
50	58-1952 10	SHAFT, Stainless Steel	1
51	58-1953 10	END PLATE, Stainless Steel	1
52	58-0730	FLAT WASHER, .563", Plated Steel	2
53	58-0729	SCREW, Plated Steel, 5/16"-18 x 1"	2
54	58-0745	NUT, Keps, 5/16"-18, Plated Steel	2
55	58-0759 20	BEARING PEDESTAL, Molded Plastic	1
56	58-0777	BEARING/SHAFT ASSEMBLY, Standard, Carbon Steel Shaft	1
	58-0777 10	BEARING/SHAFT ASSEMBLY, with Stainless Steel Shaft Sleeve	1
57	58-1956 10	SHIM, Bearing Shaft, Pedestal, .006", Stainless Steel	as required
58	58-2525 10	SCREW, Hx. Hd. 1/4"-20 x 3/4", Stainless Steel	4
59	58-1950 01	ASSEMBLY, Bearing Pedestal (Consists of Items 45, 48, 49, 50, 51, 57 & 58)	1
60	58-0686	MOTOR, Hydraulic	1
61	58-0634	ENGINE, B & S, 3.5HP, Recoil Start	1
	58-0633 AP	ENGINE, B & S, 3.5HP, Industrial Plus, Recoil Start	1
	58-0644	ENGINE, B & S, 5.5HP, OHV Intek, Recoil Start	1
	58-0644 A	ENGINE, B & S, 5.5HP, OHV Intek I/C, Recoil Start	1
	58-0635 H	ENGINE, Honda, 5.5HP OHV, Recoil Start	1
62	58-0926	MOTOR, Pneumatic	1
63	58-0028	BASE PLATE KIT, Std. Duty, Call Factory For Details	1
	58-0016	BASE PLATE KIT, Heavy Duty, Call Factory For Details	1
64	58-0881 72	GASKET, Engine Protection, EPDM, 5HP only	1
	58-0933 72	GASKET, Engine Protection, EPDM, 3.5HP only	1
65	58-0929	BASE PLATE, Steel, For Pneumatic Motor	1

NOTE: All specifications, as shown, subject to change without notice.

F.O.B. Lancaster, PA

Minimum Order: \$25.00 Net

Terms: Net 30 Days

Distributed by:

PACER® PUMPS

Div. of ASM Industries, Inc.

**servicing
industry
world-
wide**

41 Industrial Circle 717-656-2161
Lancaster, PA 17601-5927 800-233-3861
Email:sales@pacerpumps.com FAX: 717-656-0477

Printed in U.S.A.