



# Rule Livewell Pumps



## Easy Motor Replacement

A simple and convenient “push and twist button” motor cartridge removal system makes it easy to remove and replace the motor cartridge when fitted in hard-to-reach areas of the boat.

## Good Fishing Begins with Good Bait

For over 50 years, boat builders and owners have depended on Rule pumps for a fun day out on the water. Building on that legacy of marine performance, Xylem’s Rule Livewell Pumps have been designed to deliver superior performance and unsurpassed quality – making it the perfect choice for keeping bait and catch alive.

To meet the needs of today’s faster watercraft, this livewell pump can withstand the pressures of high-speed water intake scoops. Other features that provide enhanced operation and reliability:

- High efficiency pump design for optimal bait health
- Simple one hand twist & click motor cartridge removal/replacement
- Inlets for straight thru-hull, angled thru-hull and seacock installations
- Secondary inlet port for washdown pump connection
- Advanced anti-airlock protection

### High-Efficiency Motor and Impeller Design

The advanced engineering of the Rule Livewell Pumps ensures more efficient water circulation, which is crucial for maintaining the well-being of bait/catch in the livewell.

### Adaptable to Different Setups and Configurations

All Rule Livewell Pumps are supplied with threaded nylon hose barb attachments, making them adaptable to different setups and configurations and allowing for versatile hose mounting options.

### High Inlet Pressure Capability for High-Speed Vessels

While other livewell pumps are not engineered to withstand the additional water pressures of boats with high-speed pickup scoops, the Rule Livewell Pumps feature a high inlet pressure capability that can keep up with the demands of more powerful boats.

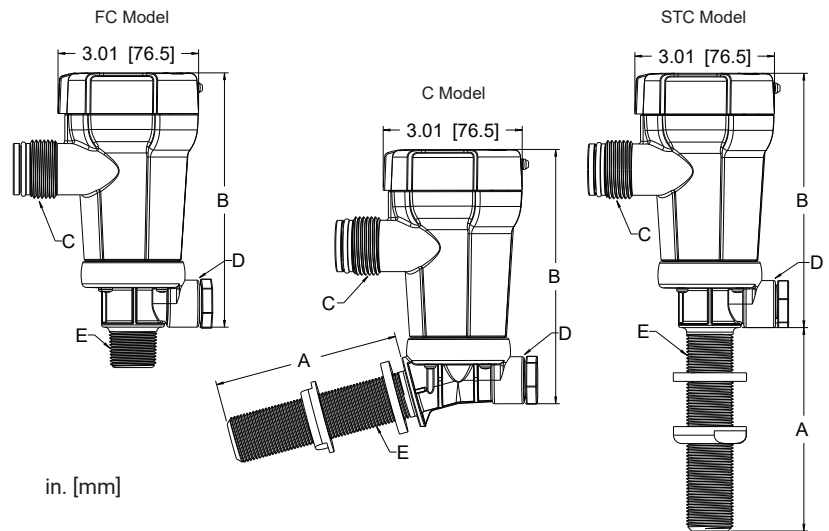

in. [mm]

	A	B	C	D	E
<b>FC Model</b>	-	5.62 (142.8)	1-11.5 NPSM	1/2-14 NPT	3/4-14 NPT
<b>C Model</b>	4.11 (104.4)	5.62 (142.8)	1-11.5 NPSM	1/2-14 NPT	3/4-14 NPSM
<b>STC Model</b>	4.5 (114.3)	5.62 (142.8)	1-11.5 NPSM	1/2-14 NPT	3/4-14 NPSM

Model Number	601FC	603FC	605FC	601STC	603STC	605STC	601C	603C	605C
Open Flow	500 GPH	800 GPH	1100 GPH	500 GPH	800 GPH	1100 GPH	500 GPH	800 GPH	1100 GPH
Inlet Style	Straight Seacock	Straight Seacock	Straight Seacock	Straight Thru-hull	Straight Thru-hull	Straight Thru-hull	Angled Thru-hull	Angled Thru-hull	Angled Thru-hull
Inlet Size - NPT	3/4" NPT Thread	3/4" NPT Thread	3/4" NPT Thread	3/4" NPSM Thread	3/4" NPSM Thread	3/4" NPSM Thread	3/4" NPSM Thread	3/4" NPSM Thread	3/4" NPSM Thread
Discharge Size – Hose Barb	3/4"	3/4"	1 1/8"	3/4"	3/4"	1 1/8"	3/4"	3/4"	1 1/8"
Voltage	12 VDC	12 VDC	12 VDC	12 VDC	12 VDC	12 VDC	12 VDC	12 VDC	12 VDC
Amp Draw @ 12V DC	3.0 Amp	4.1 Amp	4.7 Amp	3.0 Amp	4.1 Amp	4.7 Amp	3.0 Amp	4.1 Amp	4.7 Amp
Fuse Size	5 Amp	7.5 Amp	7.5 Amp	5 Amp	7.5 Amp	7.5 Amp	5 Amp	7.5 Amp	7.5 Amp
Replacement Motor Cartridge PN	65DR	66DR	67DR	65DR	66DR	67DR	65DR	66DR	67DR



Scan the QR code to access the product page for complete product details.

