

TECHNAFLO

D & T SERIES PUMPS

ENGINEERING DATA PACK



IR Ingersoll Rand®

TABLE OF CONTENTS

| | |
|---|----|
| D Series Model Number System | 3 |
| D Series Mounting Dimensions (Displacements .11 to 2.3) | 4 |
| T Series Model Number System..... | 5 |
| T Series Mounting Dimensions (Displacements 2.6 to 12.) | 6 |
| Pump Performance Data | 7 |
| Temperature Limits | 8 |
| Temperature Effect on Magnet Torque | 9 |
| Materials of Construction..... | 10 |
| Regulatory Compliance Information..... | 11 |



WARNING

The magnets in magnetically coupled pumps create very strong magnetic fields. Special care must be taken with the following:

- **Pacemakers** - Magnets can upset the timing of pacemakers. These magnets should be kept away from all pacemakers. Because of the health risks involved the importance of this cannot be overstated.
- **Credit Cards** - Magnets can scramble the information on a credit card's magnetic tape.
- **Computers, Computer Tapes, and Computer Disks** - Magnets can scramble the information on the memory device.
- **Watches** - Magnets can affect the workings of traditional mechanical spring-driven watches as well as chip and electronically controlled designs.
- **Electronic Instruments** - Sensitive electronic instruments and devices may change calibration or be damaged by a powerful magnetic field.
- **Explosive Atmosphere** - Rare earth magnets and magnetic materials may create sparks through contact in handling. Never handle rare earth magnets in explosive atmospheres because sparking may ignite the atmosphere.
- Do not place hand or fingers between the housing and adapter. The magnets are extremely strong and will attract all metallic objects and can be the source of pinch points. Do not wear watches or other metallic jewelry when working with magnets.

D SERIES MODEL NUMBER SYSTEM

| POSITIONS | SERIES | MAGNET TORQUE | MATERIALS OF CONSTRUCTION | DISPLACEMENT mL/REV | | | GEAR & BEARING MATERIAL | | | O-RING | PORT SIZE | MAGNET | BYPASS | MOTOR & DRIVE | OPEN | OPERATING TEMPERATURE | OPEN |
|-----------|--------|---------------|---------------------------|---------------------|---|---|-------------------------|---|----|--------|-----------|--------|--------|---------------|------|-----------------------|------|
| | D | G | S | . | 6 | 8 | P | P | P | T | 1 | N | M | 9 | 7 | 0 | 0 |
| 1 | 2 | 3 | 4 | 5 | 6 | 7 | 8 | 9 | 10 | 11 | 12 | 13 | 14 | 15 | 16 | 17 | 18 |

POS. 1 - PUMP SERIES

D = 1.67" Diameter Metal Pump

POS. 2 - MAGNET TORQUE

B* = 30 oz/in

G = 65 oz/in

X = 240 oz/in

*Not available for 1.2, 1.3, 1.6, 2.0, or 2.3

POS. 3 - MATERIALS OF CONSTRUCTION

S = 316 Stainless Steel

H = Hastelloy C276

T = Titanium

POS. 4, 5, & 6 - DISPLACEMENT mL/REV

.11 = Nominal 6 GPH at 3500 RPM

.19 = Nominal 10 GPH at 3500 RPM

.23 = Nominal 12 GPH at 3500 RPM

.38 = Nominal 20 GPH at 3500 RPM

.57 = Nominal 30 GPH at 3500 RPM

.68 = Nominal 36 GPH at 3500 RPM

.80 = Nominal 42 GPH at 3500 RPM

.99 = Nominal 52 GPH at 3500 RPM

1.2 = Nominal 63 GPH at 3500 RPM

1.3 = Nominal 68 GPH at 3500 RPM

1.6 = Nominal 84 GPH at 3500 RPM

2.0 = Nominal 105 GPH at 3500 RPM

2.3 = Nominal 121 GPH at 3500 RPM

POS. 7, 8, & 9 - GEAR & BEARING MATERIAL

PPP = PPS (Polyphenylene Sulfide)

EEE = PEEK (Polyetheretherketone)

TTT* = PTFE

* Available in .23, .38, .57, .68, .80, 1.2, and 1.6 only.

Requires PTFE O-rings and welded magnet.

Maximum Differential Pressure = 100 PSI

POS. 10 - O-RING

V = Viton

T = PTFE

E = EPR

POS. 11 - PORT SIZE

1* = 1/8" NPT

2 = 1/4" NPT

*Not available for .99, 1.2, 1.3, 1.6, 2.0, or 2.3 sizes. Not available in Hastelloy or Titanium

POS. 12 - MAGNET

N = PPS or PEEK Encapsulated
(Material based on Pos. 7, 8, & 9)

W = Welded
(Required for PTFE gears, Hastelloy, Titanium pumps. Welded not available in B size magnet)

POS. 13 - BYPASS

N = None

M = Medium 60 PSI (Standard)

L = Low Pressure 30 PSI (Low Pressure not available in .99 to 2.3 sizes)

H = High Pressure 130 PSI (High Pressure not available in .99 to 2.3 sizes)

Bypass is not available in Hastelloy or Titanium

POS. 14 & 15 - MOTOR & DRIVE

00 = Pump Only

POS. 16 - OPEN

0 = Open

POS. 17 - OPERATING TEMPERATURES

PTFE = 140°F (60°C)

PPS = 250°F (121°C) Polyphenylene Sulfide

PEEK = 350°F (176°C) Polyetheretherketone

Note: Temperatures greater than 140°F (60°C) may reduce flow/pressure. These are approximate gear & bearing maximum temperature limits

POS. 18 - OPEN

0 = Open

SERVICE PACK OPTION

Add "SP" in front of the model number, followed by positions 1-10, 16, 17, & 18 of pump model

Note: SPDB, SPDG, & SPDX default to SPDD (Example - SPDD1.2PPPT000)

Service Pack Contains:

- Gears
- Bearings
- O-Rings
- Lubricant
- Instruction Sheet

D SERIES PUMP MOUNTING DIMENSIONS

All measurements are in inches [millimeters].

Displacement .11 to 2.3

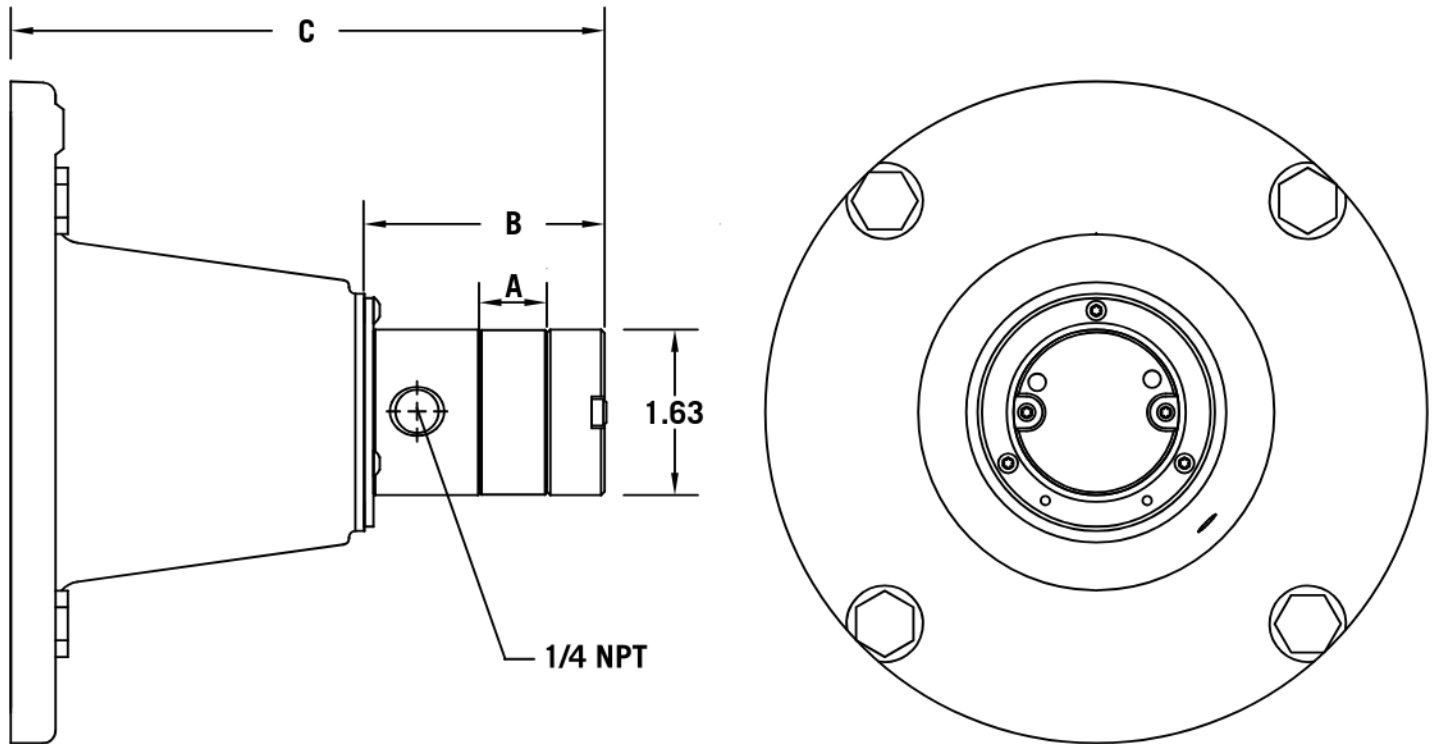

D SERIES DISPLACEMENTS .11 TO 2.3

| DISPLACEMENT | DIMENSION A | DIMENSION B | DIMENSION C |
|--------------|-----------------|----------------|-----------------|
| .11 & .19 | 0.125" [3.2mm] | 1.83" [46.4mm] | 5.30" [134.6mm] |
| .23 & .38 | 0.250" [6.4mm] | 1.95" [49.5mm] | 5.42" [137.7mm] |
| .57 | 0.375" [9.5mm] | 2.07" [52.7mm] | 5.54" [140.7mm] |
| .68 & .80 | 0.450" [11.4mm] | 2.15" [54.7mm] | 5.62" [142.7mm] |
| .99 & 1.2 | 0.657" [16.7mm] | 2.36" [59.9mm] | 5.83" [148.1mm] |
| 1.3 | 0.750" [19.0mm] | 2.45" [62.3mm] | 5.92" [150.4mm] |
| 1.6 & 2.0 | 0.900" [22.9mm] | 2.60" [66.0mm] | 6.07" [154.2mm] |
| 2.3 | 1.000" [25.4mm] | 2.70" [68.6mm] | 6.17" [156.7mm] |

NOTE: In conjunction with our program of continuous testing and design upgrading, all specifications are subject to change without notice. All data is approximate. Request a quotation for your specific application.

T SERIES MODEL NUMBER SYSTEM

| POSITIONS | SERIES | MAGNET TORQUE | MATERIALS OF CONSTRUCTION | DISPLACEMENT mL/REV | | | GEAR & BEARING MATERIAL | | | O-RING | PORT SIZE | MAGNET | BYPASS | MOTOR & DRIVE | OPEN | OPERATING TEMPERATURE | OPEN |
|-----------|--------|---------------|---------------------------|---------------------|---|---|-------------------------|---|----|--------|-----------|--------|--------|---------------|------|-----------------------|------|
| | T | X | S | 5 | - | 3 | P | P | P | T | 3 | N | N | A | 2 | 0 | 0 |
| 1 | 2 | 3 | 4 | 5 | 6 | 7 | 8 | 9 | 10 | 11 | 12 | 13 | 14 | 15 | 16 | 17 | 18 |

POS. 1 - PUMP SERIES

T = 3" Diameter Metal Pump

POS. 2 - MAGNET TORQUE

X = 240 oz/in
(Required for 2.6, 5.3, and 7.9 sizes)

W = 460 oz/in
(Required for 8.0 and 12. sizes)

POS. 3 - MATERIALS OF CONSTRUCTION (WETTED)

S = 316 Stainless Steel
H = Hastelloy C276
T = Titanium

POS. 4, 5, & 6 - DISPLACEMENT mL/REV

2.6 = Nominal 137 GPH at 3500 RPM
5.3 = Nominal 279 GPH at 3500 RPM
7.9 = Nominal 416 GPH at 3500 RPM
8.0 = Nominal 421 GPH at 3500 RPM
12. = Nominal 650 GPH at 3500 RPM

POS. 7, 8, & 9 - GEAR & BEARING MATERIAL

PPP = PPS (Polyphenylene Sulfide)
EEE = PEEK (Polyetheretherketone)

POS. 10 - O-RING

V = Viton
T = PTFE
E = EPR

POS. 11 - PORT SIZE

3 = 3/8" NPT
(Required for 2.6, 5.3, and 7.9 sizes)

7 = 3/4" NPT Suction, 1/2" NPT on Discharge
(Required for 8.0 and 12. sizes)

POS. 12 - MAGNET

N = PPS or PEEK Encapsulated
(Material based on Pos. 7, 8, & 9)

W = Welded
(Required for Hastelloy or Titanium pumps.
Not available for Stainless)

POS. 13 - BYPASS

N = Not available

POS. 14 & 15 - MOTOR & DRIVE

00 = Pump Only

POS. 16 - OPEN

0 = Open

POS. 17 - OPERATING TEMPERATURES

PPS = 250°F (121°C) Polyphenylene Sulfide
PEEK = 350°F (176°C) Polyetheretherketone

Note: Temperatures greater than 140°F (60°C) may reduce flow/pressure. These are approximate gear & bearing maximum temperature limits

POS. 18 - OPEN

0 = Open

SERVICE PACK OPTION

Add "SP" in front of the model number, followed by positions 1-10, 16, 17, & 18 of pump model

Service Pack Contains:

- Gears
- Bearings
- O-Rings
- Lubricant
- Instruction Sheet

T SERIES PUMP MOUNTING DIMENSIONS

All measurements are in inches [millimeters].

Displacement 2.6 to 7.9

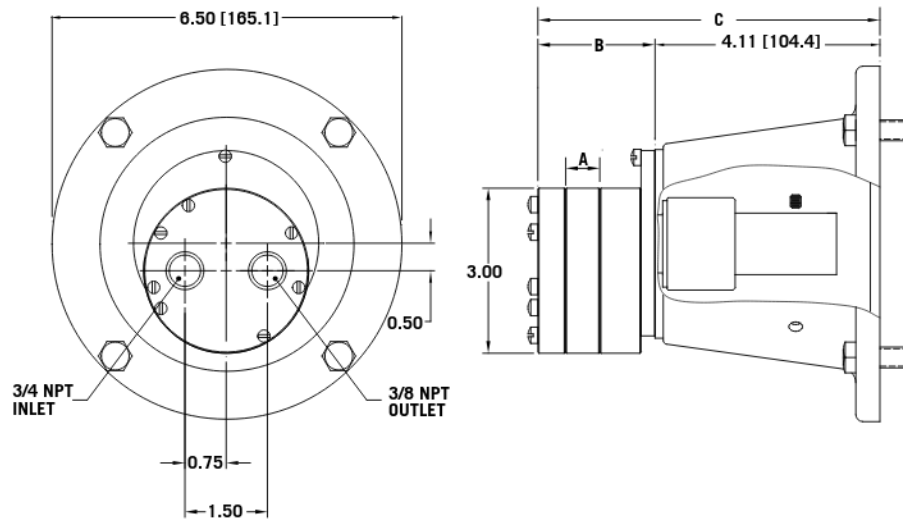

T SERIES DISPLACEMENTS 2.6 TO 7.9

| DISPLACEMENT | DIMENSION A | DIMENSION B | DIMENSION C |
|--------------|-----------------|----------------|-----------------|
| 2.6 | 0.313" [7.95mm] | 1.82" [46.2mm] | 5.93" [150.6mm] |
| 5.3 | 0.625" [15.8mm] | 2.12" [53.8mm] | 6.24" [158.5mm] |
| 7.9 | 0.938" [23.8mm] | 2.43" [61.8mm] | 6.55" [166.4mm] |

Displacement 8.0 to 12.

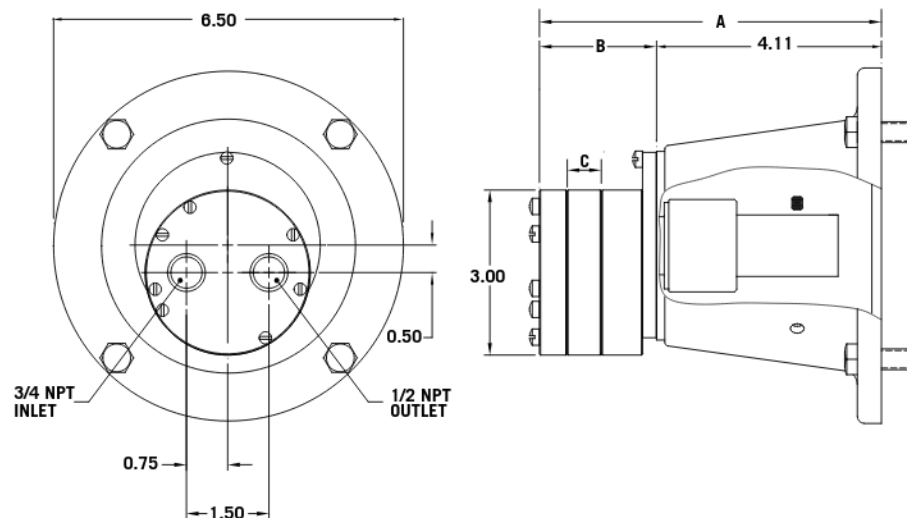

T SERIES DISPLACEMENTS 8.0 TO 12.

| DISPLACEMENT | DIMENSION A | DIMENSION B | DIMENSION C |
|--------------|-----------------|----------------|-----------------|
| 8.0 | 7.00" [177.8mm] | 2.65" [59.7mm] | 0.625" [15.9mm] |
| 12. | 7.32" [185.9mm] | 3.21" [81.4mm] | 0.938" [23.8mm] |

NOTE: In conjunction with our program of continuous testing and design upgrading, all specifications are subject to change without notice. All data is approximate. Request a quotation for your specific application.

D SERIES PUMP PERFORMANCE DATA

| SIZE (mL/rev) | GPH @ 0 PSI and 3500 RPM | LPH @ 0 PSI and 3500 RPM | MAX DIFFERENTIAL PRESSURE PSI (BAR) |
|---------------|--------------------------|--------------------------|--|
| .11 | 6 GPH | 22 LPH | 150 PSI (10.3 BAR) |
| .19 | 10 GPH | 38 LPH | 150 PSI (10.3 BAR) |
| .23 | 12 GPH | 46 LPH | 250 PSI (17.2 BAR) |
| .38 | 20 GPH | 76 LPH | 250 PSI (17.2 BAR) |
| .57 | 30 GPH | 114 LPH | 250 PSI (17.2 BAR) |
| .68 | 36 GPH | 136 LPH | 250 PSI (17.2 BAR) |
| .80 | 42 GPH | 160 LPH | 250 PSI (17.2 BAR) |
| .99 | 52 GPH | 198 LPH | 200 PSI (13.8 BAR) |
| 1.2 | 63 GPH | 239 LPH | 200 PSI (13.8 BAR) |
| 1.3 | 69 GPH | 259 LPH | 175 PSI (12.1 BAR) |
| 1.6 | 84 GPH | 319 LPH | 150 PSI (10.3 BAR) |
| 2.0 | 105 GPH | 399 LPH | 150 PSI (10.3 BAR) |
| 2.3 | 121 GPH | 459 LPH | 150 PSI (10.3 BAR) |

NOTE: Maximum system pressure is 500 PSI (34.5 BAR) and viscosity range is 0.3 - 2000 cPs without speed reduction.

T SERIES PUMP PERFORMANCE DATA

| SIZE (mL/rev) | GPH @ 0 PSI and 3500 RPM | LPH @ 0 PSI and 3500 RPM | MAX DIFFERENTIAL PRESSURE PSI (BAR) |
|---------------|--------------------------|--------------------------|--|
| 2.6 | 137 GPH | 518 LPH | 250 PSI (17.2 BAR) |
| 5.3 | 279 GPH | 1056 LPH | 145 PSI (10 BAR) |
| 7.9 | 416 GPH | 1575 LPH | 95 PSI (6.6 BAR) |
| 8.0 | 421 GPH | 1593 LPH | 150 PSI (10.3 BAR) |
| 12. | 650 GPH | 2460 LPH | 120 PSI (8.3 BAR) |

NOTE: Maximum system pressure is 500 PSI (34.5 BAR) and viscosity range is 0.3 - 2000 cPs without speed reduction.

D & T SERIES TEMPERATURE LIMITS

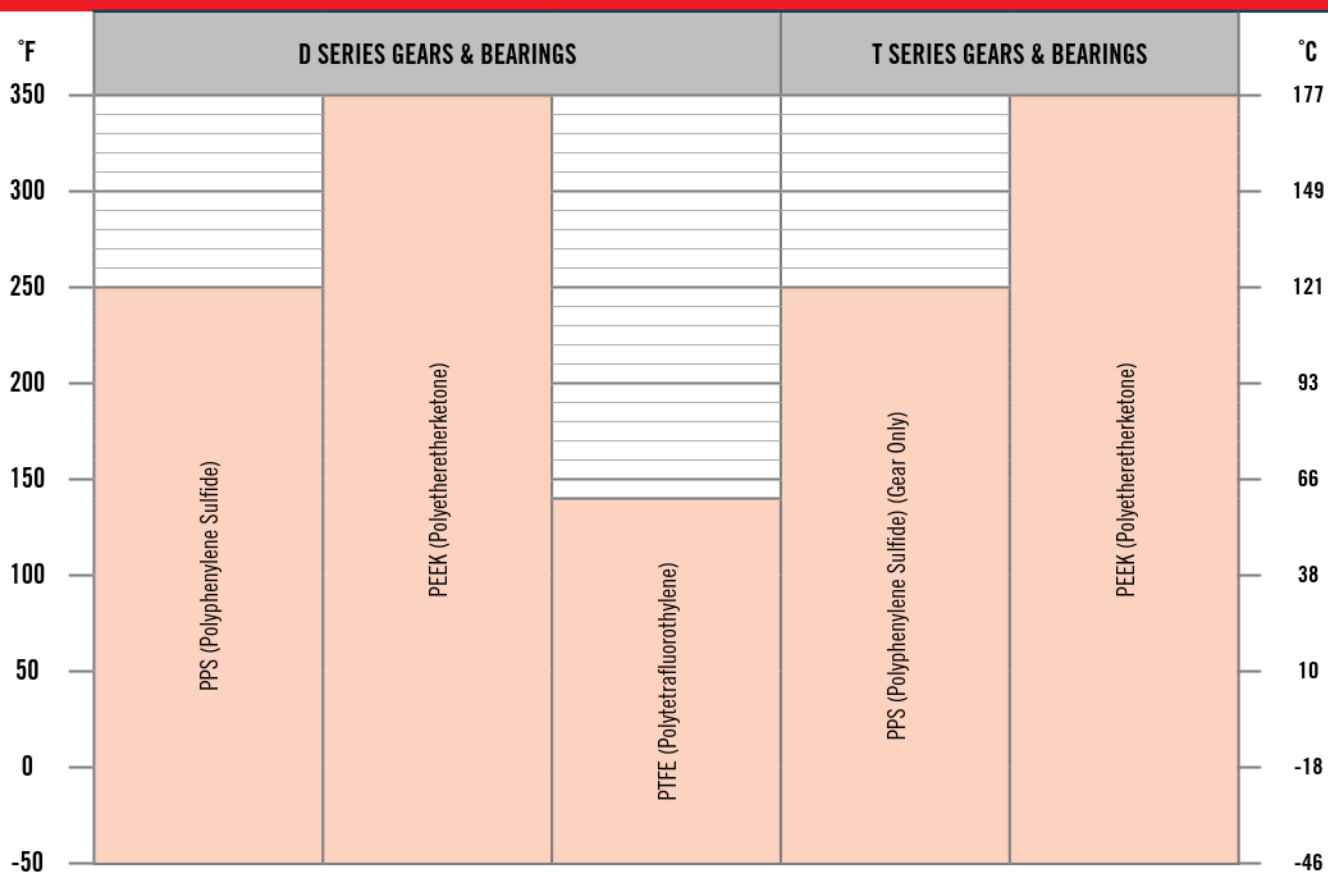

TEMPERATURE EFFECT ON MAGNET TORQUE

| TEMPERATURE | | TORQUE | | MAGNET TORQUE | | | | | | | |
|--------------|-----|---------|-------|---------------|------|-------|-------|-------------------|-------|--------|--------|
| °C | °F | PERCENT | | OUNCE INCH | | | | MILLINEWTON METER | | | |
| B, G, X, & W | | B & G | X & W | B | G | X | W | B | G | X | W |
| 22 | 72 | 100% | 100% | 30.0 | 65.0 | 240.0 | 460.0 | 211.8 | 459.0 | 1694.8 | 3248.3 |
| 30 | 86 | 98% | 99% | 29.4 | 63.7 | 238.1 | 456.4 | 207.6 | 449.8 | 1681.4 | 3222.9 |
| 40 | 104 | 96% | 98% | 28.7 | 62.1 | 235.8 | 452.0 | 202.6 | 438.5 | 1665.1 | 3191.8 |
| 50 | 122 | 93% | 97% | 27.9 | 60.5 | 233.5 | 447.5 | 197.0 | 427.2 | 1648.9 | 3160.0 |
| 60 | 140 | 91% | 96% | 27.2 | 58.8 | 231.1 | 443.0 | 192.1 | 415.2 | 1631.9 | 3128.3 |
| 70 | 158 | 88% | 95% | 26.4 | 57.2 | 228.8 | 438.6 | 186.4 | 403.9 | 1615.7 | 3097.2 |
| 80 | 176 | 86% | 94% | 25.7 | 55.6 | 226.5 | 434.1 | 181.5 | 392.6 | 1599.4 | 3065.4 |
| 90 | 194 | 83% | 93% | 24.9 | 54.0 | 224.2 | 429.6 | 175.8 | 381.3 | 1583.2 | 3033.6 |
| 100 | 212 | 81% | 92% | 24.2 | 52.3 | 221.8 | 425.2 | 170.9 | 369.3 | 1566.3 | 3002.6 |
| 110 | 230 | 78% | 91% | 23.4 | 50.7 | 219.5 | 420.7 | 165.2 | 358.0 | 1550.0 | 2970.8 |
| 120 | 248 | 76% | 90% | 22.7 | 49.1 | 217.2 | 416.3 | 160.3 | 346.7 | 1533.8 | 2939.7 |
| 130 | 266 | 73% | 90% | 21.9 | 47.5 | 214.8 | 411.8 | 154.6 | 335.4 | 1516.8 | 2907.9 |
| 140 | 284 | 71% | 89% | 21.2 | 45.8 | 212.5 | 407.3 | 149.7 | 323.4 | 1500.6 | 2876.2 |
| 150 | 302 | 68% | 88% | 20.4 | 44.2 | 210.2 | 402.9 | 144.1 | 312.1 | 1484.3 | 2845.1 |
| 160 | 320 | 66% | 87% | 19.7 | 42.6 | 207.9 | 398.4 | 139.1 | 300.8 | 1468.1 | 2813.3 |
| 170 | 338 | 63% | 86% | 18.9 | 41.0 | 205.5 | 393.9 | 133.5 | 289.5 | 1451.2 | 2781.6 |
| 180 | 356 | 61% | 85% | 18.2 | 39.3 | 203.2 | 389.5 | 128.5 | 277.5 | 1434.9 | 2750.5 |
| 190 | 374 | 58% | 84% | 17.4 | 37.7 | 200.9 | 385.0 | 122.9 | 266.2 | 1418.7 | 2718.7 |
| 200 | 392 | 56% | 83% | 16.7 | 36.1 | 198.6 | 380.6 | 117.9 | 254.9 | 1402.4 | 2687.6 |
| 210 | 410 | 53% | 82% | 15.9 | 34.5 | 196.2 | 376.1 | 112.3 | 243.6 | 1385.5 | 2655.9 |
| 220 | 428 | 51% | 81% | 15.2 | 32.8 | 193.9 | 371.6 | 107.3 | 231.6 | 1369.2 | 2624.1 |
| 230 | 446 | 48% | 80% | 14.4 | 31.2 | 191.6 | 367.2 | 101.7 | 220.3 | 1353.0 | 2593.0 |
| 240 | 464 | 46% | 79% | 13.7 | 29.6 | 189.2 | 362.7 | 96.7 | 209.0 | 1336.1 | 2561.2 |
| 250 | 482 | 43% | 78% | 12.9 | 28.0 | 186.9 | 358.2 | 91.1 | 197.7 | 1319.8 | 2529.5 |
| 260 | 500 | 41% | 77% | 12.2 | 26.3 | 184.6 | 353.8 | 86.2 | 185.7 | 1303.6 | 2498.4 |

D & T SERIES PUMPS MATERIALS OF CONSTRUCTION

| PART | MATERIAL |
|-----------------------------|---|
| BODY | Stainless Steel - ASTM A276 - 316 SS |
| | Hastelloy - C276 |
| | Titanium - ASTM B348 |
| CAVITY PLATE | Stainless Steel - ASTM A276 - 316 SS |
| | Hastelloy - C276 |
| | Titanium - ASTM B348 |
| CAP | Stainless Steel - ASTM A276 - 316 SS |
| | Hastelloy - C276 |
| | Titanium - ASTM B348 |
| GEARS & BEARINGS | PPS - 30% Carbon / 15% PTFE |
| | PEEK - 15% Carbon |
| | PTFE |
| O-RINGS | Viton |
| | Teflon (PTFE) |
| | Buna-N |
| | EPR |
| SHAFT | Stainless Steel - ASTM A276 - 316 SS |
| | Hastelloy - C276 |
| | Titanium - ASTM B348 |
| MAGNET | Ceramic Encapsulated in PPS |
| | Ceramic Encapsulated in PEEK |
| | Samarium Cobalt Encapsulated in PPS |
| | Samarium Cobalt Encapsulated in PEEK |
| | Samarium Cobalt Weld Encapsulated and Molded Over with PPS |
| | Samarium Cobalt Weld Encapsulated and Molded Over with PEEK |
| MAGNET CUP | Stainless Steel - ASTM A167 |
| | Hastelloy - C276 |
| | Titanium - ASTM B265 |
| MAGNET SHROUD | Stainless Steel - AMS 5524 |
| | Hastelloy - C276 |
| | Titanium - ASTM B265 |

D SERIES PUMP NPIP_r DATA (PSI_a)

| PUMP SIZE | INLET PORT SIZE | 1000 RPM | 2000 RPM | 3000 RPM | 4000 RPM | 5000 RPM |
|-----------|-----------------|----------|----------|----------|----------|----------|
| .11 | 1/8" NPT | 0.05 | 0.08 | 0.10 | 0.13 | 0.20 |
| .19 | 1/8" NPT | 0.10 | 0.13 | 0.26 | 0.32 | 0.53 |
| .23 | 1/8" NPT | 0.12 | 0.15 | 0.28 | 0.40 | 0.56 |
| .38 | 1/8" NPT | 0.18 | 0.25 | 0.43 | 0.90 | 1.10 |
| .57 | 1/8" NPT | 0.20 | 0.30 | 0.55 | 1.00 | 1.30 |
| .68 | 1/8" NPT | 0.25 | 0.35 | 0.60 | 1.10 | 1.54 |
| .80 | 1/8" NPT | 0.34 | 0.68 | 1.40 | 2.20 | 4.00 |
| .11 | 1/4" NPT | 0.03 | 0.06 | 0.10 | 0.13 | 0.19 |
| .19 | 1/4" NPT | 0.08 | 0.10 | 0.20 | 0.30 | 0.50 |
| .23 | 1/4" NPT | 0.09 | 0.11 | 0.24 | 0.33 | 0.55 |
| .38 | 1/4" NPT | 0.15 | 0.23 | 0.40 | 0.70 | 0.91 |
| .57 | 1/4" NPT | 0.18 | 0.28 | 0.50 | 0.80 | 1.10 |
| .68 | 1/4" NPT | 0.20 | 0.30 | 0.66 | 0.85 | 1.30 |
| .80 | 1/4" NPT | 0.25 | 0.35 | 0.70 | 1.00 | 1.80 |
| .99 | 1/4" NPT | 0.30 | 0.40 | 0.75 | 1.10 | 1.90 |
| 1.2 | 1/4" NPT | 0.35 | 0.45 | 0.80 | 1.30 | 2.60 |
| 1.6 | 1/4" NPT | 0.40 | 0.50 | 1.10 | 1.80 | N/A |
| 2.0 | 1/4" NPT | 0.47 | 0.57 | 1.50 | 2.50 | N/A |
| 2.3 | 1/4" NPT | 0.55 | 0.64 | 2.00 | 3.20 | N/A |

T SERIES PUMP NPIP_r DATA (PSI_a)

| PUMP SIZE | INLET PORT SIZE | 1000 RPM | 2000 RPM | 3000 RPM | 4000 RPM |
|-----------|-----------------|----------|----------|----------|----------|
| 2.6 | 3/8" NPT | 0.50 | 1.50 | 3.10 | 5.60 |
| 5.3 | 3/8" NPT | 0.53 | 1.60 | 3.40 | 5.90 |
| 7.9 | 3/8" NPT | 1.00 | 1.90 | 3.80 | 6.10 |
| 8.0 | 3/4" NPT | 1.00 | 1.90 | 3.80 | 6.10 |
| 12. | 3/4" NPT | 1.50 | 2.40 | 4.20 | 6.30 |

NOTE: D & T are at 1 Cp Viscosity

REGULATORY COMPLIANCE INFORMATION



The D & T Series pumps' technical file is lodged in accordance with Article 13(1)(b)(ii) of ATEX Directive 2014/34/EU of 26 February 2014

THE FOLLOWING STANDARDS WERE USED TO VERIFY CONFORMANCE:

2006/42/EC – The Machinery Directive

EN 1127-1:2011 – Explosive atmospheres - Explosion prevention and protection - Part 1: Basic concepts and methodology

EN ISO 80079-36:2016 – Explosive atmospheres - Part 36: Non-electrical equipment for explosive atmospheres - Basic method and requirements

EN ISO 80079-37:2016 – Explosive atmospheres - Part 37: Non-electrical equipment for explosive atmospheres - Nonelectrical type of protection constructional safety "c", control of ignition sources "b", liquid immersion "k"



The D & T Series pumps comply with the European Directive 2006/42/EC

THE FOLLOWING STANDARDS WERE USED TO VERIFY CONFORMANCE:

EN ISO 12100:2010 – Safety of machinery - General principles for design

EN 809:1998+A1:2009 – Pumps and pump units for liquids - Common safety requirements

2011/65/EU – The Restriction of Hazardous Substances Directive

Ingersoll Rand

12500 South Pulaski Road
Alsip, Illinois 60803 USA
P: 708.389.2500
www.ingersollrand.com/pumps

Birkdale Close
Manners Industrial Estate
Ilkeston, Derbyshire DE7 8YA UK
P: 44.0.115.932.5226
www.ingersollrand.com/pumps

