



HD Engineering Data Pack

Contents:

Industrial Duty Pump Mounting Dimensions

Page 2:	Pump Mounting Dimensions (70A with optional flanged ports)
Page 3:	Pump Mounting Dimensions (120A with optional flanged ports)
Page 4:	Pump Mounting Dimensions (330 with optional flanged ports)
Page 5:	Pump Mounting Dimensions (600 with optional flanged ports)

General Pump Information

Page 6:	Model Number System
Page 7:	Temperature Limits
Page 8:	Materials of Construction (Industrial Duty Models)
Page 9:	Seal Information
Page 10:	Industrial Duty Seal Chamber Dimensions
Page 11:	HD NPSHr Data
Page 12:	Priming Ability of HD Series Pumps
Page 13:	Maximum Speed Vs. Viscosity and Horsepower Multiplying Factor Vs. Viscosity
Page 14:	Model 70A & 120A Pump Impeller Chart
Page 15:	Model 330 & 600 Pump Impeller Chart
Page 16:	Model 70A Impeller and Timing Gear Chart
Page 17:	Model 120A Impeller and Timing Gear Chart
Page 18:	Model 330 Impeller and Timing Gear Chart
Page 19:	Model 600 Impeller and Timing Gear Chart
Page 20:	Abrasives and Slurry Information
Page 21:	Spherical Particle Size Data
Page 22-23:	Packing Style Arrangements
Page 24:	HD Maximum Overhung Load Calculation
Page 24:	HD Maximum Allowable Transmitted Torque on Pump Shafts
Page 25:	HD Nozzle Loading Data
Page 26:	HD Model Steam Jacket & General Ph Chart
Page 27:	HD Maximum Case, Differential, Discharge, and Suction Pressures
Page 28:	Flange Ratings (Cast Iron)
Page 29:	Flange Ratings (Stainless Steel)

70A Pump Mounting Dimensions

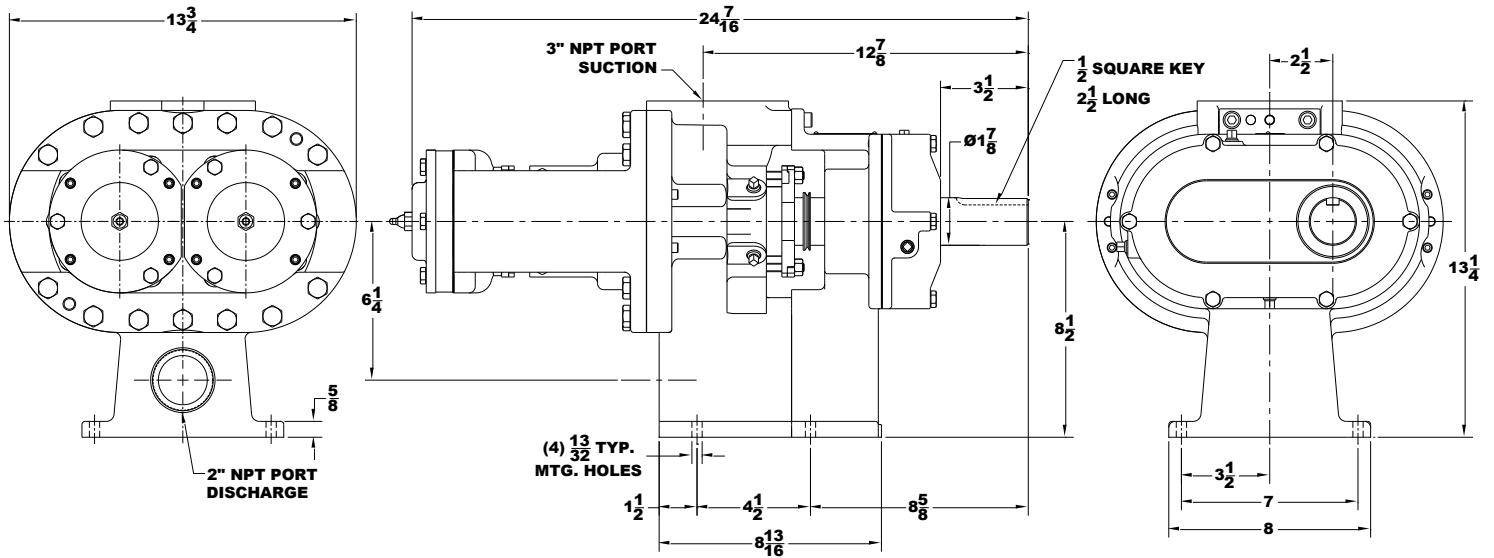

70A Pump Mounting Dimensions with Flanged Ports

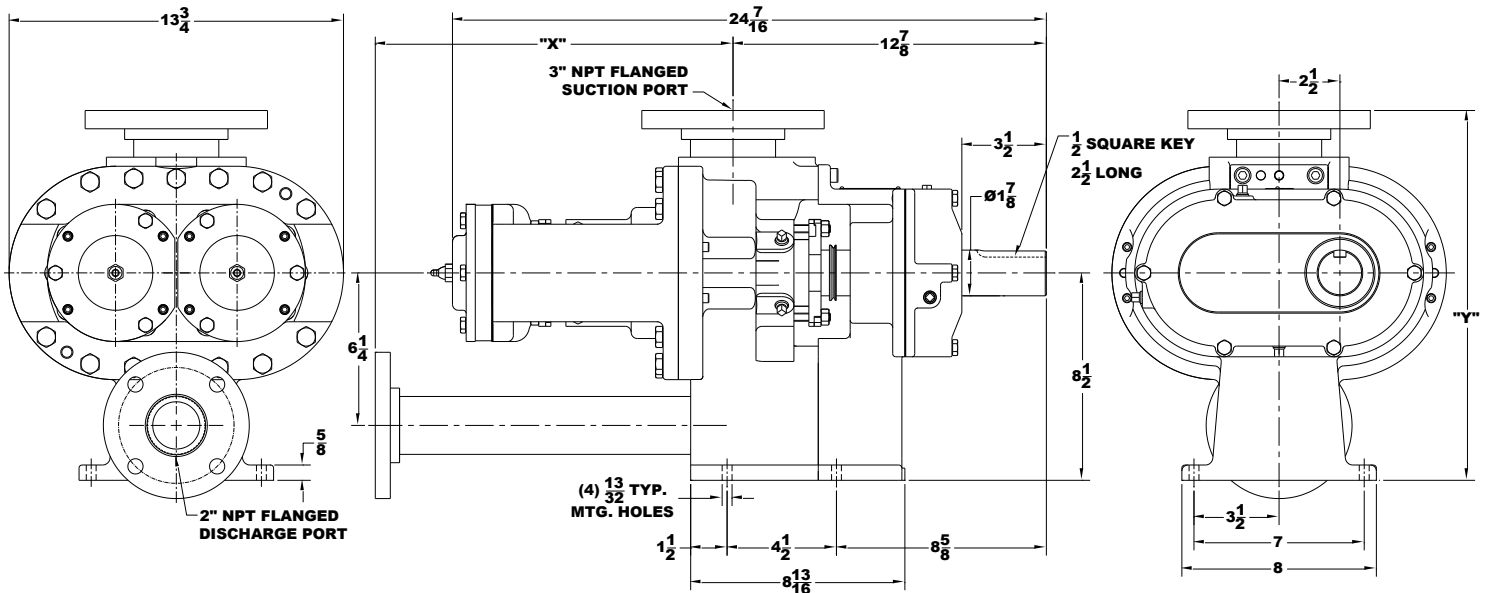

Flanged Port Dimensions ("X" & "Y" Dimensions)						
Size	Iron Pump			Stainless Steel Pump		
	CS ANSI 150# F.F.	CS ANSI 150# R.F.	CS ANSI 300# R.F.	SS ANSI 150# F.F.	SS ANSI 150# R.F.	SS ANSI 300# R.F.
"X"	$14\frac{23}{32} \pm \frac{1}{2}$ "	$14\frac{23}{32} \pm \frac{1}{2}$ "	$15\frac{1}{32} \pm \frac{1}{2}$ "	$14\frac{23}{32} \pm \frac{1}{2}$ "	$14\frac{23}{32} \pm \frac{1}{2}$ "	$15\frac{1}{32} \pm \frac{1}{2}$ "
"Y"	$15\frac{5}{32} \pm \frac{1}{2}$ "	$15\frac{5}{32} \pm \frac{1}{2}$ "	$15\frac{21}{32} \pm \frac{1}{2}$ "	$15\frac{5}{32} \pm \frac{1}{2}$ "	$15\frac{5}{32} \pm \frac{1}{2}$ "	$15\frac{21}{32} \pm \frac{1}{2}$ "

120A Pump Mounting Dimensions

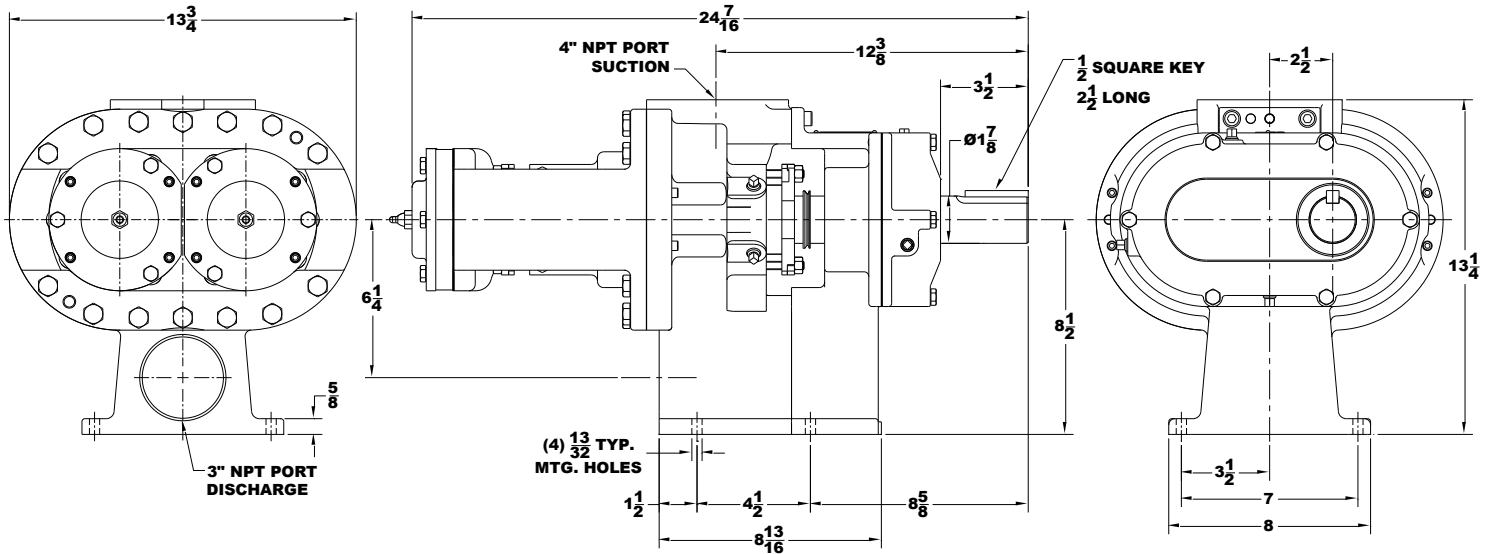

120A Pump Mounting Dimensions with Flanged Ports

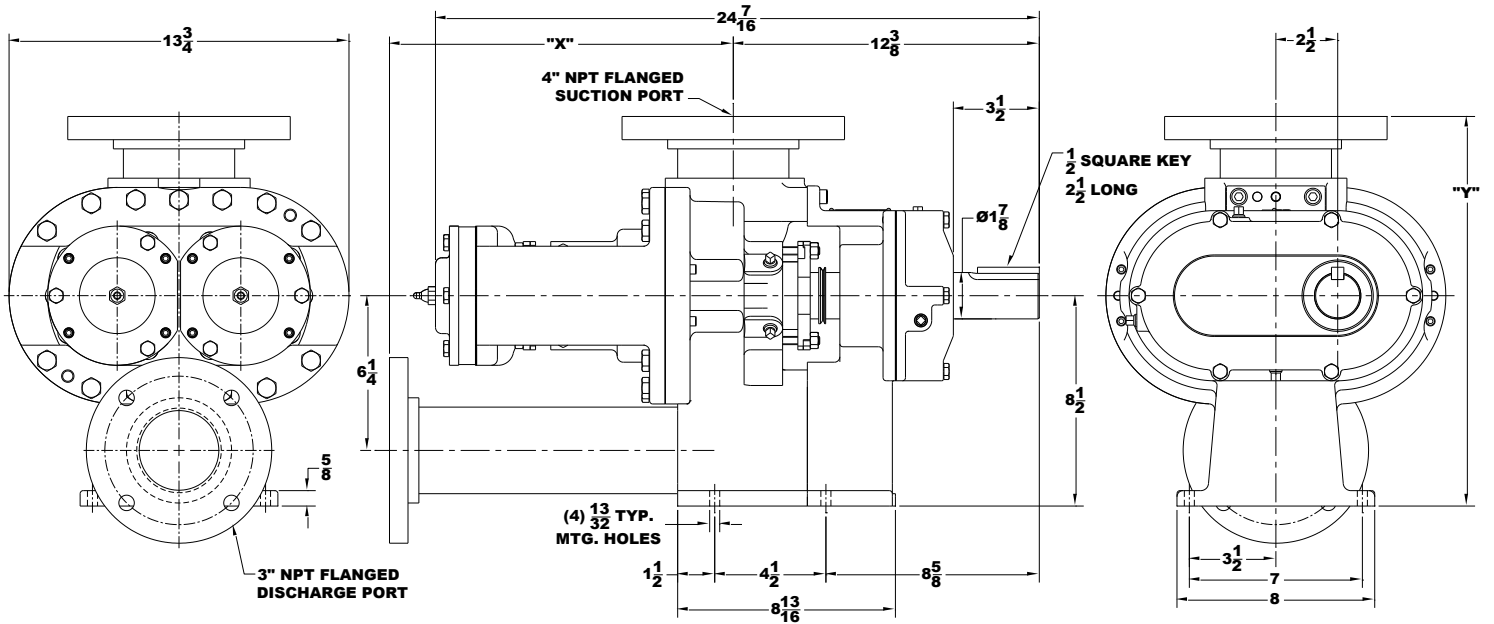

Flanged Port Dimensions ("X" & "Y" Dimensions)

Size	Iron Pump			Stainless Steel Pump		
	CS ANSI 150# F.F.	CS ANSI 150# R.F.	CS ANSI 300# R.F.	SS ANSI 150# F.F.	SS ANSI 150# R.F.	SS ANSI 300# R.F.
"X"	13 17/32" ± 1/2"	13 17/32" ± 1/2"	14 1/32" ± 1/2"	13 17/32" ± 1/2"	13 17/32" ± 1/2"	14 1/32" ± 1/2"
"Y"	15 3/8" ± 1/2"	15 3/8" ± 1/2"	15 3/4" ± 1/2"	15 3/8" ± 1/2"	15 3/8" ± 1/2"	15 3/4" ± 1/2"

330 Pump Mounting Dimensions

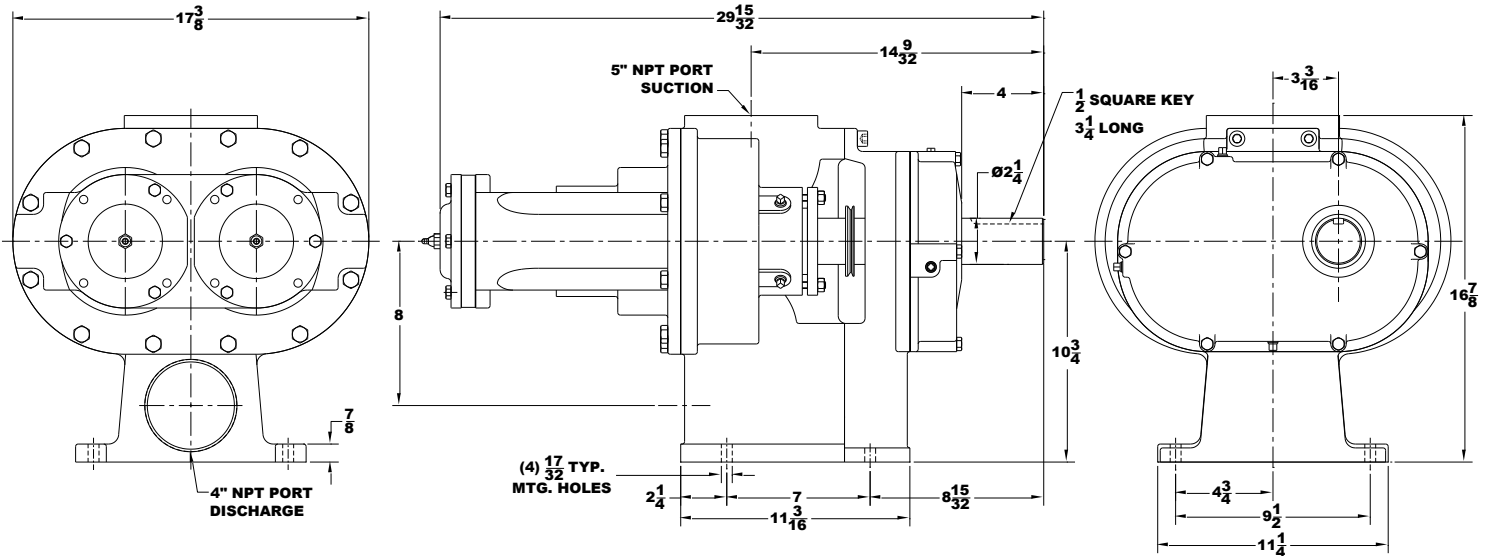

330 Pump Mounting Dimensions with Flanged Ports

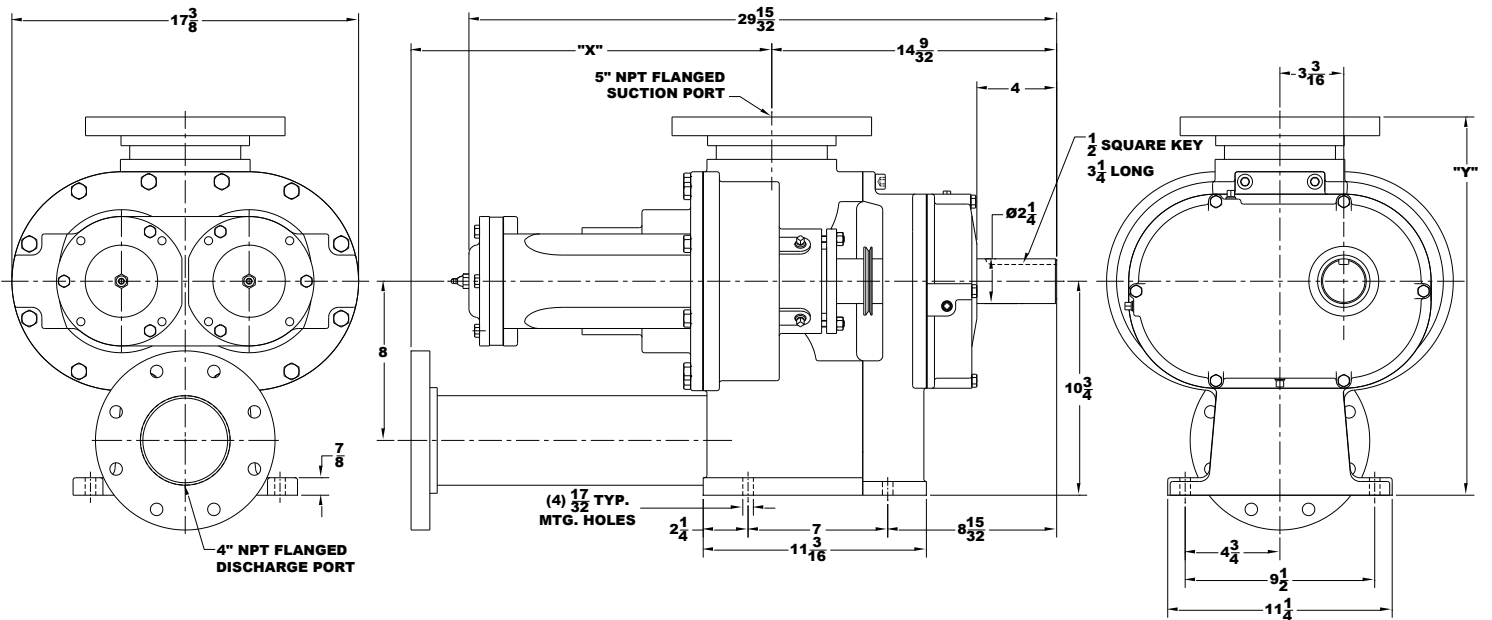

Flanged Port Dimensions ("X" & "Y" Dimensions)

Size	Iron Pump			Stainless Steel Pump		
	CS ANSI 150# F.F.	CS ANSI 150# R.F.	CS ANSI 300# R.F.	SS ANSI 150# F.F.	SS ANSI 150# R.F.	SS ANSI 300# R.F.
"X"	18 3/32" ± 1/2"	18 3/32" ± 1/2"	18 21/32" ± 1/2"	18 3/32" ± 1/2"	18 3/32" ± 1/2"	18 21/32" ± 1/2"
"Y"	19" ± 1/2"	19" ± 1/2"	19 9/16" ± 1/2"	19" ± 1/2"	19" ± 1/2"	19 9/16" ± 1/2"

600 Pump Mounting Dimensions

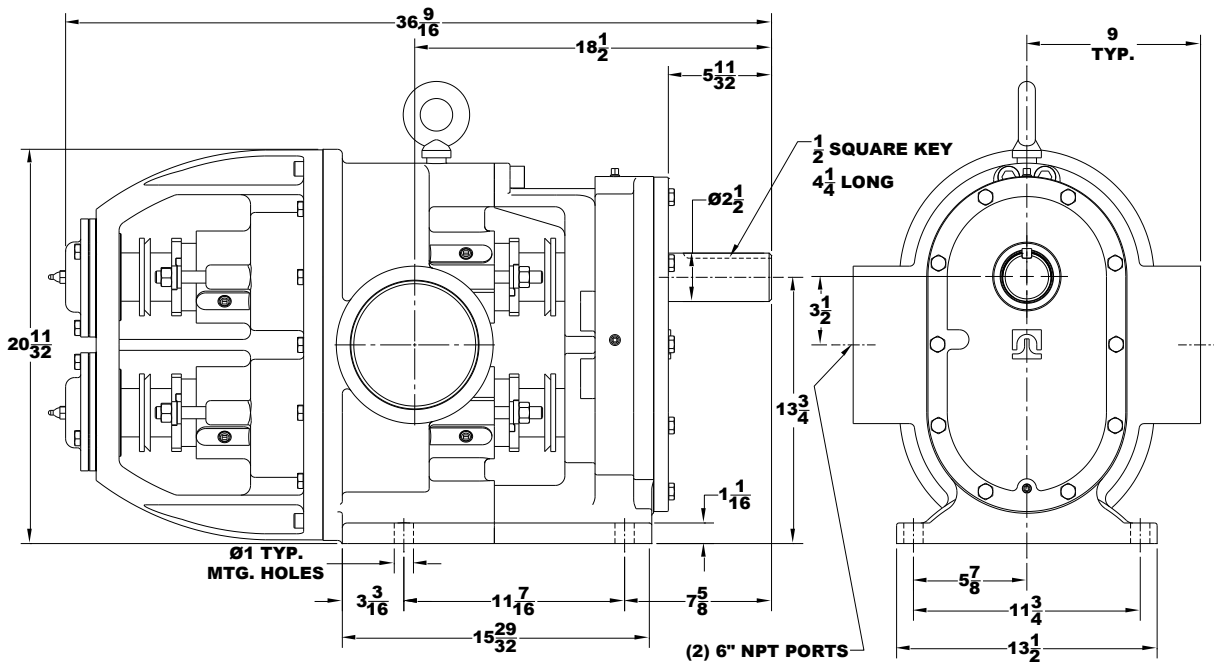

600 Pump Mounting Dimensions with Flanged Ports

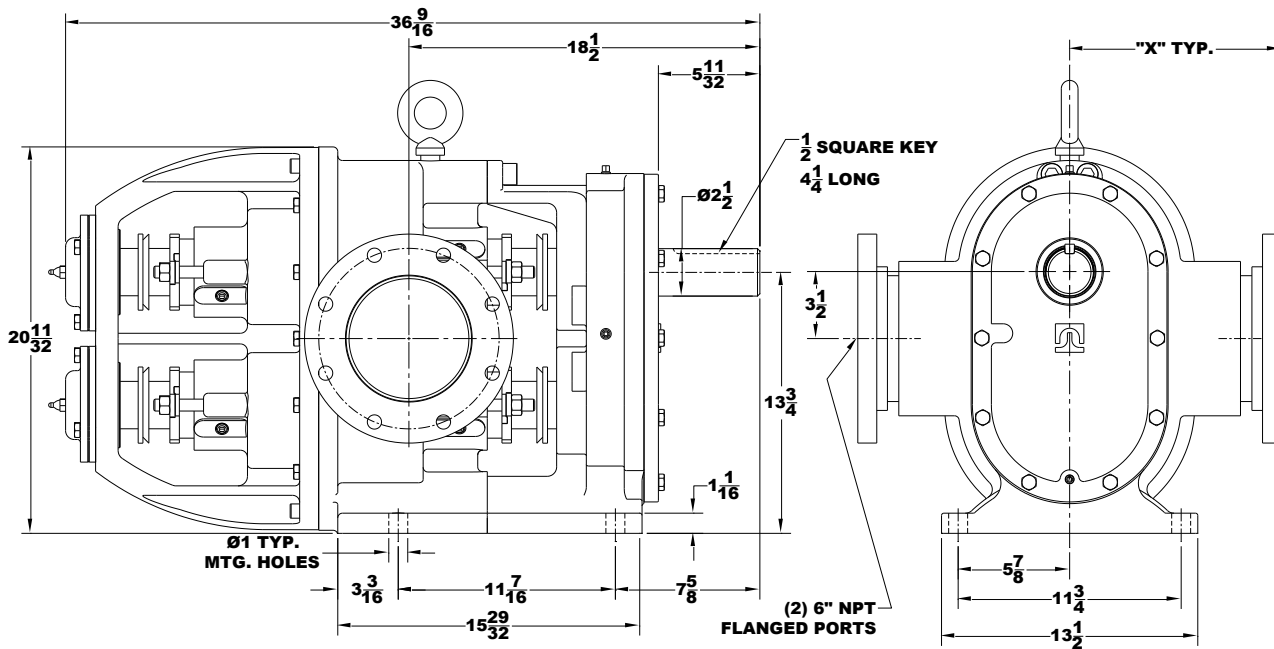

Flanged Port Dimensions ("X" & "Y" Dimensions)

Size	Iron Pump			Stainless Steel Pump		
	CS ANSI 150# F.F.	CS ANSI 150# R.F.	CS ANSI 300# R.F.	SS ANSI 150# F.F.	SS ANSI 150# R.F.	SS ANSI 300# R.F.
"X"	11 5/32" ± 1/2"	11 5/32" ± 1/2"	11 21/32" ± 1/2"	11 5/32" ± 1/2"	11 5/32" ± 1/2"	11 21/32" ± 1/2"

HD Process Pump Numbering System

1	2	3	4	5	6	7	8	9	10	11	12	13
---	---	---	---	---	---	---	---	---	----	----	----	----

<i>DIGITS 1 & 2</i>	O5-INDUSTRIAL DUTY (ID)
<i>DIGITS 3 & 4</i>	16 – Model 70A 31 – Model 120A 75 – Model 330 91 – Model 600
<i>DIGITS 5 & 6</i>	04 – 316 Stainless Steel 09 – Ductile Iron
<i>DIGIT 7</i>	0 – Internal NPT (Std. on ID models) 3 – Flanged Port Option
<i>DIGIT 8</i>	0 – No Relief Valve
<i>DIGITS 9 & 10</i>	01 – Hot Clearance 02 – Special Shaft Material 05 – Special Packing 06 – Special Packing Configuration 08 – Mechanical Seals 09 – Special Bushings 10 – Special Clearances 13 – Steam Jacket/Tracing 19 – Special Ports (Flanged, etc.) 21 – Tutriding 26 – Interference Fit Gears 27 – Special U-Cup/Lip Seals 28 – Miscellaneous
<i>DIGITS 11 & 12</i>	01, 02, Etc. (Serialized at the factory)
<i>DIGIT 13 (If Required)</i>	D – Double Lobe

Temperature Limits of HD Process Pump Materials

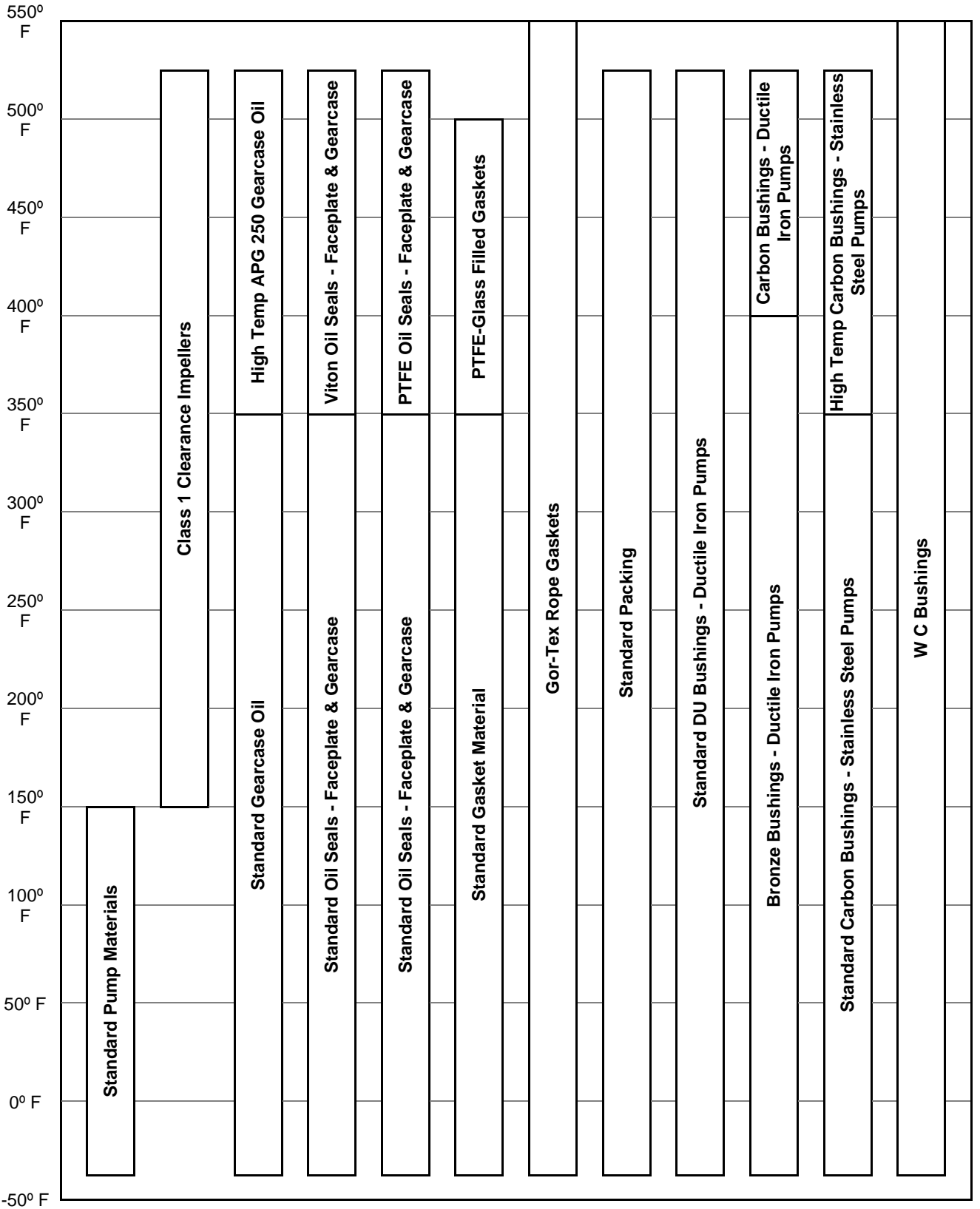

Note:

- Viton and PTFE oil seals can be used in place of standard oil seals upon request.
- PTFE and Gor-Tex gaskets can be used in place of standard seals upon request.

HD Industrial Duty Pump Materials of Construction

Part Name	Material	Standard	Comments	Availability	
				DI*	SS*
Impeller Housing	Ductile Iron	ASTM A536, grade 80-55-06	187-255 Brinell Hardness	S	
	Stainless Steel	ASTM A743, grade CF-8M	155-185 Brinell Hardness		S
	Tutrided Ductile Iron	ASTM A536, grade 80-55-06	Surface Hardened	O	
Faceplate	Ductile Iron	ASTM A536, grade 80-55-06	187-255 Brinell Hardness	S	
	Stainless Steel	ASTM A743, grade CF-8M	155-185 Brinell Hardness		S
	Tutrided Ductile Iron	ASTM A536, grade 80-55-06	Surface Hardened	O	
Gearcase	Cast Iron	ASTM A48		S	S
Gearcase Cover	Cast Iron	ASTM A48		S	S
Impellers	Ductile Iron	ASTM A536, grade 80-55-06		S	
	Stainless Steel	ASTM A743, grade CF-8M	155-185 Brinell Hardness		S
	Tutrided Ductile Iron	ASTM A536, grade 80-55-06	Surface Hardened	O	
Drive & Driven Shafts	High Strength Steel	ASTM A564, grade 630	Armco 17-4PH	S	S
	C.O. Coated High Strength Steel	ASTM A564, grade 630	Armco 17-4PH Chrome Oxide Coated	O	O
Housing Bushing	Carbon	Carbon Graphite Resin			S
	DU Bushing	Steel Backed / PTFE Coated		S	
Gearcase Ball Bearing	Steel			S	S
Faceplate Ball Bearing	Steel			S	S
Steam Jacket	Aluminum			O	O

* DI for Ductile Iron Pumps and SS for Stainless Steel Pumps.

* S = Standard, O = Optional

HD Seal Specifications

Packing

<i>Packing Description</i>	<i>Packing Style</i>	<i>Material Description</i>
Standard Packing (Graphite/PTFE)	ML4002 or ML8002	Braided PTFE with graphite impregnation
Pure PTFE Packing	ML2236FDA	Braided pure PTFE (FDA approved)
	ML2235	Braided pure PTFE (Not FDA approved)
Optional Lantern Ring (Style 2, 3 & 4 Packing)		PTFE
		303 Stainless Steel
Throttle Bushing (Style 4 Packing)		PTFE
		303 Stainless Steel

Mechanical Seal

<i>Seal Description</i>	<i>Seal Type</i>	<i>Material of Construction</i>			
		<i>Secondary Seal</i>	<i>Rotating Face</i>	<i>Stationary Face</i>	<i>Hardware</i>
Single PTFE Mechanical Seal	9T	PTFE	Carbon	Ceramic	316 S.S.
Single Abrasion Resistant Mechanical Seal	82	Viton	Tungsten Carbide	Silicon Carbide	316 S.S.
Double PTFE Mechanical Seal	9T	PTFE	Carbon	Ceramic	316 S.S.
Double Abrasion Resistant Mechanical Seal	82	PTFE	Tungsten Carbide	Silicon Carbide	316 S.S.

Cartridge Seal

<i>Seal Description</i>	<i>Seal Type</i>	<i>Material of Construction</i>			
		<i>Secondary Seal</i>	<i>Lips</i>	<i>Gasket</i>	<i>Hardware</i>
Double Lip Cartridge Seal	44	Viton	PTFE	Gylon	316 S.S.
Triple Lip Cartridge Seal	42	Viton	PTFE	Gylon	316 S.S.

- 1.) Tuthill can supply a variety of seals with different material combinations to suit specific application requirements. The above list displays the most common/standard seal combinations used
- 2.) Viton® - Registered trademark of E.I. DuPont De Nemours & Company
Gylon® - Registered trademark of Garlock, Inc.

Industrial Duty Seal Chamber Dimensions

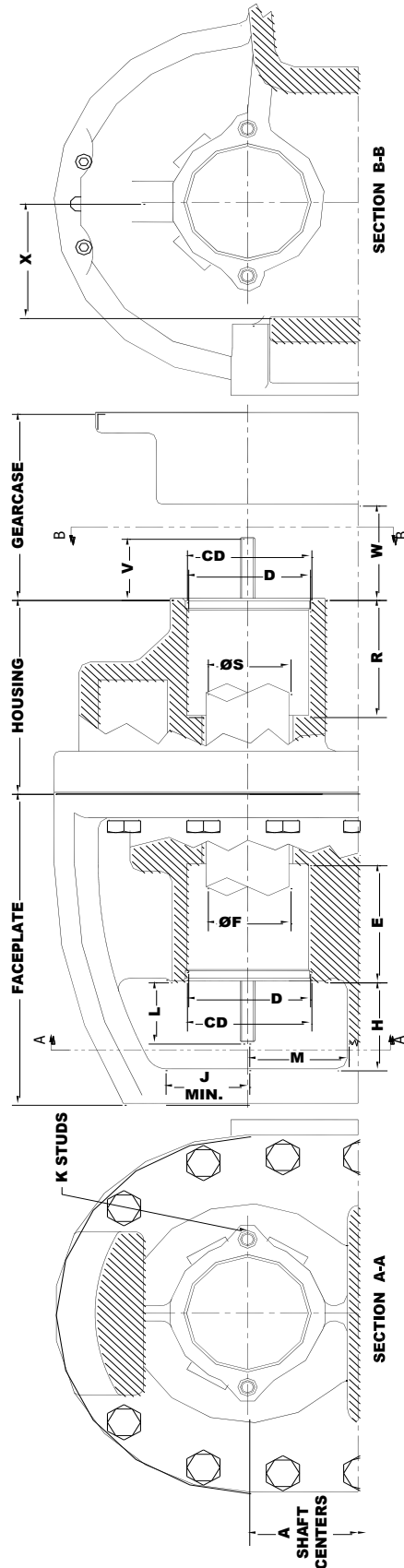

MODEL	"A"	"B"	"D"	"E"	"F"	"CD"	"H"		"J"		"L"		"M"		"K STUDS" QTY.	"R"	"S"	"V"		"X" MIN.
							S.S.	D.I.	S.S.	D.I.	S.S.	D.I.	S.S.	D.I.				S.S.	D.I.	
30A	2.5005	3	1.504	1 5/8	1.567	.9985	2	2	13/16	13/16	1 7/16	1 7/16	NO CENTER RIB	8	1 5/8	1.000	1 7/16	1 7/16	3	1 3/32
	2.4995		1.498		1.560	.9980										.9995			2 5/16	1 3/16
2A	4.0005	3 1/2	1.878	2 1/8	2.067	1.374	2 1/16	1 1/2	1 1/2	1 1/2	1 7/16	1 1/2	1 25/32	8	2 1/8	1.3750	1 1/2	1 1/2	2 5/8	2 9/16
	3.9995		1.873		2.060	1.373							1 32/32			1.3745				
3A	4.0005	3 1/2	1.878	2 1/8	2.067	1.374	2 1/16	1 1/2	1 1/2	1 1/2	1 7/16	1 1/2	1 25/32	8	2 1/8	1.3750	1 1/2	1 1/2	2 5/8	2 9/16
	3.9995		1.873		2.060	1.373							1 32/32			1.3745				
70A	5.0005	5 3/8	2.758	2 7/8	NONE	1.869	3 2/8	11 32/32	2 3/16	2 3/16	1 1/2	1 1/2	1 15/64	8	3 5/8	1.8745	1 1/2	1 1/2	2 5/8	3
	4.9995		2.752			1.868							2 64/64			1.8740				
120A	5.0005	5 3/8	2.758	2 7/8	NONE	1.869	3 11/32	2 3/16	2 3/16	1 1/2	1 1/2	1 15/64	8	3 5/8	1.8745	1 1/2	1 1/2	2 5/8	3	
	4.9995		2.752			1.868							2 64/64			1.8740				
330	6.4005	4 1/4	3.255	3 5/16	NONE	2.244	3 1/8	3 7/32	2 1/2	2 1/2	2	2	1 15/64	8	5 5/16	2.2488	2	2	3 1/16	3 5/8
	6.3995		3.250			2.243							2 64/64			2.2480				
600	7.0005	6 3/4	3.510	3 1/4	NONE	2.494	4 1/16	3 7/8	2 3/4	2 3/4	2 3/16	2 3/16	1 3/4	8	5 1/8	2.4988	2	2	3 3/4	3 3/8
	6.9995		3.505			2.493							3 32/32			2.4980				

HD NPSHr Data

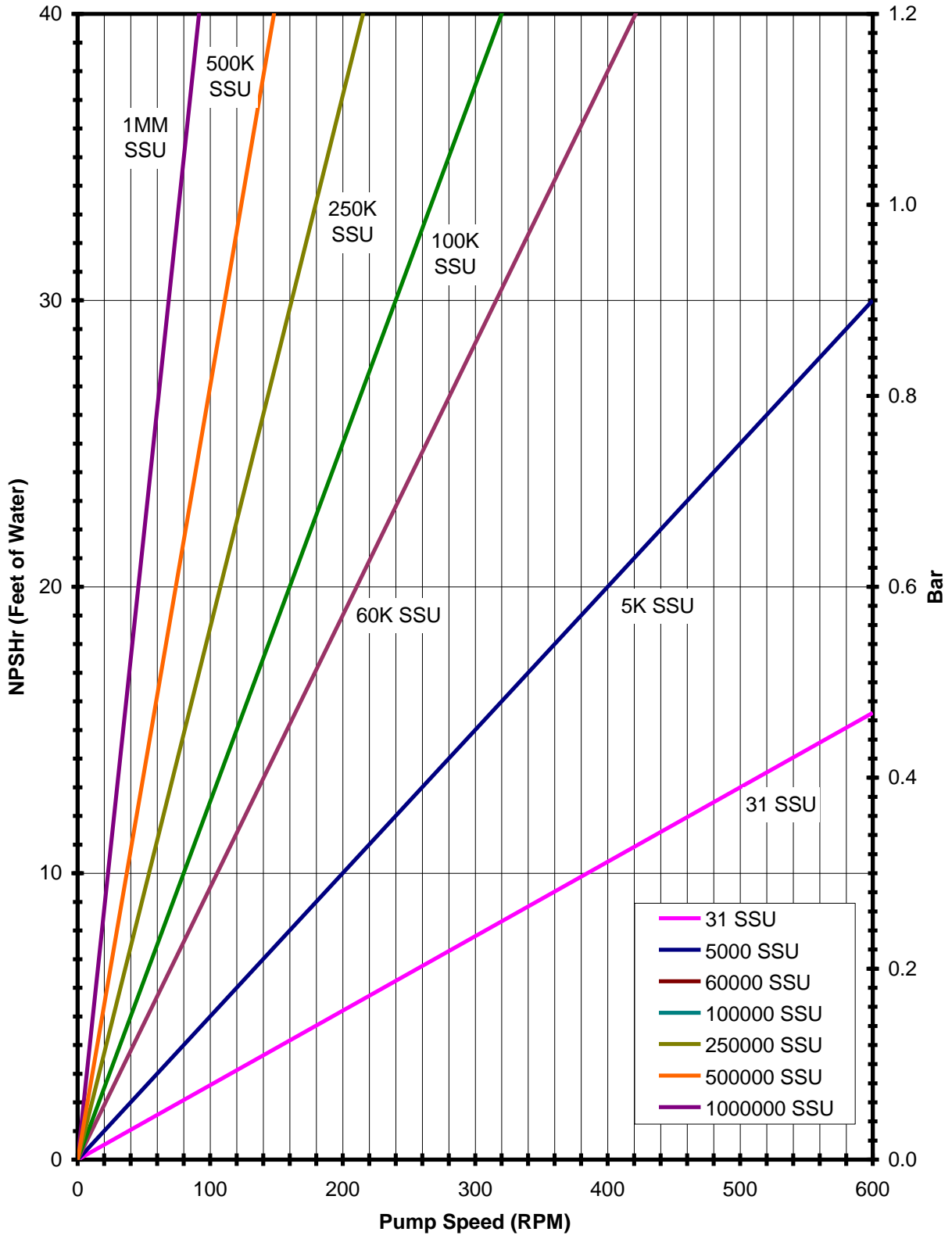

Priming Ability of HD Series Pumps

Performance curves indicating priming ability of pumps based on test data obtained on new pumps. Priming ability of older pumps, because of larger clearances, will not be as good.

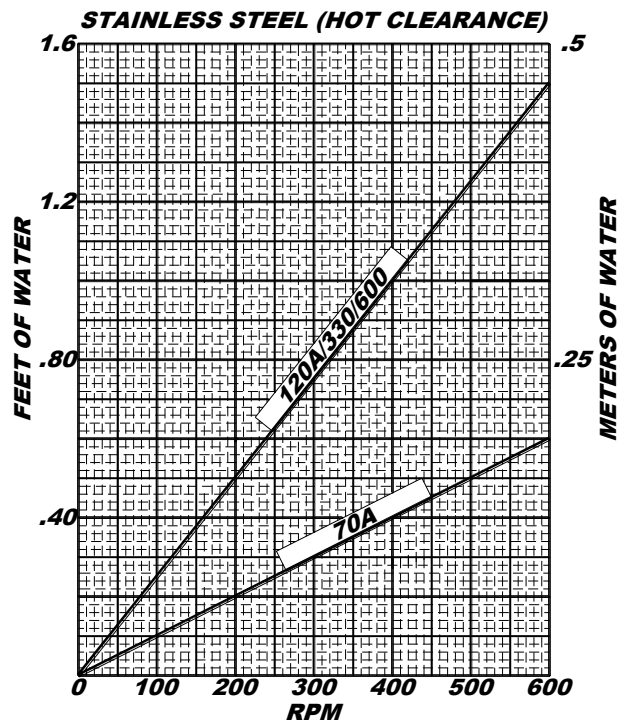
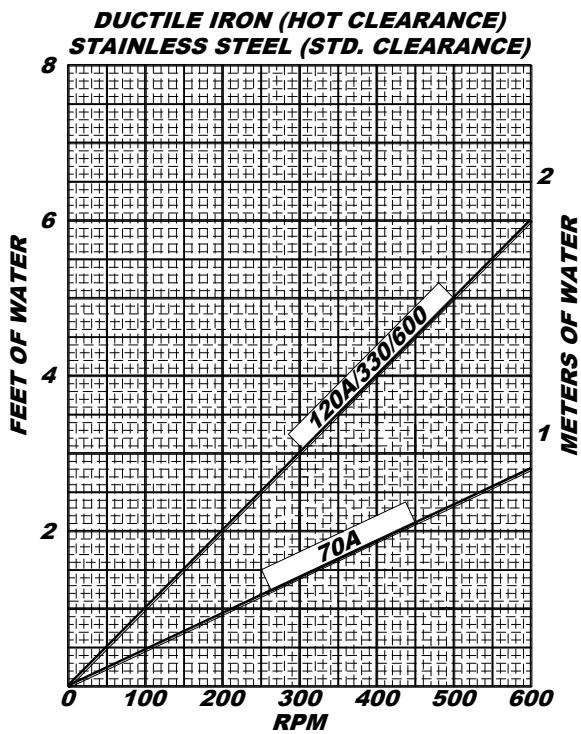
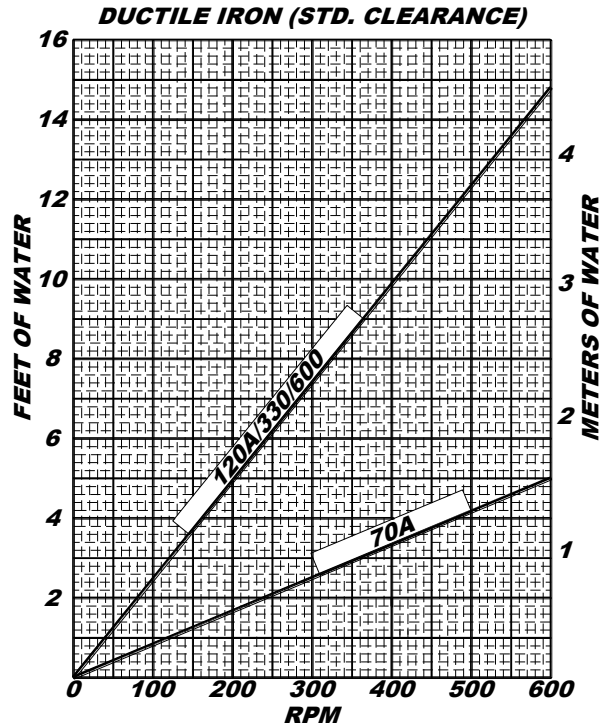

Maximum Speed Vs. Viscosity

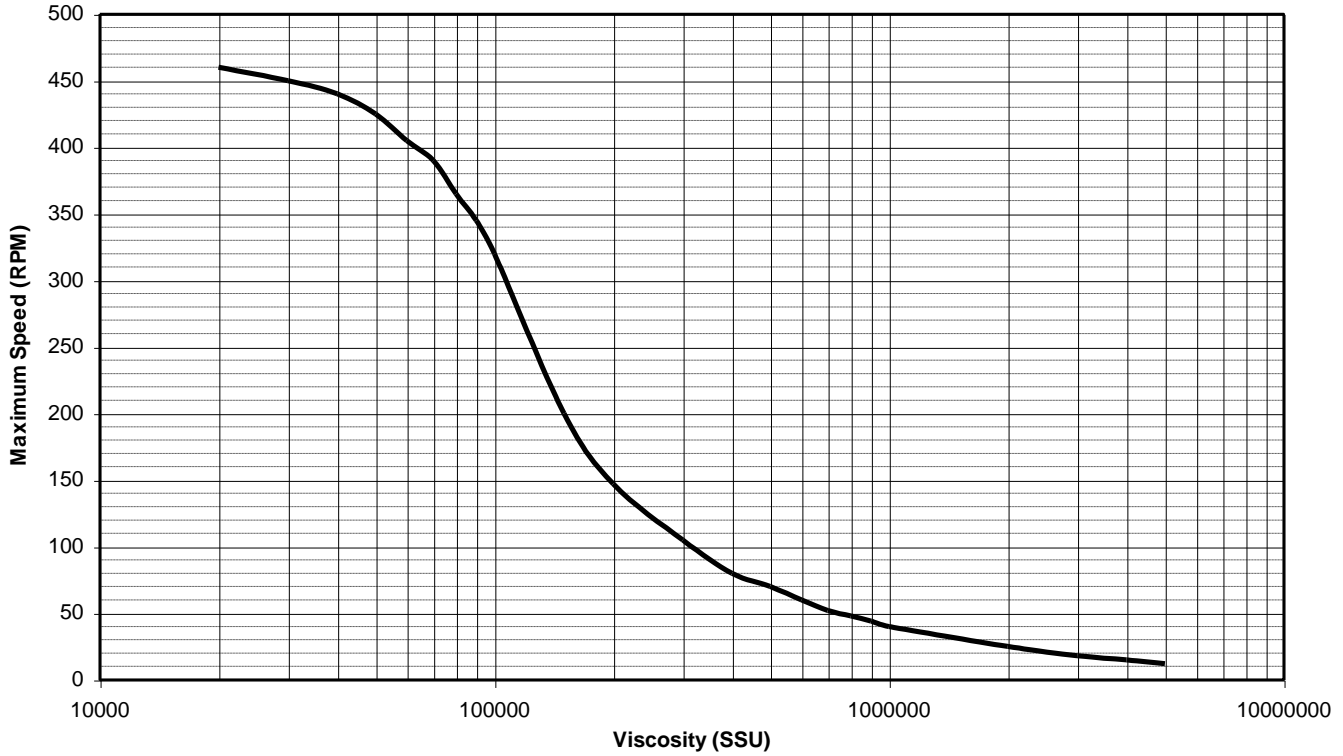

Horsepower Multiplying Factor Vs. Viscosity

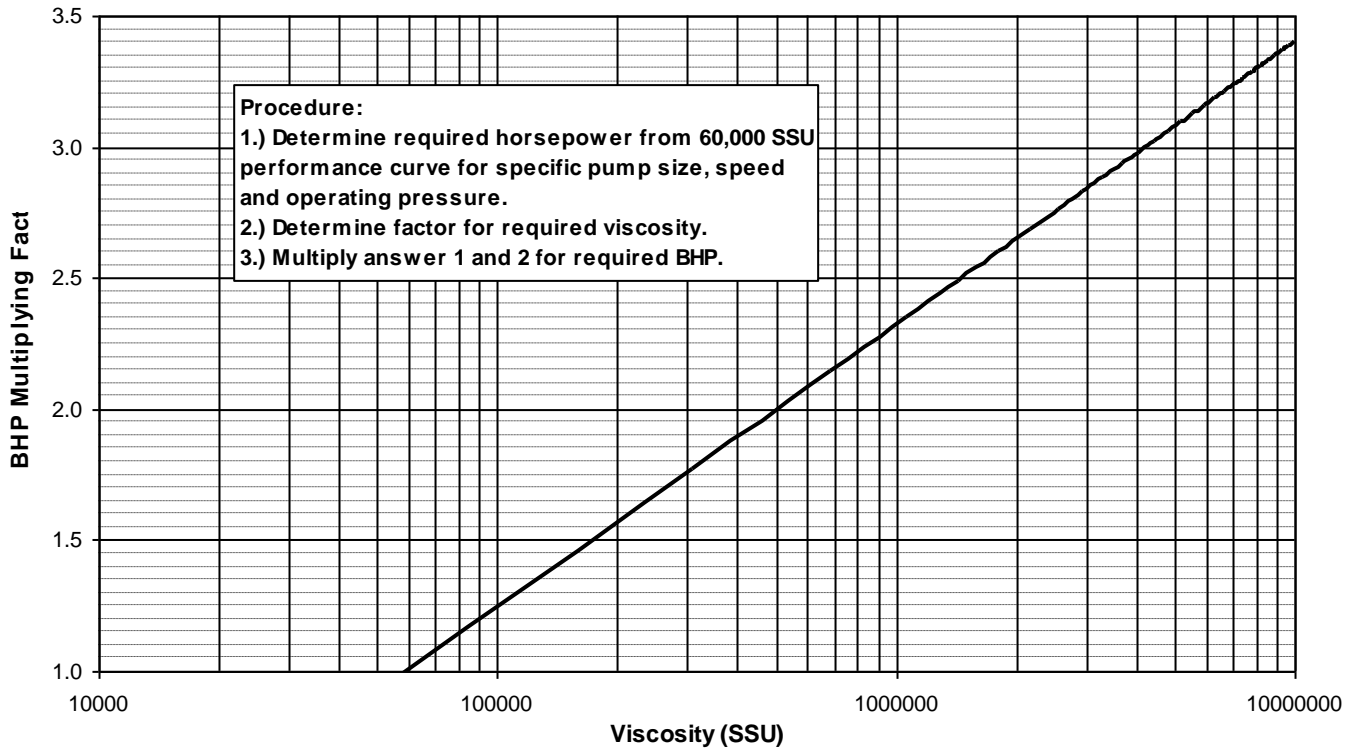

Model 70A Pump Impeller Chart

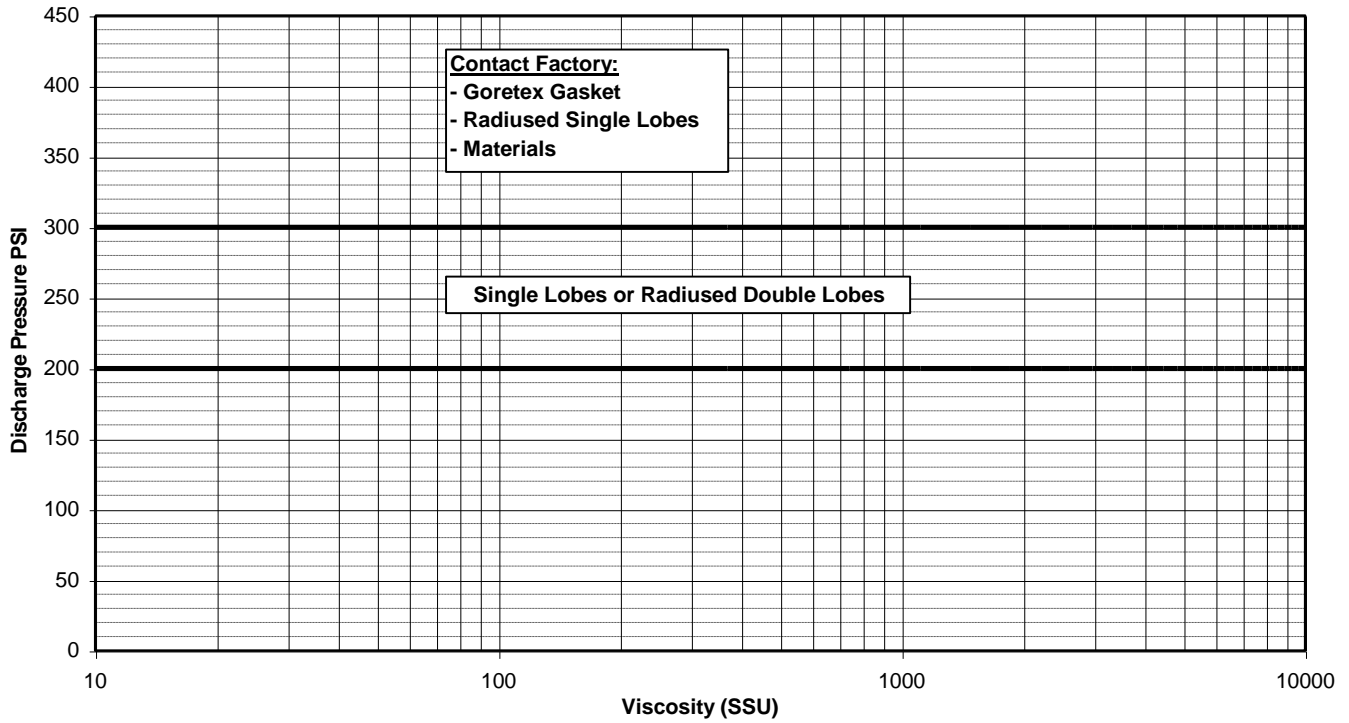

Model 120A Pump Impeller Chart

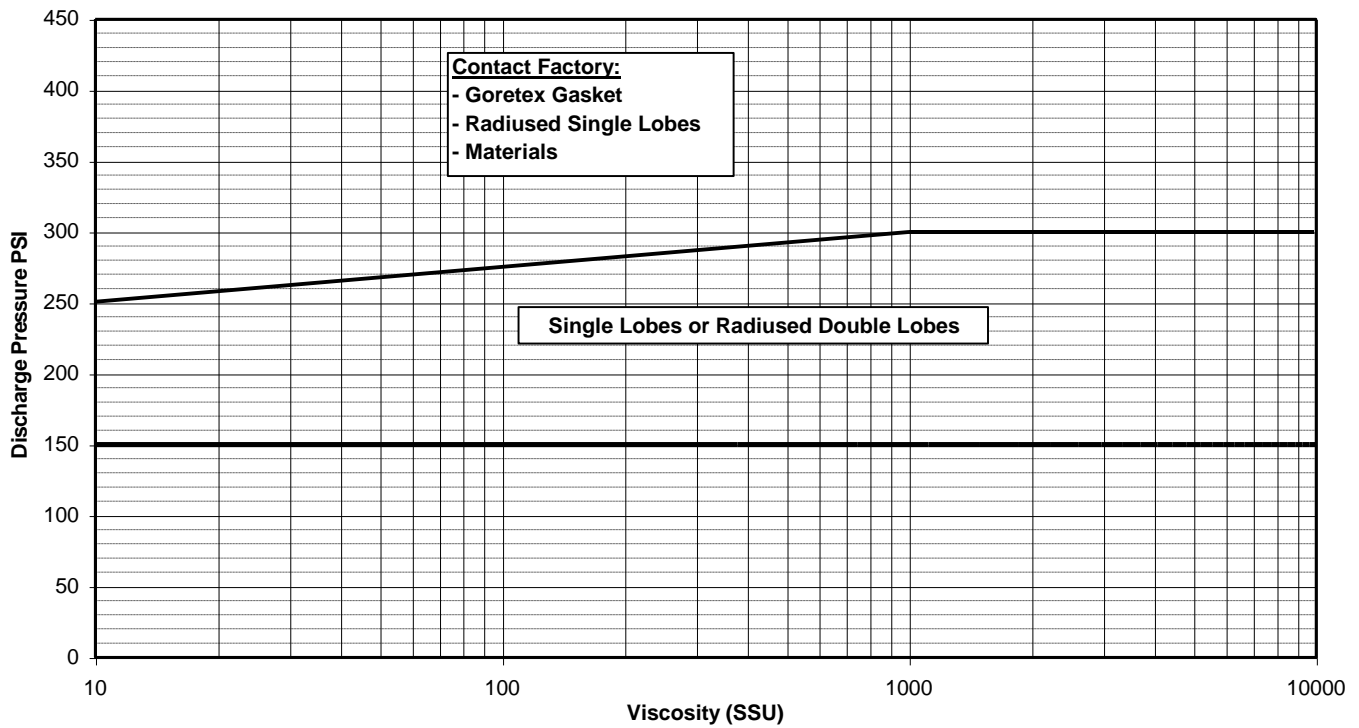

Model 330 Pump Impeller Chart

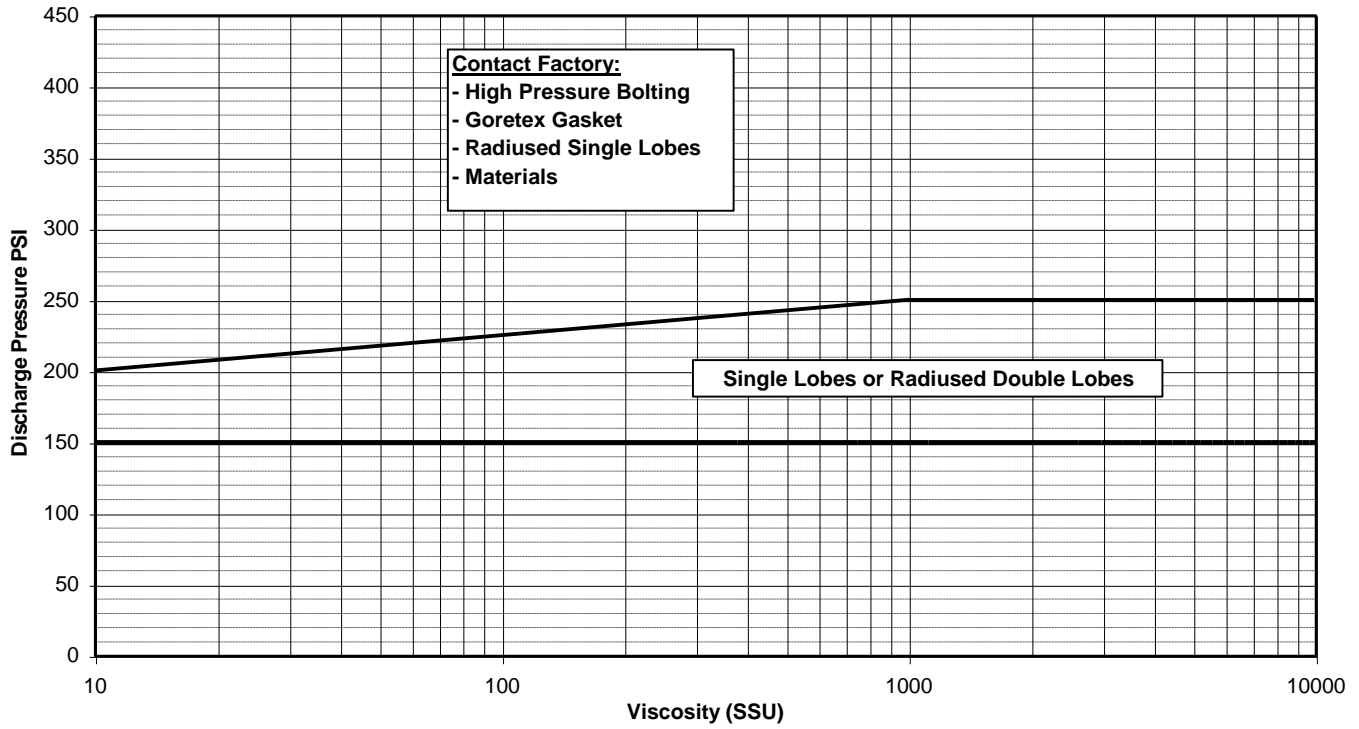

Model 600 Pump Impeller Chart

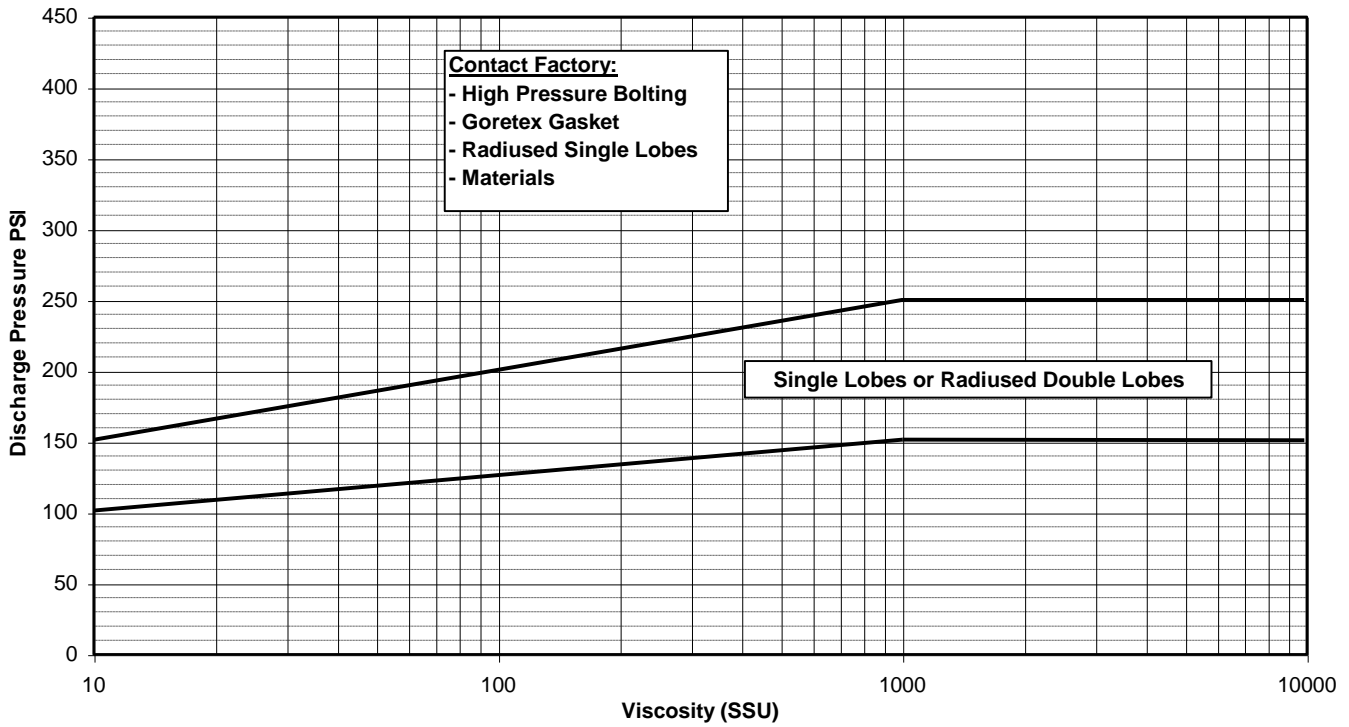

Model 70A Impeller and Timing Gear Chart

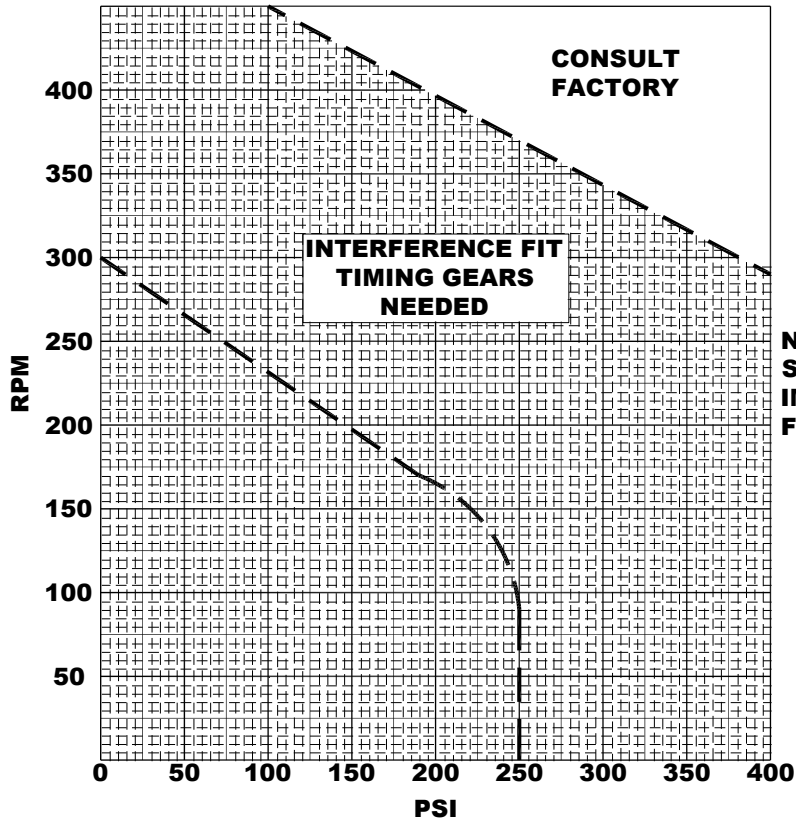

NOTE:
SINGLE OR DOUBLE LOBE
IMPELLERS ARE SATISFACTORY
FOR FULL RANGE SHOWN

Model 120A Impeller and Timing Gear Chart

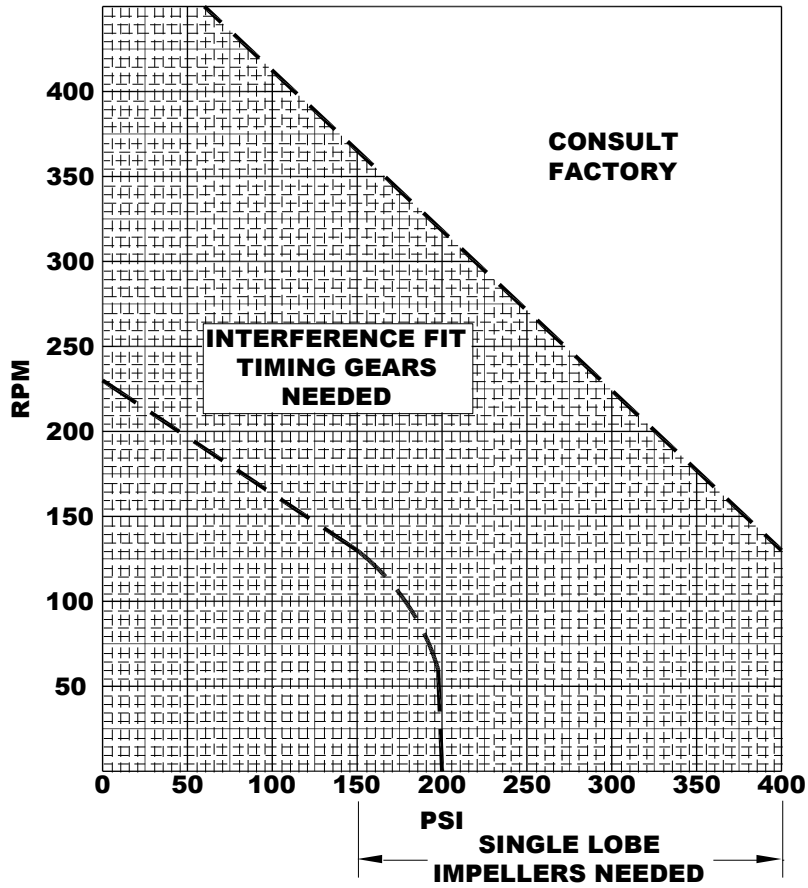

Model 330 Impeller and Timing Gear Chart

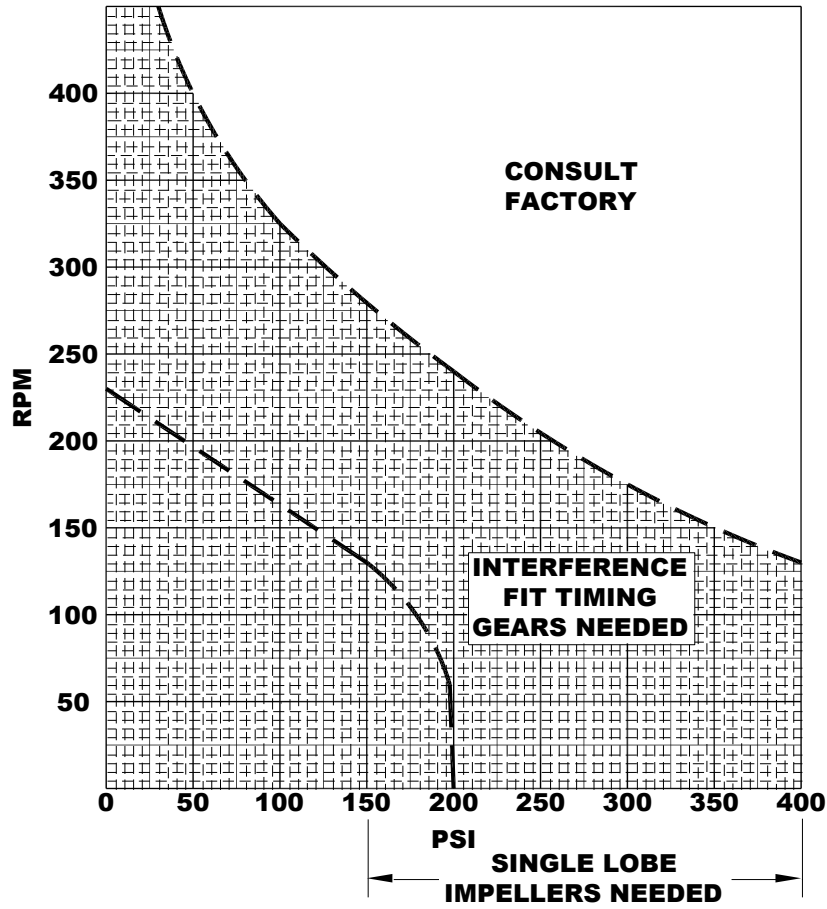

Model 600 Impeller and Timing Gear Chart

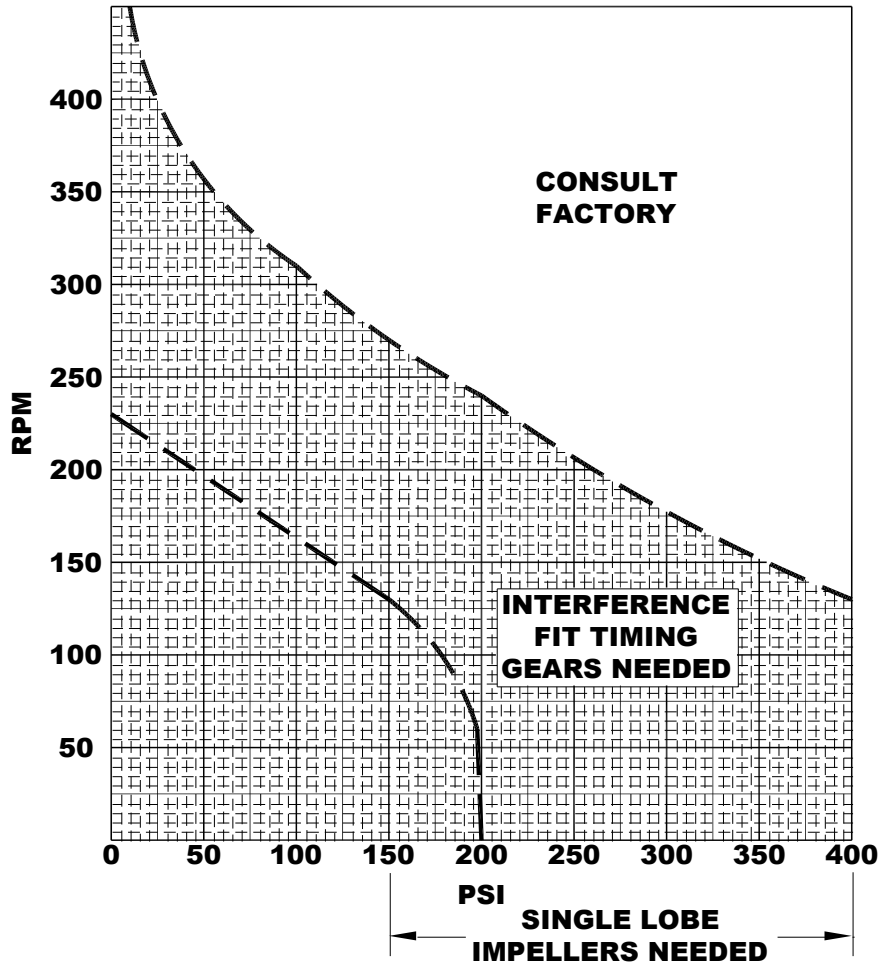

Abrasives & Slurries

The Tuthill process pump is ideally suited for slurries, since it is capable of handling a wide range of apparent viscosities and solid particle sizes. When sizing a process pump, you must determine the viscosity of the carrier fluid, particle size, and particle hardness.

The thicker the carrier fluid, the less recirculation of product through the fluid chamber clearances (slip), thus there is less erosive wear from any abrasive particle. If the carrier fluid is water thin, the abrasive particles are allowed to re-circulate in the clearances, resulting in a short wear life.

Particle size and hardness both affect the wear life of a process pump. Each process pump model has different clearance dimensions. If the particle is harder than the pump material construction and larger than the clearance dimension, the pump will generally have initial wear equal to that of the particle size and level off to a slower, constant wear rate. If the particle size is smaller than the pump clearances, the wear is less of a problem. A particle is therefore defined as abrasive if it is equal to or harder than the pump construction and larger than the factory set clearances in a new pump.

Knowing that the process pump has been successfully applied on abrasive slurries, we generally do not recommend pump speeds on inorganic slurries to be any greater than 190 RPM. Try to maintain slowest possible speeds for any abrasive slurry. Wear life is relative; the Tuthill process pump will always do better than gear or vane pump at identical operating speeds.

The following are maximum recommended pump speeds for existing applications:

Waste solvents, oil, paints, etc:	230 RPM
Municipal sludge/scum:	190 RPM
Animal rendering:	100 RPM
Asphalt with filler:	100 RPM
Magnetic oxide slurries:	150 RPM
Grain slurries (mash):	150 RPM
Clay coatings slurries:	280 RPM
Clay slip & ceramic slurries:	50 RPM
Coal oil surface:	190 RPM

Spherical Particle Size Data

The chart below shows the theoretical maximum, and recommended maximum particle size that a pump will pass. This is strictly a function of geometry. Pumps will last longer if abrasive particles are smaller than internal pump clearances and softer than the internal pump parts. On slurries with maximum diameter particles, 100-RPM maximum speed is recommended to minimize crushing. Particles must be able to be sheared by pump impellers or the pump will stall.

Pump Model	Theoretical Maximum Diameter (inches)	Recommended Maximum Diameter (inches)
70A	1.250	.750
120A	1.500	.875
330	2.250	1.000
600	3.000	1.250

Particle Size Reference

Mesh	Micron	Inches
400	37	.0015
200	74	.0029
100	149	.0059
50	297	.0117
20	841	.0331
10	2000	.0787
3	6730	.2650

Packing Style Arrangements

Style #1

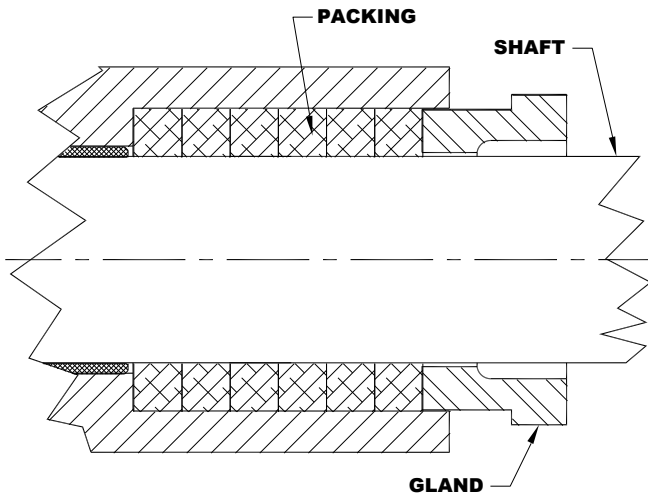

Available Options:

- Packing: Pure PTFE, Graphite, other special materials available on request.
- Shaft: Steel, Armco 17-4PH, 316 S.S. (all have ceramic coating option).
- Style #1 packing is the standard for all HD models.

Style #2 (Lantern Ring)

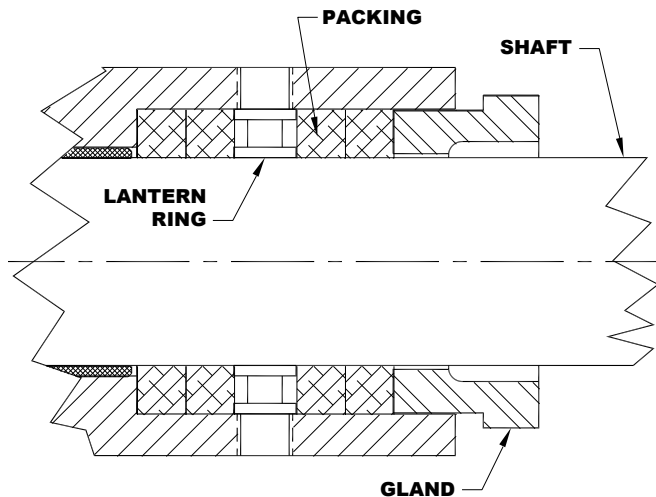

Recommended Usage:

- Grease lubrication improves sealing and packing life.
- Vent to suction side of pump to reduce pressure on outboard packing.
- Flush with clean fluid at 15-20 PSI above pump discharge pressure. Some product dilution will occur so compatible fluid must be used.

This design is the same as Style #1 except lantern ring and "in" and "out" flush connections are provided in the approximate location shown. A minimum of two rings of packing will be installed inboard to throttle flow. Standard lantern ring material is glass filled PTFE. Rings may be made in other materials as required. All available options from Style #1 apply.

Style #3 (Clay Coating)

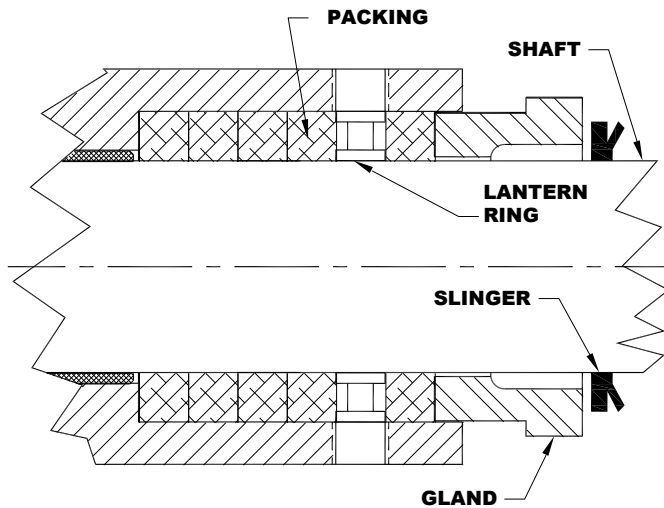

Design Requirements:

- Special location of "in" connection.
- Add lantern ring.
- Shaft and packing material options available.
- Use of slingers is recommended.

This design was introduced specifically for the paper industry to seal clay coatings, but can be used on like products. To function properly it requires a low pressure (5-10 PSI) water flush outboard. Flush will keep clay from drying, at which point it becomes abrasive, and the low pressure will not dilute the product. Slingers are provided to keep water from running down the shaft and entering bearings.

Style #4 (Mill Sludge)

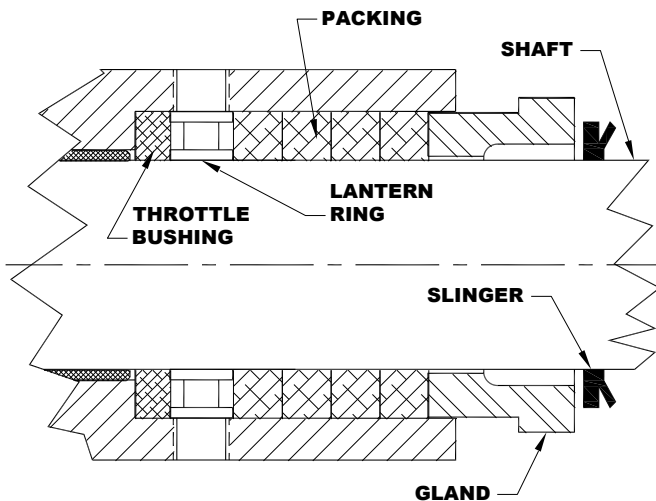

Design Requirements:

- Special location of "in" connection.
- Add lantern ring.
- Add throttle bushing.
- Shaft and packing material options available.
- Use of slingers is recommended.

This design serves two distinct sealing functions. The first application is flushing clean product "in". To be effective flushing fluid must be 20-30 PSI in excess of pump discharge pressure. This design was employed successfully on mill sludge with consistency of 4-10% solids, including paper fibers (up to 90% of solids). This method of flushing "in" keeps fiber from dewatering and settling in close fluid chamber clearances and stalling the pump. This design will dilute product considerably and thus must be fully evaluated. The second design function of this arrangement is to vent box pressure to the suction side of the pump. Standard throttle bushing material is glass filled PTFE.

HD Maximum Overhung Load Calculation

Ductile Iron Model	Max. Overhung Load – “F” (lbs.)	Maximum Horsepower with 12” diameter sheave			
		Pump RPM			
		100	200	300	400
70A & 120A	450	4.3	8.6	12.9	17.2
330	600	5.7	11.4	17.1	22.8
600	900	8.6	17.2	25.8	34.4

Use following formula for other speed and sheave diameters:

$$HP = \frac{("F" - \text{lbs.})(\text{Sheave dia.}-\text{inches})(\text{RPM})}{126,048}$$

Note: Stainless Steel will be 67% of above.

HD Maximum Allowable Transmitted Torque on Pump Shafts (Inch-Pounds)

Pump Shaft	Carbon Steel 1141 (Std. On D.I.)	ARMCO 17-4-1025	316 S.S. (Std. On S.S.)	Hast “C”
70A & 120A	12,534	19,497	6,267	10,213
330	21,658	33,691	10,829	17,647
600	29,710	46,215	14,855	24,208

*Transmitted torque is the torque associated with the brake horsepower of a given application, at design speed.

To calculate torque values in inch pounds:

1. Determine BHP for the actual application from published performance curves, at design speed (RPM).
2. Torque (in-lbs.) = $\frac{(\text{BHP})(63,000)}{\text{RPM}}$

Note: Applications using 31 SSU performance curves at pressures at or above 200 PSI must be approved by the factory.

HD Nozzle Loading Data

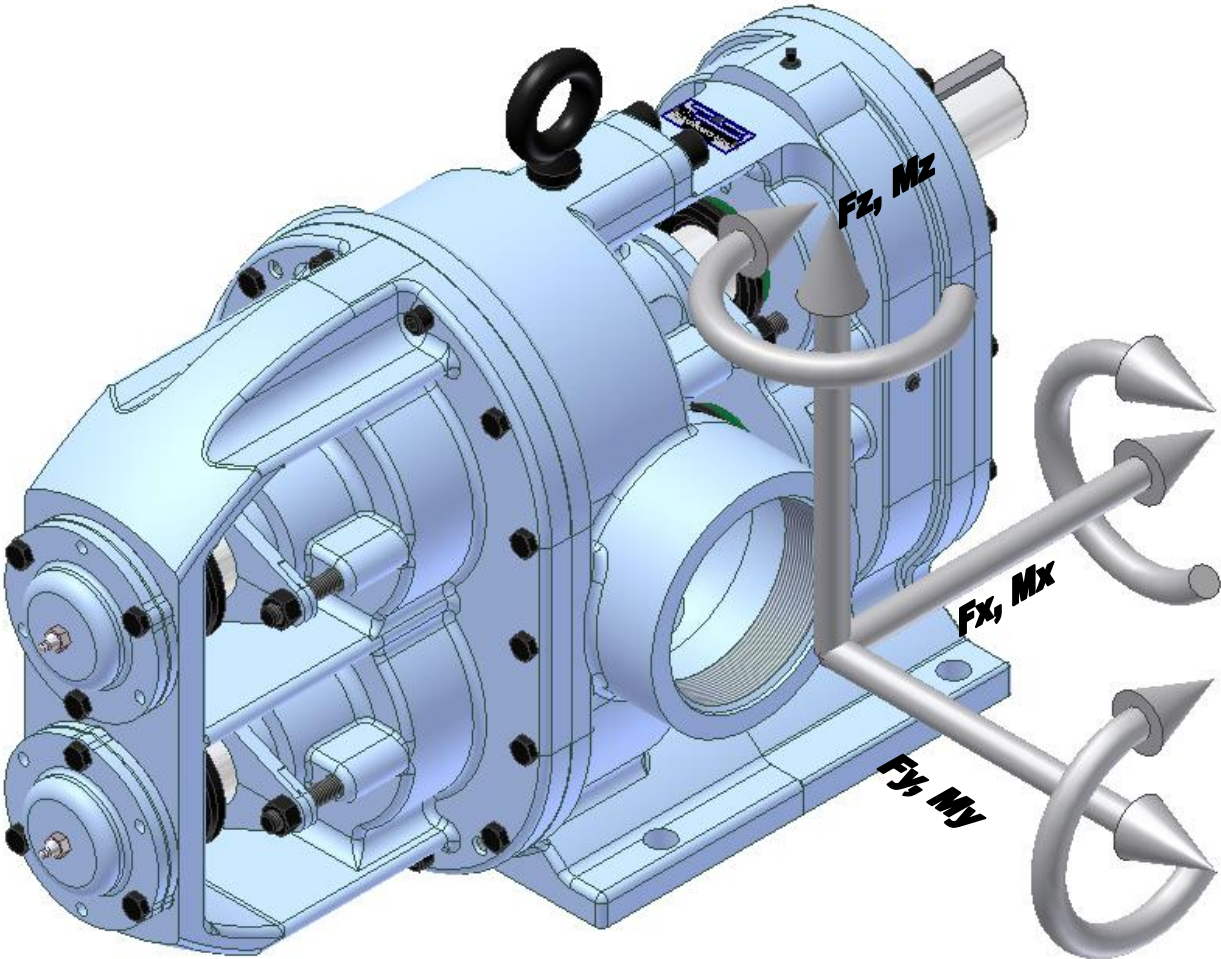

Pump Model	Port Size (In.)	Max. Force = Lbs.	Max. Moment = Lb.In.
120A	3	200	2750
120A & 330	4	250	3150
330	5	300	3600
600	6	500	4100

The official Hydraulic Institute Standard states, "Both suction and discharge piping should be independently supported near the pump so that when the flange bolts are tightened no strain will be transmitted to the pump casing."

HD Model Steam Jacket

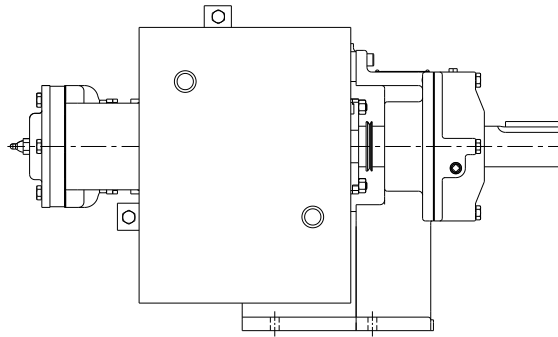

Construction:

The jacket has a fabricated carbon steel plate type insert with an aluminum cast outer shell. Jacket is made in two-piece construction for field installation and/or pump maintenance access. Each half has ½” NPT (internal) in and out ports.

Rating:

Steam or heat transfer fluids:
 150-PSI maximum pressure
 500°F maximum temperature

Application:

Factory or field installed. Standard grade Thermon or other heat transfer cement is applied between pump and jacket for best efficiency. Applications where pumped fluid must be maintained at temperature in order to remain in liquid form so the pump can pump the fluid are ideal for a steam jacket.

General Ph Chart

Increasing Alkalinity ↑↑↑↑	14.0 Ph 13.0 Ph 12.0 Ph 11.0 Ph 10.0 Ph	Ductile Iron
	9.0 Ph 8.0 Ph	Ductile Iron
Neutral Point	7.0 Ph	
Increasing Acidity ↓↓↓↓	6.0 Ph	
	5.0 Ph 4.0 Ph 3.0 Ph 2.0 Ph 1.0 Ph 0.0 Ph	Stainless Steel

HD Maximum Case, Differential, Discharge, and Suction Pressures

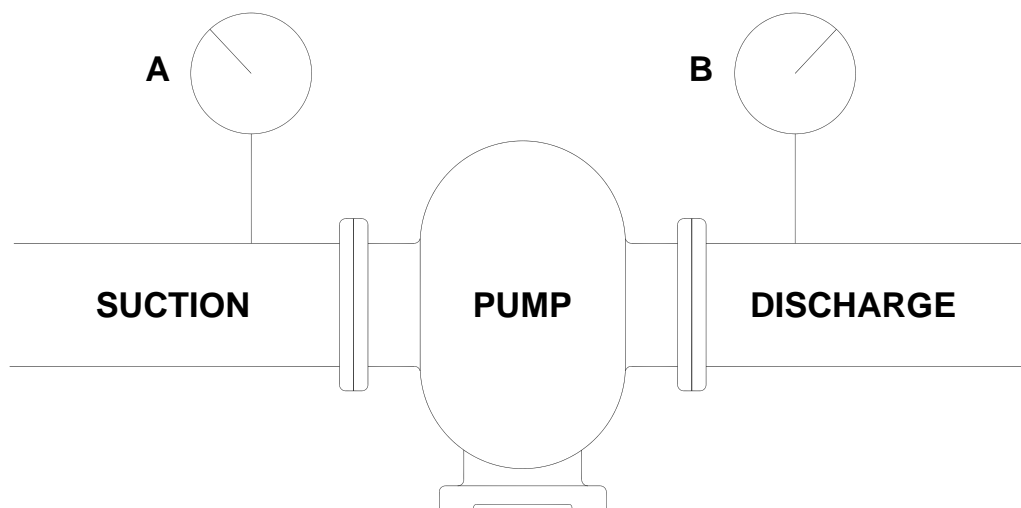

Pump Model	Pump Material of Construction	Max. Case Pressure	Max. Differential Pressure	Max. Discharge Pressure	Max. Suction Pressure
70A	Ductile Iron	500	450	500	350
	Stainless Steel	500	450	500	350
120A	Ductile Iron	500	450	500	350
	Stainless Steel	500	450	500	350
330	Ductile Iron	500	450	500	350
	Stainless Steel	500	450	500	350
600	Ductile Iron	500	450	500	350
	Stainless Steel	500	450	500	350

* Max. Case Pressure for Standard Duty models with wing nuts is 150 PSI for Stainless Steel and 200 PSI for Ductile Iron. 500 PSI rating can be achieved by replacing wing nuts with standard hex head nuts torqued to industry standards.

Flange Ratings (Cast Iron)

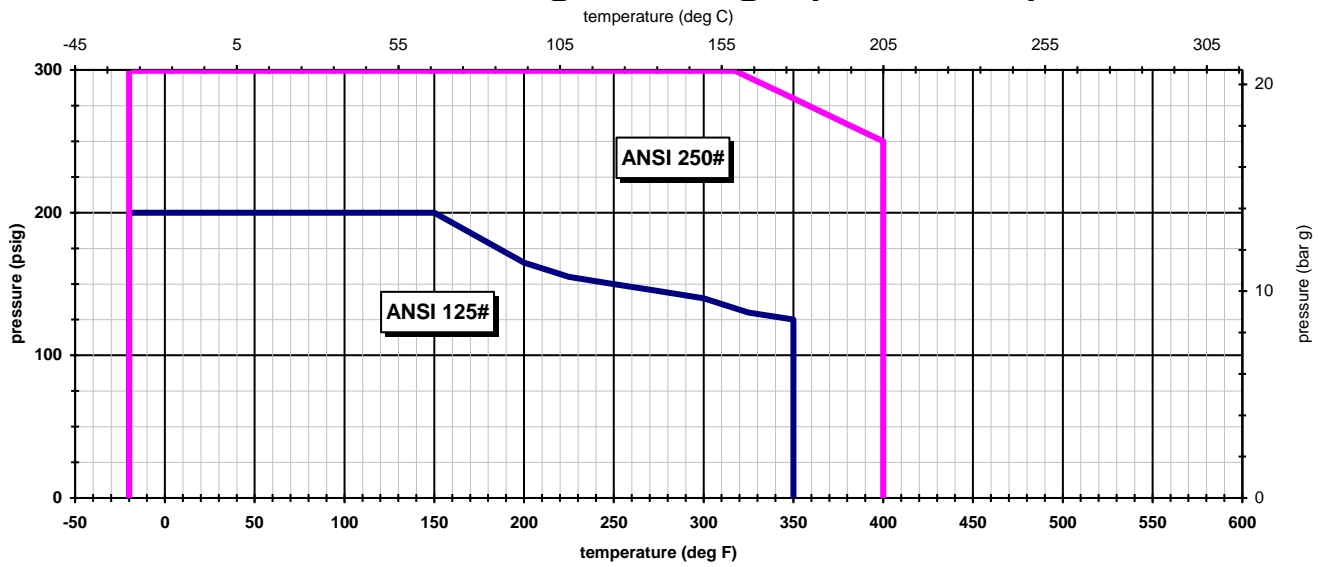

NOTES:

- 1) This chart shows the ratings for flanges only - the maximum pump operating conditions must also be checked.
- 2) Consult the appropriate Tuthill catalog for maximum allowable operating pressures and temperatures, based on pump application conditions and pump features.
- 3) These ratings are based on non-shock pressures.
- 4) ANSI data is from ASME/ANSI B16.1 - 1989 (class A). Consult this spec for more information.

	Warning	Rapid temperature change can result in flange failure and leakage, which can cause property damage or serious injury. Do not exceed cast iron tensile strength when bolting flanges.
--	----------------	--

Flange Ratings (Stainless Steel)

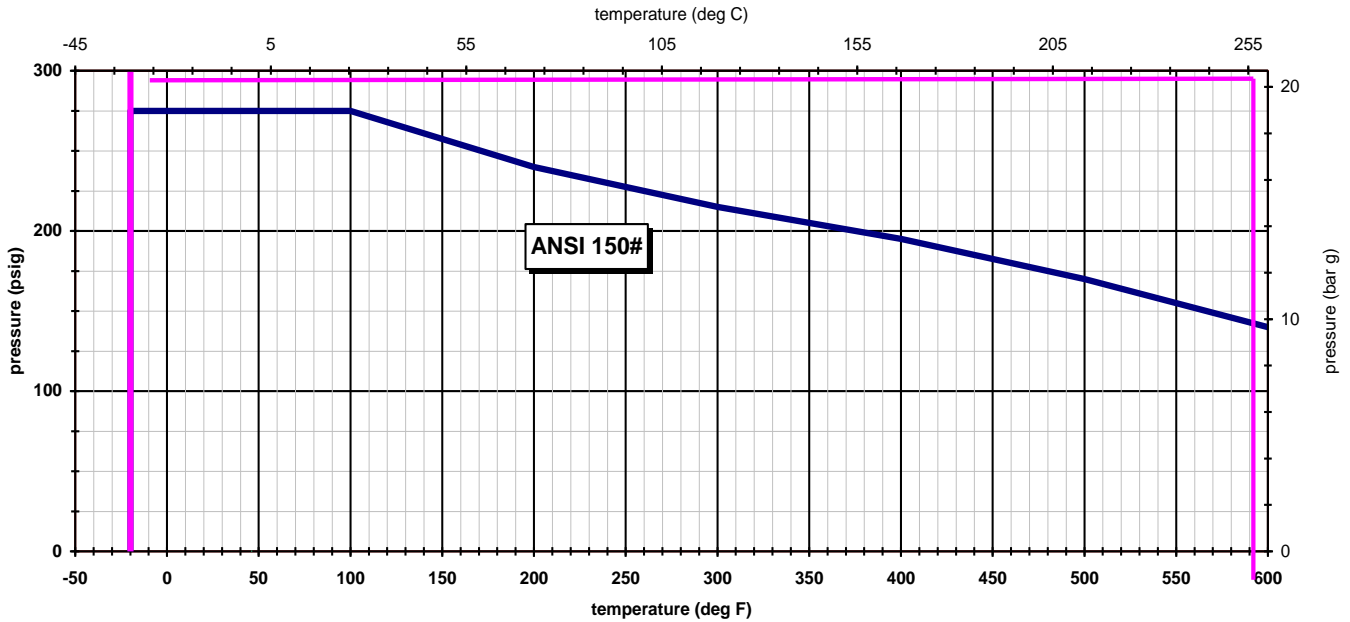

NOTES:

- 1) This chart shows the ratings for flanges only - the maximum pump operating conditions must also be checked.
- 2) Consult the appropriate Tuthill catalog for maximum allowable operating pressures and temperatures, based on pump application conditions and pump features.
- 3) These ratings are based on non-shock pressures.
- 4) ANSI data is from ASME/ANSI B16.5 - 1988 (matl group 2.2). Consult this spec for more information.



Warning

Rapid temperature change can result in flange failure and leakage, which can cause property damage or serious injury. Do not exceed cast iron tensile strength when bolting flanges.