

Magnet drive gear pump-motor units FG100 series



Find out more

The Fluid-o-Tech FG100 series, born from the long experience in mag drive external gear pumps, provides a smart and compact unit which finds easily its location in most machines.

The pump housing is in stainless steel and the non-metallic parts have been selected to comply with the most strict sanitary requirements. The electromagnetic drive delivers a smooth transmission of the rotation, little or no noise and a leak free unit, while the integrated electronic allows for the 24V brushless DC heart of the FG100 to be controlled directly from the logic of the machine. Complete flexibility, dispense after dispense.

The FG100 series combines the external gear pump technology taken to its perfection and a brushless DC motor in a rotor less configuration.

This ensures a top performance with an exceptionally long service life.



MAIN APPLICATIONS

- Espresso coffee machines
- Food processing equipment
- Laser apparatus
- Lubrication
- Medical equipment
- Cooling systems
- Laboratory instrumentation
- Water treatment



TECHNICAL INFORMATION

Pump housing material	AISI 316L	Motor type	24 V BLDC
Gears and bushing material	Peek	Speed range	from 500 to 5000 rpm
Ports	1/8" GAS	Max output power	50 W
Max static pressure	20 bar/290 psi	Motor IP protection	IP 52
Max vacuum	724 mmHg/28.5 inHg	Insulation class	F
Wet lift with water*	~ 8 m/26.2 ft	Unit weight	675 g/1.5 lb

* Priming ability varies with operating conditions and fluid characteristics

OPERATING RANGE

Max ambient temperature	40 °C/104 F	70 °C/150 F	40 °C/104 F
Fluid temperature	95 °C/203 F	55 °C/131 F	40 °C/104 F
Max torque	30 mNm/4.2 in-oz at 5000 rpm	70 mNm/9.9 in-oz at 3500 rpm	100 mNm/714.1 in-oz at 3500 rpm
Min ambient temperature	5 °C/41 F		

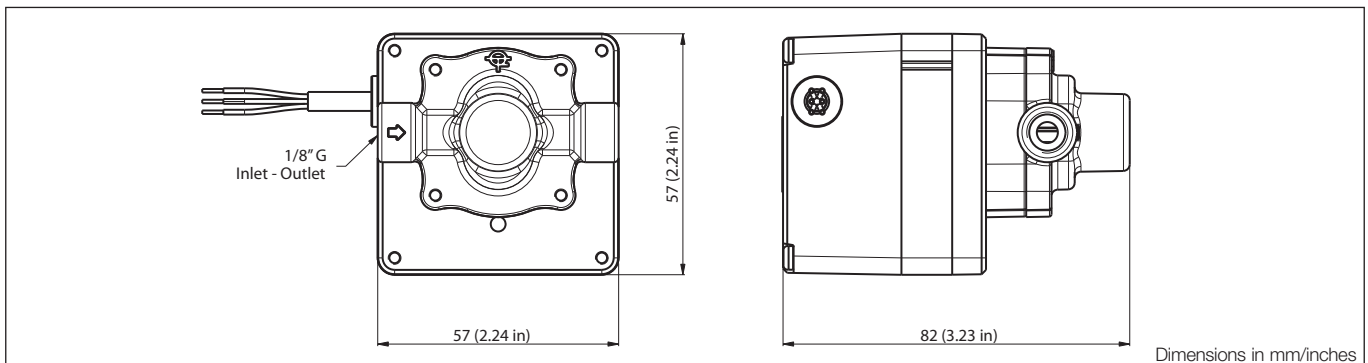

Dimensions in mm/inches

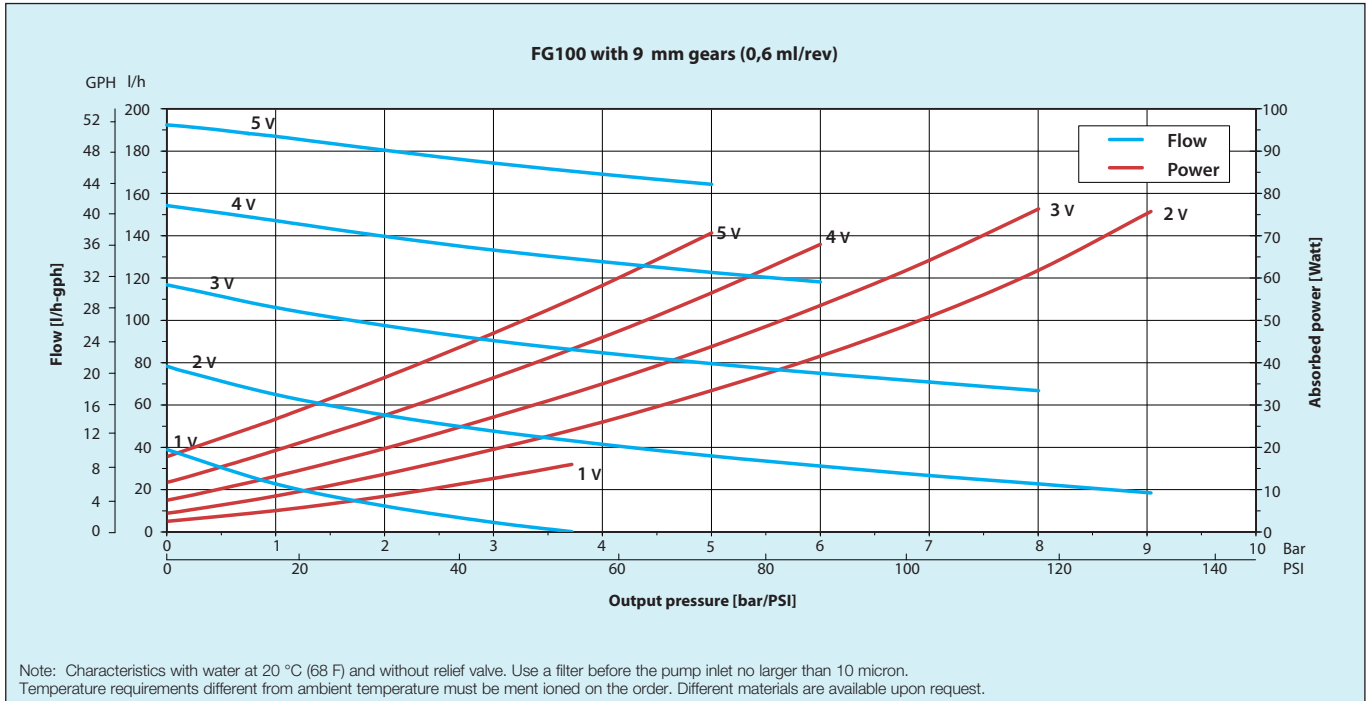

Fluid-o-Tech reserves the right to alter the specifications indicated in this catalogue at any time and without prior notice.

Fluid-o-Tech srl
Via Leonardo da Vinci, 40
20094 Corsico, Milano, Italy
Tel. +39 02 999501
Fax +39 02 99950999
info@fluidotech.it

Fluid-o-Tech Int'l Inc.
161 Atwater St.,
06479 Plantsville CT (USA)
Tel. +1 (860) 276-9270
Fax +1 (860) 620-0193
info@fluid-o-tech.com

Fluid-o-Tech Int'l Inc. Japan
203, 2-17-19, Ebara, Shinagawa
Tokyo 142-0063, Japan
Tel. +81 (0) (3) 3783-9660
Fax +81 (0) (3) 3783-9661
k.kato@fluidotech.com

Fluid-o-Tech Asia (Beijing) Co., Ltd
Jingwei Industrial Zone,
Beifang Huairou, Beijing, 101400, PRC
Tel. +86 (0) (10) 61684650
Fax +86 (0) (10) 61684651
info@fluidotech-asia.com