

FR3210 Series Hi-Flow DC Pump S & E Data Sheet

Technical Information

Motor	
Power -AC 115, 230, 115/230	N/A
HZ 50, 60, 50/60	N/A
Power - DC 12, 24, 12/24	12 VOLT
HP (horsepower) rating	1/2 HP
Power cord length	20'
Power cord gauge	10 AWG
Power cord DC battery connectors	N/A
Amps (FLA)	45 A
RPM	3600
Duty cycle	30 min.
Thermal protection switch	Yes
Circuit protection fuse	Yes (Circuit Breaker)
Certification	UL/cUL Motor
Pump	
Type- rotary, diaphragm, gear, vane	Rotary Vane
GPM in supplied configuration	22.5
GPM open flow - no hose or nozzle	25
By-pass pressure rating (psi) - Max	22 psi
Dry vac (in Hg)	12
Head- Max (ft)	50.8
Anti-siphon valve	None
Inlet - Size / Thread	1-1/4" NPT
Outlet – Size / Thread	1" NPT
Mount	Bung (NPT)
Materials of construction -pump housing	Cast Iron
Materials of construction- wetted material	BUNA
Rotor materials of construction	Powdered Iron
Rotor vane material of construction	Acetal
Compatible fluids	Diesel, gasoline, Bio Diesel
Strainer Mesh Size	20 x 20
Warranty (yr)	2 Years

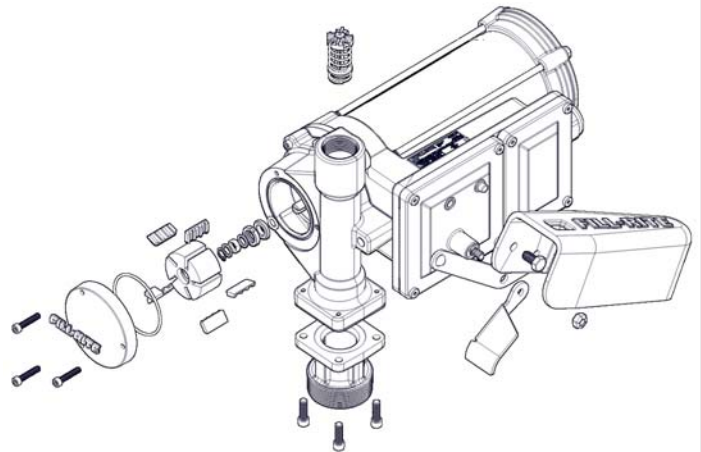
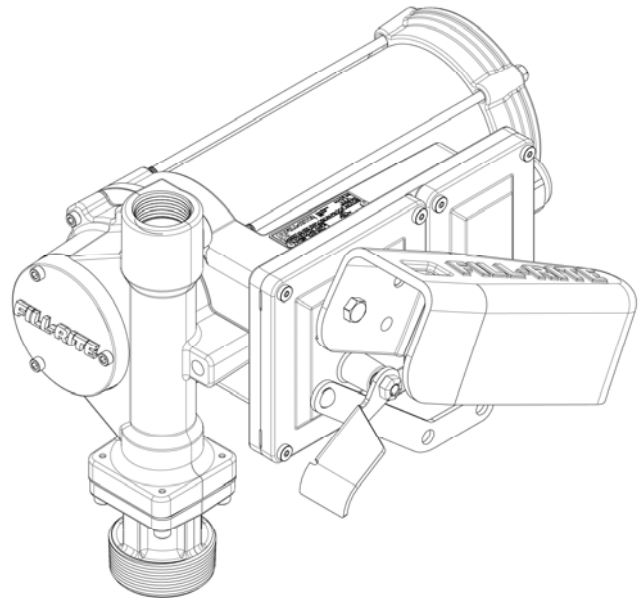

Performance Chart

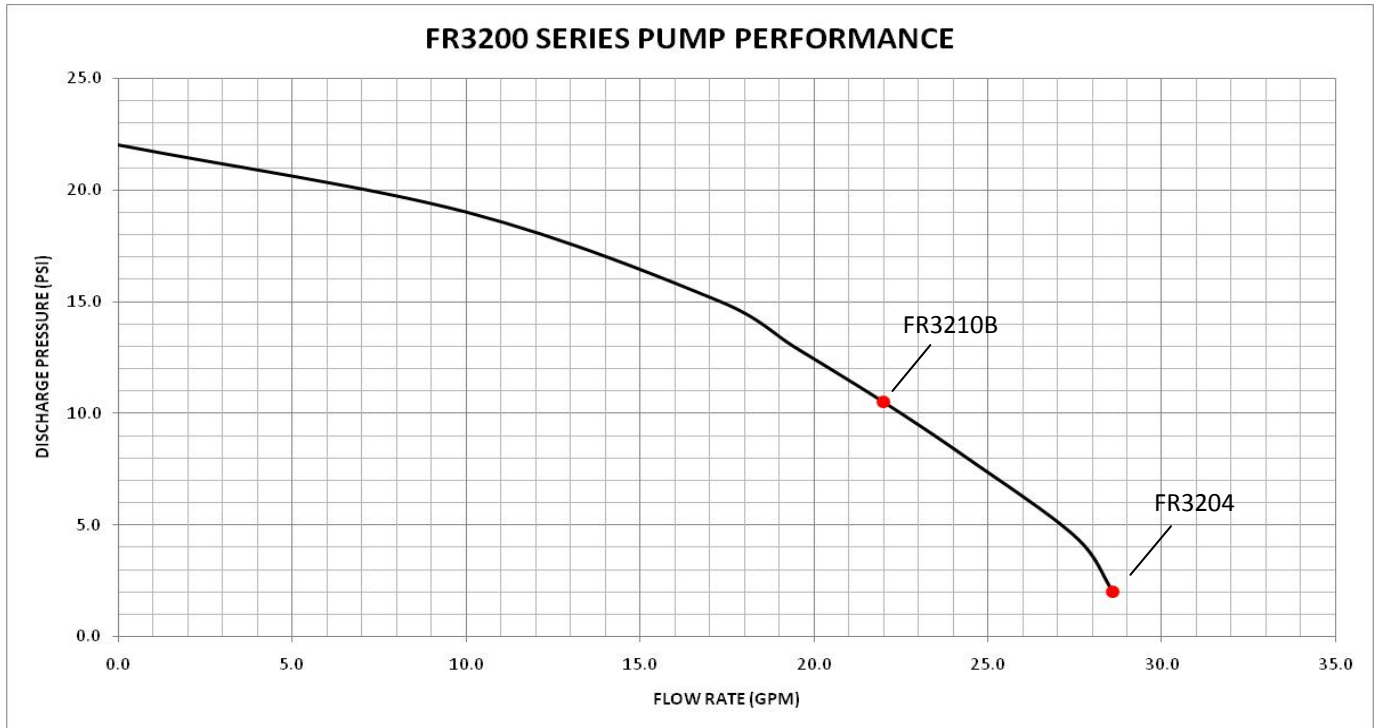

Repair Kits

Kit Number	Description	Parts
KIT320RK	Overhaul Kit	Rotor, rotor cover, vanes, O-ring seal, shaft seal kit, bypass valve, inlet seal & screen, rotor key, attaching hardware
KIT320RG	Rotor & Vane Kit	Rotor cover, rotor, vanes, rotor key, O-ring seal, attaching hardware
KIT320SL	Seal Kit	O-ring, shaft seals, retainer clip
KIT320BV	By-Pass Service Kit	Inlet gasket, screen, bypass valve, valve spring, valve retainer
KIT120NB	Nozzle Boot Kit	Nozzle boot, attaching hardware
KIT320SK	External Seal Kit	O-ring seal, inlet gasket, electrical cover seals
KIT320BG	Inlet Flange Kit	Inlet flange (bung), attaching hardware, inlet seal, screen
KIT320SW	Switch / Breaker Kit	Breaker / switch assembly, switch mounting bracket, attaching hardware, cover gasket
KIT320MK	Motor Kit	Complete motor assembly

Accessories

Accessory	Description
N100DAU13	1" Ultra High Flow Manual Nozzle
FRHMN100S	1" Manual Nozzle
900D	900D Digital Meter
NEW	900D Digital Meter with Pulsar (Coming Soon)
FRH10020	20' x 1" Static Discharge Hose
FRH10012	12' x 1" Static Discharge Hose
NEW	1" multi plane swivel (Coming Soon)