

# Marlow Series 2AM32-P PETROLEUM PUMP

**INSTALLATION, OPERATION AND MAINTENANCE INSTRUCTIONS**



## TABLE OF CONTENTS

<b>SUBJECT</b>	<b>PAGE</b>
Operating and Safety Instrutions.....	3
Maintenance Instructions.....	3
Recommended Precautions .....	3
Operating Instructions .....	4
Operating .....	4
General.....	4
Proper Location .....	4
Connections.....	4
Strainer Advisable.....	4
Starting .....	4
Lubrication .....	4
High Discharge.....	4
Maintenance .....	4
Troubleshooting Guide.....	5
Repair Parts .....	6
Limited Warranty.....	8

Please fill in data from your pump nameplate.  
Warranty information is on page 8.

Pump Model: \_\_\_\_\_

Serial Number: \_\_\_\_\_

Dealer: \_\_\_\_\_

Dealer's Phone Number: \_\_\_\_\_

Date of Purchase: \_\_\_\_\_

Installation Date: \_\_\_\_\_

## Congratulations

You are now the owner of a Goulds pump. This pump was carefully inspected and subjected to final tests before releasing for shipment. In order to assure maximum performance please follow the simple instructions in this manual.

**⚠ WARNING** PUMPING OF VOLATILE PETROLEUM PRODUCTS CAN BE HAZARDOUS. FOR THIS REASON, EXTREME CARE MUST BE EXERCISED AND ALL OPERATING AND SAFETY INSTRUCTIONS STRICTLY ADHERED TO. FAILURE TO DO THIS CAN RESULT IN A FIRE OR EXPLOSION.

**APPLICATION:** This pump is designed to pump petroleum products such as diesel fuel, jet fuel or gasoline in well-ventilated areas that do not contain potentially explosive fumes.

This equipment should be operated only by personnel who have been thoroughly instructed as to the hazards involved and who are familiar with the following operating and safety instructions.

### OPERATING AND SAFETY INSTRUCTIONS

1. Use non-sparking tools when making pump connections.
2. Always securely connect the ground wire to a good ground on the tank being filled, before operating the pump.
3. Do not operate the engine while filling the pump tank with its initial priming liquid.
4. Do not refill engine if running or hot.
5. Do not pump liquids other than water or petroleum products.
6. Do not operate with leaky seal or piping, closed suction or discharge valve or with a fill plug removed.
7. Operate pump only with guard in place.

### MAINTENANCE INSTRUCTIONS

1. If engine is hard to start, or runs rough, move unit to a safe area and check out on water.
2. This engine must be maintained in original condition throughout its use. Prior to each use, inspect the air cleaner, spark arresting muffler, shielded spark plug, shielded spark plug wire, and the enclosed run-stop switch, to make certain that these are not worn or damaged in any way.
3. Use only original replacement parts - this is critical since each part was selected for its safety and high quality.

### RECOMMENDED PRECAUTIONS

1. **APPLICATION:** This pump is designed to pump petroleum products such as diesel fuel, jet fuel or gasoline in well-ventilated areas that do not contain potentially explosive fumes. Primarily intended for fuel transfer or refueling construction equipment at remote open air sites where the lack of electricity makes it impossible to use pumps driven by explosion-proof electric motors.

Pumping of volatile petroleum products can be hazardous. For this reason, extreme care must be exercised and all operating and safety instructions strictly adhered to.

2. As with all self-priming centrifugal pumps, the pump tank must be initially filled with the liquid being pumped. **DO NOT** run the engine while filling the

pump tank. Failure to follow this precaution could result in a fire or explosion.

3. This pump is designed primarily for water and petroleum products use. Before pumping other liquids, carefully read the special note below.
4. Do not subject the pump to a pressure in excess of 75 psi.
5. Should the fluid temperature rise more than 50°F. ambient, expansion joints must be installed on both the suction and discharge ports to relieve any stress on the pump casing.
6. No modifications, additions or deletions should be made to the pump.
7. Prime movers powering the pumps may operate at high temperatures. Keep hands off mufflers and manifolds to avoid burns.
8. In systems where shock wave pressures may be generated, protective devices (check valve/gate valve, etc.) must be installed on discharge line to prevent shock wave pressures from entering casing. A discharge check valve is required when operating against high static heads.
9. Do not refill engine fuel tank while power unit is running or while hot. Prevent splashing of gasoline or other fuel while filling supply tank.
10. Do not use in a combustible atmosphere.
11. Make daily checks of the tightness of suction and discharge pipe, drain, filler plug and pump gaskets. Check tightness of gasoline tank filler cap each time tank is filled. Operation should not proceed until all of the above items have been checked and are tight.

**⚠ CAUTION** The performance of Goulds Water Technology is based upon clear, cold, fresh water with suction conditions as shown on the performance curve. If used to pump other liquids, pump performance may differ from rated performance based on the different specific gravity, temperature, viscosity, etc. of the liquid being pumped. However, a standard pump may not be safe for pumping all types of liquids, such as toxic, volatile or chemical liquids, or liquids under extreme temperatures or pressures. Please consult your Goulds Water Technology catalog as well as local codes and general references to determine the appropriate pumps for your particular application. Since it is impossible for us to anticipate every application of a Goulds pump, if you plan to use the pump for other than a water or petroleum product application, consult Goulds Water Technology beforehand to determine whether such application may be proper or safe under the circumstances. Failure to do so could result in property damage or personal harm.

**⚠ WARNING** **THE INSTALLATION OF THE PUMP SHALL INCLUDE ADEQUATE DRAINAGE OR LOCATED SUCH THAT OTHER EQUIPMENT OR PROPERTY WOULD NOT BE DAMAGED IN THE EVENT OF ANY LEAKAGE. THE PUMP SHOULD NOT BE INSTALLED ABOVE EQUIPMENT OR PROPERTY UNLESS ADEQUATE DRAINAGE IS PROVIDED. FAILURE TO COMPLY WITH THIS WARNING COULD RESULT IN PROPERTY DAMAGE.**

**⚠ WARNING** **OVERTIGHTENING OF THE CASING FASTENERS COULD DAMAGE THE FASTENER, RESULTING IN LEAKAGE AND PROPERTY DAMAGE.**

## OPERATING INSTRUCTIONS

### GENERAL

- Our shipping container has been specifically designed to prevent transit damage. However, any indications of damage or shortage should be carefully noted on the delivery ticket and a claim filed promptly with the carrier.

### PROPER LOCATION

- By placing your Goulds pump on a firm, level foundation, you reduce the chance of its falling into the liquid and damaging the engine. You also insure proper oil lubrication of the engine and obtain optimum engine performance. Best pump operation is obtained by locating the pump so as to minimize the suction lift as much as practical, keeping in mind that a pump can push liquid more effectively than it can pull or draw liquid.

### CONNECTIONS

- Connections at the easily accessible suction and discharge ports can be made with either oil-resistant hose or pipe. The use of strongly reinforced suction hose will prevent collapsing of the hose during operation. New hose washers should be used at the couplings to prevent trouble-causing leaks. Pipe joint compound that will not dissolve in the liquid being pumped should be used on all pipe joints. All hose or pipe should be independently supported to eliminate excessive strain on the pump. For best results your hose should discharge higher than the pump to prevent siphoning action when the unit is shut down.
- We strongly recommend the use of extra-heavy close faced nipples on the suction and discharge ports of the 2AM32-P petroleum pump. Also, be sure to apply pipe compound on the nipples before installing. When pumping petroleum products, it is particularly important to use suitable hose, gaskets and fittings to minimize the chance of a leak occurring.
- Also, be certain that the splash guard special air cleaner and spark arresting muffler are used on every application.

### STRAINER ADVISABLE

- Protect your investment, use a strainer. Strainers are attached to the suction line to prevent stones and foreign debris from damaging the impeller or diffuser, resulting in reduced performance. Stones lodged inside the pump can cause premature wear and poor performance. To keep the strainer from working into the sediment, suspend the hose from the end of a rope. If you do not have a strainer, your Goulds Water Technology dealer can supply one in the correct size.

### STARTING

- Follow the engine manufacturer's instructions carefully. Fill the pump tank with liquid before starting.
- Your pump has been designed to prime itself in a few minutes with the engine running fast. High suction lifts require additional time and reduce the performance of the pump. Should you have difficulty, refer to the Troubleshooting Guide section.
- Goulds Water Technology prime and reprime themselves providing the tank is filled with liquid. Should you lose this liquid from the tank accidentally or by draining purposely, it will be necessary to refill it with liquid before starting. **DO NOT** operate the engine while filling the pump tank with its initial priming liquid.

## LUBRICATION

- The latest engineering advancements have been incorporated into our self-lubrication shaft seal. The liquid being pumped cools and lubricates the seal. Running the pump dry will damage the seal. Always keep liquid in the tank, and no further lubrication of the pump end is necessary. Refer to engine manual for proper engine lubrication.
- It is particularly important when pumping petroleum products to regularly check the condition of the seal. At the first sign of a leak in the seal, the unit should be shut down immediately and the seal replaced with a new one of the same design.

### HIGH DISCHARGE

- If you have a vertical discharge line rising 30 feet or more, your pump is subject to severe back pressures when it is shut down. This back pressure can cause damage to the pump. To prevent the possibility of this damage, install a check valve on the discharge line as near to the pump as possible, and the shock will be stopped at the valve.

### MAINTENANCE

1. The pump is fitted with a mechanical shaft seal which requires no other lubrication than the liquid in which it operates.
2. On occasion, the mechanical shaft seal may become worn and must be replaced. Follow the replacement instructions enclosed with each seal assembly. Do not operate with a leaky seal.
3. When pump is not in use for several days, or for winter storage, drain all the liquid from the tank.
4. Follow the engine manufacturer's manual for periodic maintenance and adjustment. Also follow their procedure for winterizing the engine as set forth in the manual.
5. Storage of engine requires rotation of engine shaft to the compression stroke, thus inhibiting rust on the engine valves.
6. Maintenance and functional problems relating to the engine should be referred directly to the manufacturer's service station.
7. This engine is modified by:
  - a. An Air Maze air cleaner, with oil-wetted metallic element. A small amount of engine oil should be added per instruction label on the outside of the air cleaner.
  - b. A spark arresting muffler, centrifugal type. It must be mounted with the clean-out plug at the bottom. Carbon particles should be removed through the clean-out hole on a regular basis. Do this only when engine is cold and in a well-ventilated area free from petroleum vapors.
  - c. A shielded spark plug and shielded spark plug wire.
  - d. An enclosed run-stop switch on the side of the engine shroud.

## TROUBLESHOOTING GUIDE

The following are some common causes of problems that may arise.

<b>SYMPTOMS</b>	<b>PROBABLE CAUSE</b>	<b>RECOMMENDED ACTION</b>
<b>Will Not Prime</b>	No liquid Air leak in suction line Blocked suction line Worn seal	Fill tank with liquid. Tighten all joints or remake using new compound. Clean strainer or suction line. Install new seal.
<b>Stops Pumping Until Engine is Stopped and Restarted</b>	Collapsing suction hose lining	Replace hose.
<b>Suddenly Stops Pumping</b>	Clogged strainer or hose	Clean hose and strainer.
<b>Slowly Stops Pumping</b>	Clogged impeller, diffuser or lines	Clean out debris and use strainer.
<b>Leakage Around Pump Shaft While Operating</b>	Worn seal	Replace seal.
<b>Performance Poor</b>	Worn impeller or seal Engine not up to speed Suction lift too high Suction hose too small	Replace with new impeller or seal. Refer to engine manual. Relocate pump closer to supply. Use larger size hose.

## REPAIR PARTS LIST

Key	Description	Part Number
1	Pipe plug	16K142
2	Casing	16K143
3	Gasket, o-ring	16K144
4	Impeller, open	16K145
5	Seal assembly	16K146
6	Bracket	16K147
7	Slinger	16K148
8	Splash deflector	16K149
9	Muffler guard	16K150
10	Handle	16K151
11	Ground cable	16K152
12	Base	16K153
13	Locknut	16K154
14	Air cleaner	16K155
15	Spark arresting muffler	16K156

Key	Description	Part Number
16	Shielded spark plug wire assembly with Magneto	16K157
16a	Shield, spark plug wire	16K158
16b	Magneto B&S Engine - N/A	16K159
17	Spark plug	16K160
18	Rotary ignition switch	16K161
19	Engine assembly (includes engine plus items 14 through 18)	16K162
20	Gasket, o-ring	16K163
21	Capscrew	16K164
22	Lockwasher	
23	Nut	
24	Capscrew	
25	Capscrew	
26	Capscrew	
27	Capscrew	
28	Lockwasher	
29	Nut	

### IMPORTANT:

How to use the drawing to order parts:

The table above indicates the repair part number for parts indicated in the drawing. Refer to the drawing - locate the part that matches your pump part. Contact your local Goulds Water Technology dealer and supply him with the number of the part required or place your order directly in eCOM. For units manufactured prior to May 2018, contact customer service with your model number and serial number, which are located on the pump nameplate to determine appropriate repair parts.

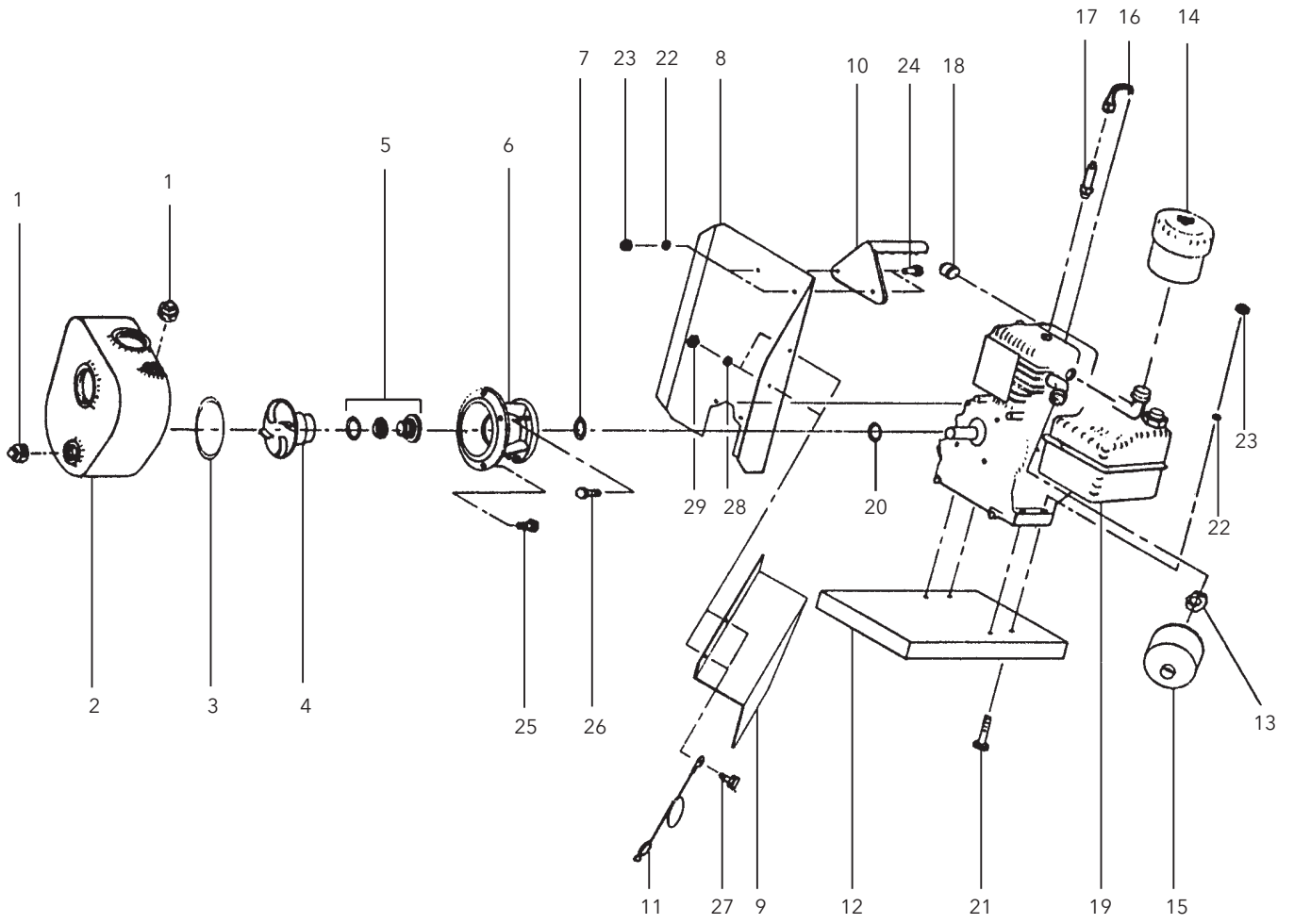

## LIMITED CONSUMER WARRANTY

For goods sold for personal, family or household purposes, Seller warrants the goods purchased hereunder (with the exception of membranes, seals, gaskets, elastomer materials, coatings and other "wear parts" or consumables all of which are not warranted except as otherwise provided in the quotation or sales form) will be free from defects in material and workmanship for a period of one (1) year from the date of installation or eighteen (18) months from the product date code, whichever shall occur first, unless a longer period is provided by law or is specified in the product documentation (the "Warranty").

Except as otherwise required by law, Seller shall, at its option and at no cost to Buyer, either repair or replace any product which fails to conform with the Warranty provided Buyer gives written notice to Seller of any defects in material or workmanship within ten (10) days of the date when any defects or non-conformance are first manifest. Under either repair or replacement option, Seller shall not be obligated to remove or pay for the removal of the defective product or install or pay for the installation of the replaced or repaired product and Buyer shall be responsible for all other costs, including, but not limited to, service costs, shipping fees and expenses. Seller shall have sole discretion as to the method or means of repair or replacement. Buyer's failure to comply with Seller's repair or replacement directions shall terminate Seller's obligations under this Warranty and render this Warranty void. Any parts repaired or replaced under the Warranty are warranted only for the balance of the warranty period on the parts that were repaired or replaced. The Warranty is conditioned on Buyer giving written notice to Seller of any defects in material or workmanship of warranted goods within ten (10) days of the date when any defects are first manifest.

Seller shall have no warranty obligations to Buyer with respect to any product or parts of a product that have been: (a) repaired by third parties other than Seller or without Seller's written approval; (b) subject to misuse, misapplication, neglect, alteration, accident, or physical damage; (c) used in a manner contrary to Seller's instructions for installation, operation and maintenance; (d) damaged from ordinary wear and tear, corrosion, or chemical attack; (e) damaged due to abnormal conditions, vibration, failure to properly prime, or operation without flow; (f) damaged due to a defective power supply or improper electrical protection; or (g) damaged resulting from the use of accessory equipment not sold or approved by Seller. In any case of products not manufactured by Seller, there is no warranty from Seller; however, Seller will extend to Buyer any warranty received from Seller's supplier of such products.

**Goulds Water Technology Policy Concerning Online Sales to Consumers.** Homeowners using the Internet to locate information regarding residential water systems, residential wastewater systems, controls and tanks may discover several sites offering a direct-to-consumer purchasing opportunity. Residential water and wastewater systems are mission critical applications and are designed to be installed by qualified professionals. Goulds Water Technology has an extensive nationwide network of distributors and dealers, including authorized resellers. For a complete view of Goulds Water Technology recognized distributors, dealers and authorized resellers, please refer to our locator at: <http://goulds.com/sales-service/>

No warranty is offered on Goulds Water Technology equipment purchased over the Internet, including web-based options from unauthorized retailers. This policy is necessary to ensure that Goulds Water Technology equipment is installed properly, in compliance with applicable laws, rules and codes, in a manner that addresses safety concerns and the proper performance of Goulds Water Technology equipment.

THE FOREGOING WARRANTY IS PROVIDED IN PLACE OF ALL OTHER EXPRESS WARRANTIES. ALL IMPLIED WARRANTIES, INCLUDING BUT NOT LIMITED TO THE IMPLIED WARRANTIES OF MERCHANTABILITY AND FITNESS FOR A PARTICULAR PURPOSE, ARE LIMITED TO ONE (1) YEAR FROM THE DATE OF INSTALLATION OR EIGHTEEN (18) MONTHS FROM THE PRODUCT DATE CODE, WHICHEVER SHALL OCCUR FIRST. EXCEPT AS OTHERWISE REQUIRED BY LAW, BUYER'S EXCLUSIVE REMEDY AND SELLER'S AGGREGATE LIABILITY FOR BREACH OF ANY OF THE FOREGOING WARRANTIES ARE LIMITED TO REPAIRING OR REPLACING THE PRODUCT AND SHALL IN ALL CASES BE LIMITED TO THE AMOUNT PAID BY THE BUYER FOR THE DEFECTIVE PRODUCT. IN NO EVENT SHALL SELLER BE LIABLE FOR ANY OTHER FORM OF DAMAGES, WHETHER DIRECT, INDIRECT, LIQUIDATED, INCIDENTAL, CONSEQUENTIAL, PUNITIVE, EXEMPLARY OR SPECIAL DAMAGES, INCLUDING BUT NOT LIMITED TO LOSS OF PROFIT, LOSS OF ANTICIPATED SAVINGS OR REVENUE, LOSS OF INCOME, LOSS OF BUSINESS, LOSS OF PRODUCTION, LOSS OF OPPORTUNITY OR LOSS OF REPUTATION.

Some states do not allow limitations on how long an implied warranty lasts, so the above limitation may not apply to you. Some states do not allow the exclusion or limitation of incidental or consequential damages, so the above exclusions may not apply to you. This warranty gives you specific legal rights, and you may also have other rights which may vary from state to state.

To make a warranty claim, check first with the dealer from whom you purchased the product or visit [www.xylem.com](http://www.xylem.com) for the name and location of the nearest dealer providing warranty service.



**Xylem Inc.**  
2881 East Bayard Street Ext., Suite A,  
Seneca Falls, NY 13148  
Phone: (800) 453-6777 Fax: (888) 322-5877  
[www.xylem.com/goulds](http://www.xylem.com/goulds)

Xylem is a trademark of Xylem Inc.  
Goulds is a registered trademark of Goulds Pumps, Inc. and is used under license.  
© 2022 Xylem Inc. IM080 Revision Number 6 May 2022