



TECHNICAL MANUAL

TTECHS R6

Wastewater Technical Manual

FOR GOULDS WATER TECHNOLOGY, BELL & GOSSETT, RED JACKET SERIES AND CENTRIPRO

INDEX

Friction Loss

Plastic 3
Steel..... 4
Fittings..... 5

Pipe Volume and Velocity

Storage of Water in Various Size Pipes..... 5
Minimum Flow to Maintain 2 Ft./Sec..... 5

Sewage Pump

Sizing and Selection 6

Electrical Data

Agency Listing / Removing Plug Letters 10
Transformer Sizes..... 10
Three Phase Unbalance 11
NEMA Panel Enclosures 12

Determining Flow Rates

Full Pipe Flow 13
Pipe Not Running Full..... 13
Discharge Rate in Gallons per Minute..... 13

Terms and Usable Formulas

Definitions..... 14
Basic Formulas 14

Typical Installations

Sump 16
Effluent and Sewage..... 17

Variable Speed Drives

Wastewater Pumps 18

Panel Layouts and Wiring Diagrams

Duplex Single Phase..... 20
Duplex Three Phase..... 22
Simplex Three Phase 24
Simplex Single Phase 25
Switch Diagrams 27
Sewage Control Panels and Switches 28

FRICITION LOSS

PLASTIC PIPE: FRICTION LOSS (IN FEET OF HEAD) PER 100 FT.

GPM	GPH	¾"	½"	¾"	1"	1¼"	1½"	2"	2½"	3"	4"	6"	8"	10"
		ft.	ft.	ft.	ft.	ft.	ft.	ft.	ft.	ft.	ft.	ft.	ft.	ft.
1	60	4.25	1.38	.356	.11									
2	120	15.13	4.83	1.21	.38	.10								
3	180	31.97	9.96	2.51	.77	.21	.10							
4	240	54.97	17.07	4.21	1.30	.35	.16							
5	300	84.41	25.76	6.33	1.92	.51	.24							
6	360		36.34	8.83	2.69	.71	.33	.10						
8	480		63.71	15.18	4.58	1.19	.55	.17						
10	600		97.52	25.98	6.88	1.78	.83	.25	.11					
15	900			49.68	14.63	3.75	1.74	.52	.22					
20	1,200			86.94	25.07	6.39	2.94	.86	.36	.13				
25	1,500				38.41	9.71	4.44	1.29	.54	.19				
30	1,800					13.62	6.26	1.81	.75	.26				
35	2,100					18.17	8.37	2.42	1.00	.35	.09			
40	2,400					23.55	10.70	3.11	1.28	.44	.12			
45	2,700					29.44	13.46	3.84	1.54	.55	.15			
50	3,000						16.45	4.67	1.93	.66	.17			
60	3,600						23.48	6.60	2.71	.93	.25			
70	4,200							8.83	3.66	1.24	.33			
80	4,800							11.43	4.67	1.58	.41			
90	5,400							14.26	5.82	1.98	.52			
100	6,000								7.11	2.42	.63	.08		
125	7,500								10.83	3.80	.95	.13		
150	9,000									5.15	1.33	.18		
175	10,500									6.90	1.78	.23		
200	12,000									8.90	2.27	.30		
250	15,000										3.36	.45	.12	
300	18,000										4.85	.63	.17	
350	21,000										6.53	.84	.22	
400	24,000											1.08	.28	
500	30,000											1.66	.42	.14
550	33,000											1.98	.50	.16
600	36,000											2.35	.59	.19
700	42,000												.79	.26
800	48,000												1.02	.33
900	54,000												1.27	.41
950	57,000													.46
1000	60,000													.50

FRICITION LOSS

STEEL PIPE: FRICTION LOSS (IN FEET OF HEAD) PER 100 FT.

GPM	GPH	3/8"	1/2"	3/4"	1"	1 1/4"	1 1/2"	2"	2 1/2"	3"	4"	5"	6"	8"	10"
		ft.	ft.	ft.	ft.	ft.	ft.	ft.	ft.	ft.	ft.	ft.	ft.	ft.	ft.
1	60	4.30	1.86	.26											
2	120	15.00	4.78	1.21	.38										
3	180	31.80	10.00	2.50	.77	.10									
4	240	54.90	17.10	4.21	1.30	.34									
5	300	83.50	25.80	6.32	1.93	.51	.24								
6	360		36.50	8.87	2.68	.70	.33	.10							
7	420		48.70	11.80	3.56	.93	.44	.13							
8	480		62.70	15.00	4.54	1.18	.56	.17							
9	540			18.80	5.65	1.46	.69	.21							
10	600			23.00	6.86	1.77	.83	.25	.11	.04					
12	720			32.60	9.62	2.48	1.16	.34	.15	.05					
15	900			49.70	14.70	3.74	1.75	.52	.22	.08					
20	1,200			86.10	25.10	6.34	2.94	.87	.36	.13					
25	1,500				38.60	9.65	4.48	1.30	.54	.19					
30	1,800				54.60	13.60	6.26	1.82	.75	.26					
35	2,100				73.40	18.20	8.37	2.42	1.00	.35					
40	2,400				95.00	23.50	10.79	3.10	1.28	.44					
45	2,700					30.70	13.45	3.85	1.60	.55					
70	4,200					68.80	31.30	8.86	3.63	1.22	.35				
100	6,000						62.20	17.40	7.11	2.39	.63				
150	9,000							38.00	15.40	5.14	1.32	.08			
200	12,000							66.30	26.70	8.90	2.27	.736	.30	.08	
250	15,000							90.70	42.80	14.10	3.60	1.20	.49	.13	
300	18,000								58.50	19.20	4.89	1.58	.64	.16	.0542
350	21,000								79.20	26.90	6.72	2.18	.88	.23	.0719
400	24,000								103.00	33.90	8.47	2.72	1.09	.279	.0917
450	27,000								130.00	42.75	10.65	3.47	1.36	.348	.114
500	30,000								160.00	52.50	13.00	4.16	1.66	.424	.138
550	33,000								193.00	63.20	15.70	4.98	1.99	.507	.164
600	36,000								230.00	74.80	18.60	5.88	2.34	.597	.192
650	39,000									87.50	21.70	6.87	2.73	.694	.224
700	42,000									101.00	25.00	7.93	3.13	.797	.256
750	45,000									116.00	28.60	9.05	3.57	.907	.291
800	48,000									131.00	32.40	10.22	4.03	1.02	.328
850	51,000									148.00	36.50	11.50	4.53	1.147	.368
900	54,000									165.00	40.80	12.90	5.05	1.27	.410
950	57,000									184.00	45.30	14.30	5.60	1.41	.455
1000	60,000									204.00	50.20	15.80	6.17	1.56	.500

FRICITION LOSS

EQUIVALENT NUMBER OF FEET STRAIGHT PIPE FOR DIFFERENT FITTINGS

Size of fittings, Inches	1/2"	3/4"	1"	1 1/4"	1 1/2"	2"	2 1/2"	3"	4"	5"	6"	8"	10"
90° Ell	1.5	2.0	2.7	3.5	4.3	5.5	6.5	8.0	10.0	14.0	15	20	25
45° Ell	0.8	1.0	1.3	1.7	2.0	2.5	3.0	3.8	5.0	6.3	7.1	9.4	12
Long Sweep Ell	1.0	1.4	1.7	2.3	2.7	3.5	4.2	5.2	7.0	9.0	11.0	14.0	
Close Return Bend	3.6	5.0	6.0	8.3	10.0	13.0	15.0	18.0	24.0	31.0	37.0	39.0	
Tee-Straight Run	1	2	2	3	3	4	5						
Tee-Side Inlet or Outlet or Pitless Adapter	3.3	4.5	5.7	7.6	9.0	12.0	14.0	17.0	22.0	27.0	31.0	40.0	
Ball or Globe Valve Open	17.0	22.0	27.0	36.0	43.0	55.0	67.0	82.0	110.0	140.0	160.0	220.0	
Angle Valve Open	8.4	12.0	15.0	18.0	22.0	28.0	33.0	42.0	58.0	70.0	83.0	110.0	
Gate Valve-Fully Open	0.4	0.5	0.6	0.8	1.0	1.2	1.4	1.7	2.3	2.9	3.5	4.5	
Check Valve (Swing)	4	5	7	9	11	13	16	20	26	33	39	52	65
In Line Check Valve (Spring) or Foot Valve	4	6	8	12	14	19	23	32	43	58			

Example:

(A) 100 ft. of 2" plastic pipe with one (1) 90° elbow and one (1) swing check valve.

90° elbow - equivalent to 5.5 ft. of straight pipe
 Swing check - equivalent to 13.0 ft. of straight pipe
 100 ft. of pipe - equivalent to 100 ft. of straight pipe
 118.5 ft. = Total equivalent pipe

Figure friction loss for 118.5 ft. of pipe.

(B) Assume flow to be 80 GPM through 2" plastic pipe.

1. Friction loss table shows 11.43 ft. loss per 100 ft. of pipe.
2. In step (A) above we have determined total ft. of pipe to be 118.5 ft.
3. Convert 118.5 ft. to percentage $118.5 \div 100 = 1.185$
4. Multiply 11.43 $\times 1.185$
 13.54455 or 13.5 ft. = Total friction loss in this system.

PIPE VOLUME AND VELOCITY

STORAGE OF WATER IN VARIOUS SIZE PIPES

Pipe Size	Volume in Gallons per Foot	Pipe Size	Volume in Gallons per Foot
1/4	.06	6	1.4
1/2	.09	8	2.6
2	.16	10	4.07
3	.36	12	5.87
4	.652		

MINIMUM FLOW TO MAINTAIN 2FT./SEC. *SCOURING VELOCITY IN VARIOUS PIPES

Pipe Size	Minimum GPM	Pipe Size	Minimum GPM
1/4	9	6	180
1/2	13	8	325
2	21	10	500
3	46	12	700
4	80		

* Failure to maintain or exceed this velocity will result in clogged pipes. Based on schedule 40 nominal pipe.

SEWAGE PUMP SELECTION

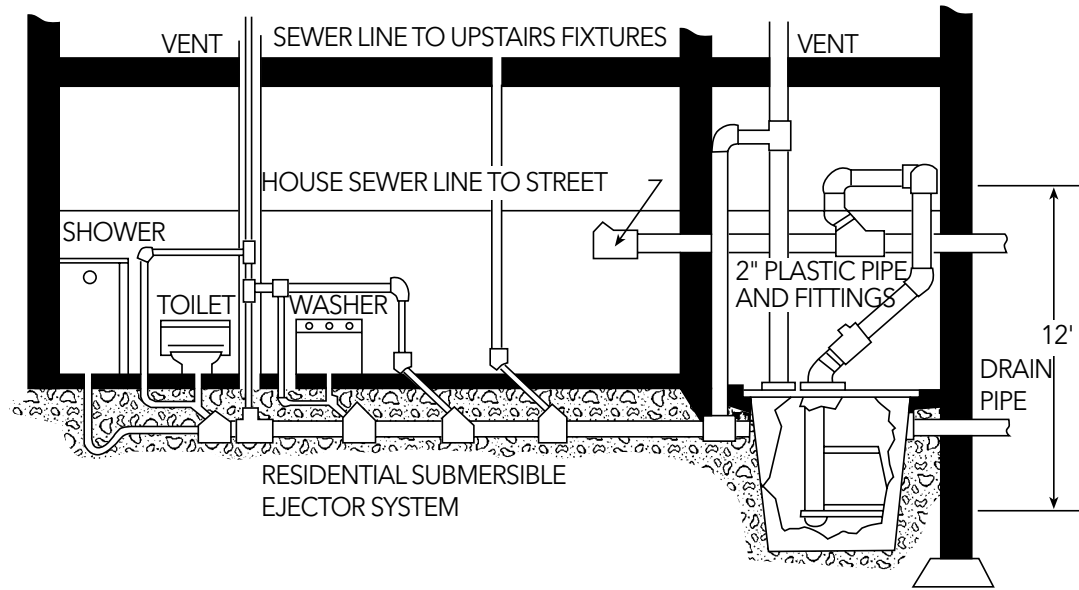

The primary function for which the Submersible Sewage Pump is designed is the handling of sewage and other fluids containing unscreened nonabrasive solids and wastes. In order to insure a maximum of efficiency and dependable performance, careful selection of pump size is necessary. Required pump capacity will depend upon the number and type of fixtures discharging into the sump basin, plus the type of facility served. The fundamentals involved in selecting a pump for a Water System can be applied to selecting a Submersible Sewage Pump. By answering the three (3) questions concerning capacity, suction, and discharge conditions we will know what is required of the pump and be able to select the right pump from the catalog.

1. To simplify the selection of the proper size Submersible Sewage Pump, the general rule is to base the pump capacity on the number of toilets the pump will be serving. This differs from the selection of the proper pump for a Water System in that question 1, "Water Needed" is reversed. How much liquid do we want to dispose of rather than how much do we need? The following chart will help determine pump capacity:

**Sewage Selection Table
for Residential or Commercial Systems**

Number of Bathrooms	GPM
1	20
2	30

The above selection table takes into consideration other fixtures which will drain only water into the sewage basin.

Therefore, pump capacity should not be increased for lavatories, bathtubs, showers, dishwashers, or washing machines. When no toilets are involved in the facility served, for example, a laundromat, the major fixture discharging waste should be considered. In this case, the chart should read "Maximum Number of Washing Machines."

In areas where drain tile from surrounding lawns or fields enters the sump, groundwater seepage can be determined as follows:

- 14 GPM for 1,000 sq. ft. of **sandy soil**
- 8 GPM for 1,000 sq. ft. of **clay soil**

If the calculated groundwater seepage is less than one-fourth of the pump capacity required based on the number of toilets, the pump capacity should not be increased. Any seepage over the allowed one-fourth should be added to the required pump capacity.

2. Since the pump is submerged in the liquid to be pumped, there is no suction lift. Question 2 does NOT become a factor in pump selection.

3. Answering Question 3, discharge conditions is the final step in selecting a Submersible Sewage Pump. Only the vertical distance between the pump and the highest point in the discharge piping, plus friction losses in discharge pipe and fittings affect discharge pressure. (Friction losses can be obtained from the friction table in this Selection Manual.)

Normally service pressure is not a consideration. The total of the vertical distance, plus the friction losses is the required discharge head in feet.

WASTEWATER PUMPS SIZING AND SELECTION

WHAT DO YOU NEED TO KNOW TO SELECT A SEWAGE PUMP?

- 1. Size solids to be handled.**
 - Effluent (liquid only) - <1"
 - Residential - 1½" or larger
 - Commercial/Industrial - 2½" or larger
- 2. Capacity required.**
 - 1 bath - 20 GPM
 - 2-3 baths - 30 GPM
 - 4-5 baths - 45 GPM
- 3. Pump/Motor Run Time**
Units up to 1½ HP should run a minimum of 1 minute. Two (2) HP and larger units should run a minimum of 2 minutes.

- 4. Formula for Total Dynamic Head:**
Vertical elevation
+ friction loss (pipe + fittings)
+ Pressure Requirements (x 2.31')

Total head in feet

Note: Wastewater pumps are designed to pump effluent with some suspended solids, not solids with some effluent.

- 5.** Must maintain **minimum** velocity of 2 ft./second (see index).
- 6.** Must turn storage in the discharge pipe a **minimum** of one time per cycle. (See index).

- 7. Are receiver basin and cover required?**
 - 8. What is the power available?**
 - Phase - 1Ø or 3Ø
 - Voltage - 115, 200, 230, 460 or 575 V
 - Hertz - 50 or 60 Hz
 - 9. What pipe size will be used?**
 - 10. Simplex or Duplex System?**
(Duplex when service cannot be interrupted)
- Note: State and local codes take preference.**

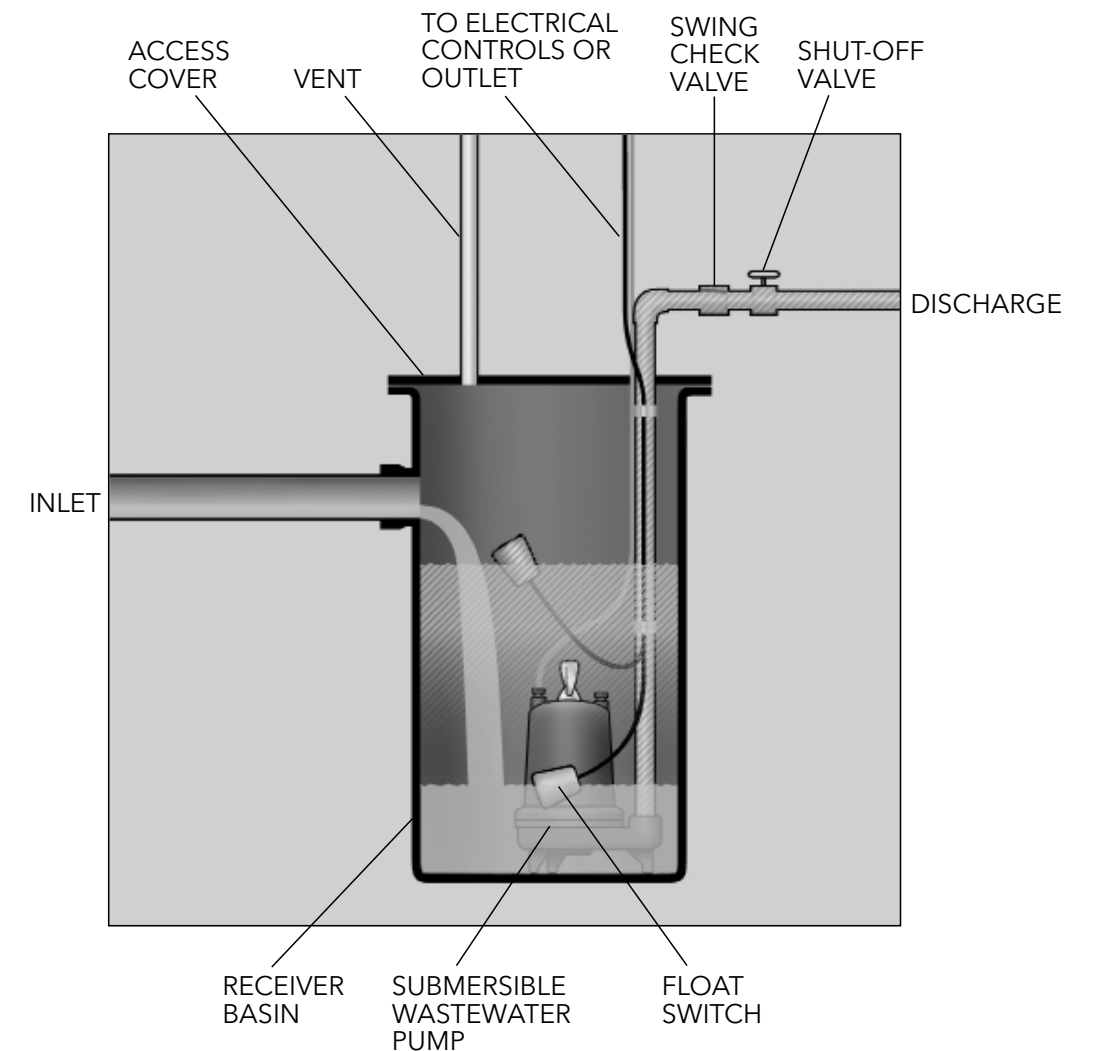
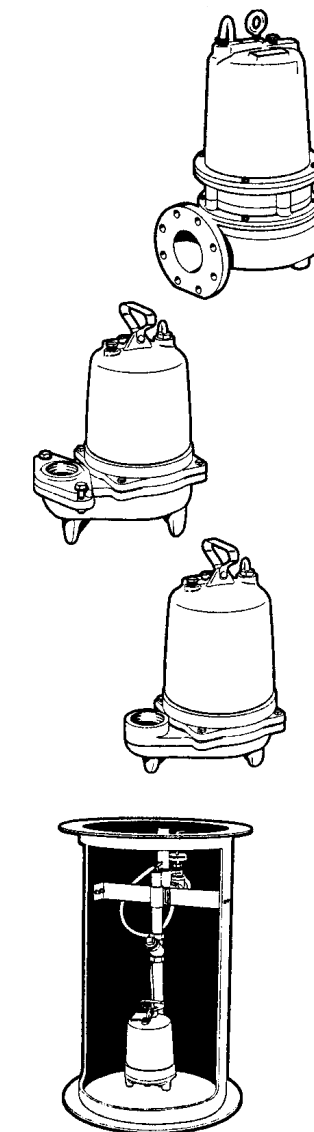

FLOW RATE CALCULATION

Residential Sizing

BATHROOM COUNT

Number of Bathrooms	Flow Rate per Minute
1	20
2	30
3	40
4	50
5	60
6	70

FIXTURE COUNT V = Value style fixture T = Tank Style Fixture

Fixture	Type	Count
Toilet	V	6
Toilet	T	3
Lav Sink	V or T	1
Tub	V or T	2
Shower	V or T	2
Full Body Shower	Add Flow rate: 9 to 65 Gallons per minute to total	
Kitchen Sink	V or T	2
Dishwasher	V or T	4
Wash Machine	V or T	8
Bidet	V or T	3
Icemaker	V or T	3
Hose Bib	V or T	4

Fixture	Quantity	Count	Total Count
Toilets	3	3	9
Tub and Shower	2	4	8
Full body shower			15
Lav Sink		1	3
Kitchen Sink	1	2	2
Dishwasher	1	4	4
Icemaker	1	3	3
Wash Machine	1	8	8
Hose Bib	1	4	4
Total			56

PLUMBING WATER SYSTEMS

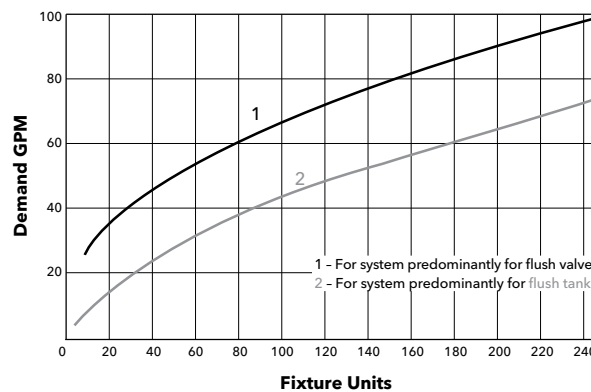

"Hunter" Estimate Curves for Demand Load

Commercial Sizing

OCCUPANT SIZING

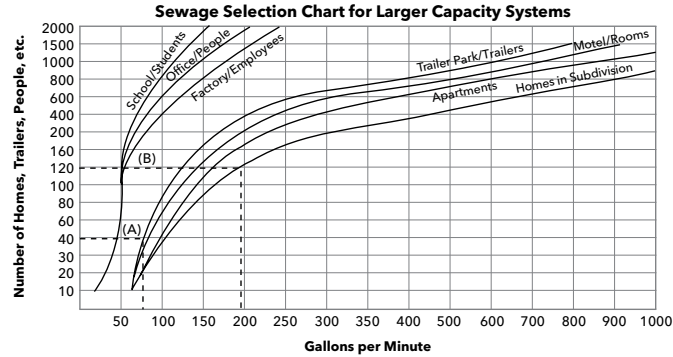

FIXTURE COUNT V = Value style fixture T = Tank Style Fixture

Fixture	Type	Count
Toilet	V	10
Toilet	T	5
Pedestal Urinal	V or T	10
Stall Urinal	V or T	5
Lav Sink	V or T	3
Kitchen Sink	V or T	4
Tub	V or T	4
Shower	V or T	4
Dishwasher	V or T	4
Icemaker	V or T	3
Commercial Wash. Machine	V or T	6
Hose Bib - Commercial	V or T	6
Full Body Shower	Add Flow rate 9 to 65 Gallons per minute to total	

Fixture	Quantity	Count	Total Count
Toilet	50	10	500
Lav Sink	50	3	150
Shower	50	4	200
Full body shower	50	15	750
Dishwasher	50	4	200
Icemaker	50	3	150
Wash Machine	10	6	60
Dishwasher	10	4	40
Hose bib	2	6	12
Total			2062

PLUMBING WATER SYSTEMS

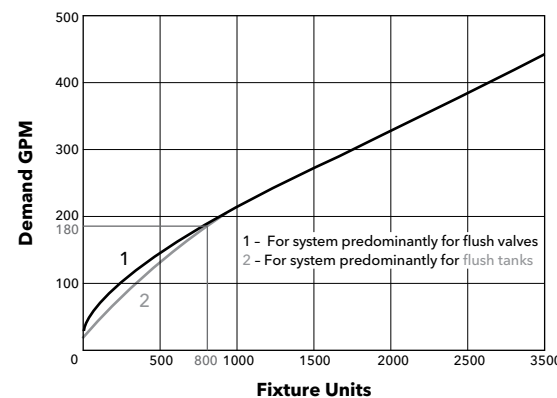

"Hunter" Estimate Curves for Demand Load

FLOW CALCULATION EXAMPLE

To Calculate Flow with Fixture Counts

Take total number of each style fixture X Count for that fixture. Add all fixture total counts. Add Full Body shower flow rate to total.

Use "Hunter" estimate curves for Demand Load for appropriate style fixtures. (Valve style fixtures are predominant in Commercial buildings; Tank style fixtures are predominant in Residential).

COMMERCIAL BUILDING EXAMPLE:

Valve Style Fixtures

- 25 Toilets
- 25 Lav sinks
- 25 Tubs
- 6 Kitchen Sinks
- 2 Commercial Washing Machines
- 1 Dishwasher

Count Calculation

25 Toilets	X 10 Count	= 250
25 Lav Sinks	X 3 Count	= 75
25 Tubs	X 4 Count	= 100
6 Kitchen Sinks	X 4 Count	= 24
2 Commercial	X 6 Count	= 12
1 Dishwasher	X 4 Count	= 4
Total		465 Count

Plumbing Water Systems

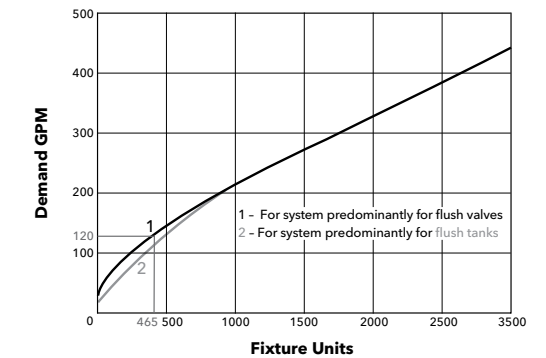

"Hunter" Estimate Curves for Demand Load

HEAD CALCULATION

Example: Fig. 1. A two-bathroom home is situated such that the city sewer main is located above the basement drain facilities. Groundwater seepage through drain tile into the sump is estimated at 6 GPM. The vertical distance from the pump to the highest point in the discharge piping is 12 feet.

A pump capable of pumping 30 GPM is required (seepage is less than one-fourth of the pump capacity so it is automatically included). The discharge head must be 12 feet, plus any friction loss in the approximately 15 feet of pipe, 3-90° elbows, 3-45° elbows, and check valve.

Assume plastic pipe is used.

1. RATE OF FLOW = 30 GPM

Two (2) toilets, includes seepage up to one-fourth of selected pump capacity. 6 GPM is less than the 7.5 GPM allowable so no correction is necessary.

2. SUCTION CONDITIONS - Flooded Suction

3. DISCHARGE CONDITIONS

- Vertical Differential 12.0'
- Friction losses @ 30 GPM
- 15' of 2" pipe (1.8' per 100' of pipe) = .2' F.L.
- 3-2", 90° elbows = 16.5 equivalent feet
- 3-2", 45° elbows = 7.5 equivalent feet
- 1-check valve = 19.0 equivalent feet
- Total = 43.0 equivalent feet = .6' F.L.

Total Discharge Head = 12.8'

Referring to the catalog, we find that a 1/3 HP Sewage Pump should be adequate for the job.

Example: The same conditions as in the previous example exist, except the house is located on a large tract of sandy soil where the groundwater seepage is estimated @ 20 GPM.

1. RATE OF FLOW = 30 GPM

Two (2) toilets, includes seepage up to one-fourth of selected pump capacity - 7.5 GPM.

The additional 12.5 GPM (20-7.5) must be added to the required pump capacity - **12.5 GPM**

2. SUCTION CONDITIONS _____ Flooded Suction

3. DISCHARGE CONDITIONS

- Vertical Differential - 12.0'
- Friction losses @ 42.5 GPM
- 15' of 2" pipe (3.5' per 100' of pipe) = .5' F.L.
- 3-2", 90° elbows = 16.5 equivalent feet
- 3-2", 45° elbows = 7.5 equivalent feet
- 1-check valve = 19.0 equivalent feet
- Total = 43.0 equivalent feet or 1.5' F.L.

Total Discharge Head = 14.0'

Referring again to the catalog, we find that a 1/3 HP Sewage Pump should be adequate for this installation.

BASIN SIZING

CALCULATING BASIN SIZE

1. Choosing Diameter

A minimum of 24" is required for simplex. Duplex stations normally start at 36", but require much larger for larger diameter discharge pumps.

For example: A pump that flows 100 GPM, requires a 2-minute run time. A duplex station with a diameter of 36" holds 4.4 gallons (see Chart A) per inch.

50 GPM x 2 minutes = 100 gallons

100 gallons / 4.4 gallons per inch 22.72" for pump down.

22.72" would be used for (E).

2. Sizing Depth

Inlet and Float Location Basin Sizing Method

1. Top of basin to bottom of the inlet (A) + in.
2. Inlet to "Alarm" float (B) + in.
3. "Alarm" to "Lag" float (C) + in.
4. "Lag" to "On" float (D) + in.
5. Pump down (E) + 17.86 in.
(Note A)
6. Floor of basin to top of pump case + 19.0 in.
(Note B)

Note A = Minimum suggested basin diameter for duplex configuration is 36". Volume by inch of basin divided by 2 x's pumping rate.

Note B = Most pumps are approximately 19" tall. Pump should remain covered during pumping.

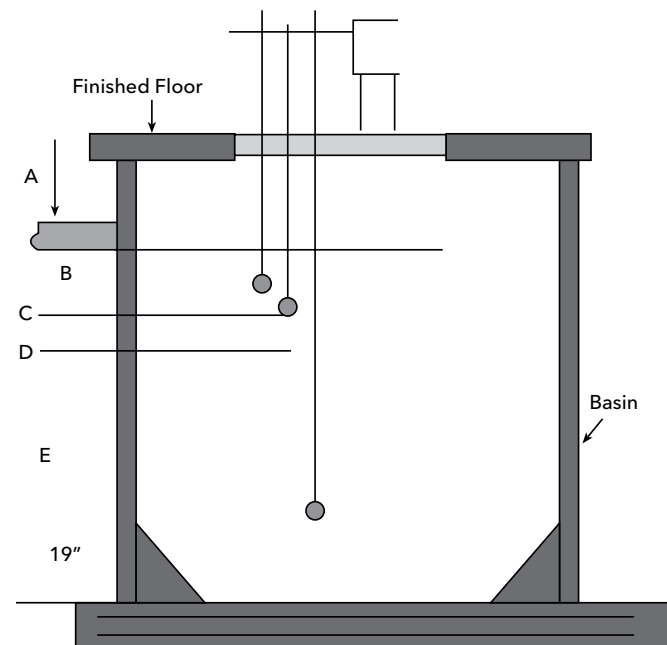

ELECTRICAL DATA

AGENCY LISTINGS AND POWER CORD PLUG REMOVAL

Our single-phase sump, effluent and sewage pumps with 115, 208 and 230 volt motors up to and including 1 HP are now built with NEMA three-prong grounding plug power cords. This allows qualified electricians or professional pump installers to easily connect the pumps; according to U.S. National (NEC), Canadian (CSA), state, provincial and local electrical codes, to a properly rated piggyback float switch for automatic operation.

NOTICE: This statement is written for the intent purpose of verifying to electrical inspectors that according to both UL and CSA standards it is allowable to remove the plug ends for direct wiring to a disconnect switch, control panel or hard wired float switch. Removing the plug end does not violate our UL Listing or CSA/CUS certification in any way. Always follow the aforementioned codes when making connections to the bare leads once the plug is removed. Plug removal information and wiring diagrams may be found in the Installation Manual supplied with the pump and in this booklet. Please use this statement in the event an inspector needs written assurance of this policy.

TRANSFORMER SIZES

A full three phase supply is recommended for all three phase motors, consisting of three individual transformers or one three phase transformer. "Open" delta or wye connections using only two transformers can be used, but are more likely to cause problems from current unbalance.

Transformer ratings should be no smaller than listed in the table for supply power to the motor alone.

TRANSFORMER CAPACITY REQUIRED FOR SUBMERSIBLE MOTORS

Submersible 3Ø Motor HP Rating	Total Effective KVA Required	Smallest KVA Rating - Each Transformer	
		Open WYE DELTA 2 Transformers	WYE or DELTA 3 Transformers
1½	3	2	1
2	4	2	1½
3	5	3	2
5	7½	5	3
7½	10	7½	5
10	15	10	5
15	20	15	7½
20	25	15	10
25	30	20	10
30	40	25	15
40	50	30	20
50	60	35	20
60	75	40	25
75	90	50	30
100	120	65	40

APPLICATION - THREE PHASE UNBALANCE

THREE PHASE POWER UNBALANCE

A full three phase supply is recommended for all three phase motors, consisting of three individual transformers or one three phase transformer. So-called "open" delta or wye connections using only two transformers can be used, but are more likely to cause problems, such as poor performance overload tripping or early motor failure due to current unbalance. Transformer ratings should be no smaller than listed in Table 2 on page 3 for supply power to the motor alone.

Checking and correcting rotation and current unbalance

- Establish correct motor rotation by running in both directions. Change rotation by exchanging any two of the three motor leads. The rotation that gives the most water flow is always the correct rotation.
- After correct rotation has been established, check the current in each of the three motor leads and calculate the current unbalance as explained in 3 below.

If the current unbalance is 2% or less, leave the leads as connected.

If the current unbalance is more than 2%, current readings should be checked on each leg using each of the three possible hook-ups. Roll the motor leads across the starter in the same direction to prevent motor reversal.
- To calculate percent of current unbalance:
 - Add the three line amp values together.
 - Divide the sum by three, yielding average current.
 - Pick the amp value which is furthest from the average current (either high or low).
 - Determine the difference between this amp value (furthest from average) and the average.
 - Divide the difference by the average. Multiply the result by 100 to determine percent of unbalance.

4. Current unbalance should not exceed 5% at service factor load or 10% at rated input load. If the unbalance cannot be corrected by rolling leads, the source of the unbalance must be located and corrected. If, on the three possible hookups, the leg farthest from the average stays on the same power lead, most of the unbalance is coming from the power source. However, if the reading farthest from average moves with the same motor lead, the primary source of unbalance is on the "motor side" of the starter. In this instance, consider a damaged cable, leaking splice, poor connection, or faulty motor winding.

Phase designation of leads for CCW rotation viewing shaft end

To reverse rotation, interchange any two leads.

Phase 1 or "A" - Black Motor Lead or T1

Phase 2 or "B" - White Motor Lead or T2

Phase 3 or "C" - Red Motor Lead or T3

Notice: Phase 1, 2 and 3 may not be L1, L2 and L3.

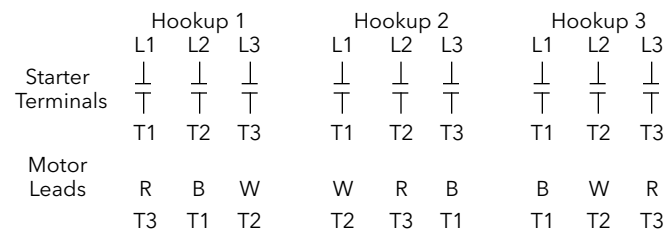

Example:

T3-R = 51 amps	T2-W = 50 amps	T1-B = 50 amps
T1-B = 46 amps	T3-R = 48 amps	T2-W = 49 amps
T2-W = 53 amps	T1-B = 52 amps	T3-R = 51 amps
Total = 150 amps	Total = 150 amps	Total = 150 amps
÷ 3 = 50 amps	÷ 3 = 50 amps	÷ 3 = 50 amps
- 46 = 4 amps	- 48 = 2 amps	- 49 = 1 amp
4 ÷ 50 = .08 or 8%	2 ÷ 50 = .04 or 4%	1 ÷ 50 = .02 or 2%

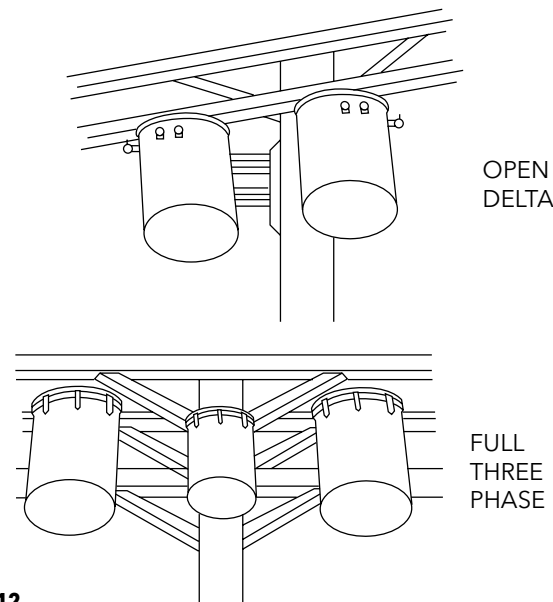

FIGURE 12

ELECTRICAL DATA

NEMA CONTROL PANEL ENCLOSURES

Enclosure Rating	Explanation
NEMA 1 ① General Purpose	To prevent accidental contact with enclosed apparatus. Suitable for application indoors where not exposed to unusual service conditions.
NEMA 2 Driptight	To prevent accidental contact, and in addition, to exclude falling moisture or dirt.
NEMA 3 ① Weatherproof (Weatherproof Resistant)	Protection against specified weather hazards. Suitable for use outdoors.
NEMA 3R ① Raintight	Protects against entrance of water from a beating rain. Suitable for general outdoor application not requiring sleetproof.
NEMA 4 ① Watertight	Designed to exclude water applied in form of hose stream. To protect against stream of water during cleaning operations, etc.
NEMA 4X ① Watertight & Corrosion Resistant	Designed to exclude water applied in form of hose stream. To protect against stream of water during cleaning operations, etc. Corrosion Resistant.
NEMA 5 Dust Tight	Constructed so that dust will not enter enclosed case. Being replaced in some equipment by NEMA 12.
NEMA 6 Submersible	Intended to permit enclosed apparatus to be operated successfully when submerged in water under specified pressure and time.
NEMA 7 Hazardous Locations Class I - Air Break	Designed to meet application requirements of National Electrical Code for Class 1, Hazardous Locations (explosive atmospheres). Circuit interruption occurs in air.
NEMA 8 Hazardous Locations A, B, C or D Class II - Oil Immersed	Identical to NEMA 7 above, except the apparatus is immersed in oil.
NEMA 9 Hazardous Locations E, F or G Class II	Designed to meet application requirements of National Electrical Code for Class II Hazardous Locations (combustible dusts, etc.).
NEMA 10 Bureau of Mines Permissible	Meets requirements of U.S. Bureau of Mines. Suitable for use in coal mines.
NEMA 11 Dripproof Corrosion Resistant	Provides oil immersion of apparatus such that it is suitable for application where equipment is subject to acid or other corrosive fumes.
NEMA 12 Driptight, Dusttight	For use in those industries where it is desired to exclude dust, lint, fibers and flyings, or oil or Industrial coolant seepage.

① Types available from Xylem, Residential and Commercial Water.

DETERMINING FLOW RATES

FULL PIPE FLOW - CALCULATION OF DISCHARGE RATE USING HORIZONTAL OPEN DISCHARGE FORMULA

An L-shaped measuring square can be used to estimate flow capacity, using the chart below. As shown in illustration, place 4" side of square so that it hangs down and touches the water. The horizontal distance shown "A" is located in the first column of the chart and you read across to the pipe diameter (ID) to find the gallons per minute discharge rate.

Example: A is 8" from a 4" ID pipe = a discharge rate of 166 GPM.

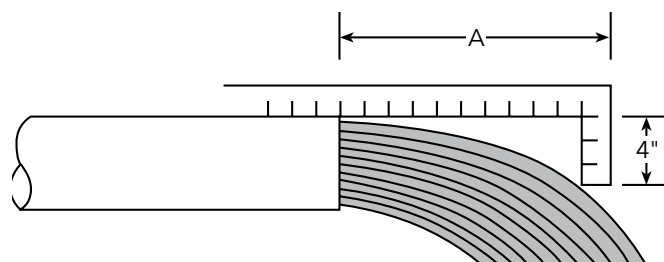

PIPE NOT RUNNING FULL - CALCULATION OF DISCHARGE RATE USING AREA FACTOR METHOD

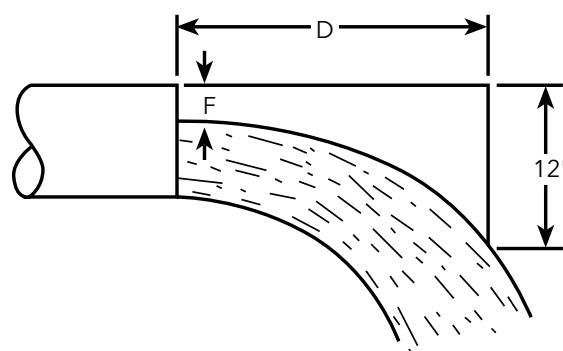

Flow (GPM) = A x D x 1.093 x F
 A = Area of pipe in square inches
 D = Horizontal distance in inches
 F = Effective area factor from chart
 Area of pipe equals inside Dia.² x 0.7854

Example: Pipe inside diameter = 10 in.
 D = 20 in.
 F = 2½ in.
 A = 10 x 10 x 0.7854 = 78.54 square in.
 $R\% = \frac{F}{D} = \frac{2.5}{10} = 25\%$
 F = 0.805
 Flow = 78.54 x 20 x 1.039 x 0.805 = 1314 GPM

Ratio F/D = R %	Eff. Area Factor F	Ratio F/D = R %	Eff. Area Factor F
5	0.981	55	0.436
10	0.948	60	0.373
15	0.905	65	0.312
20	0.858	70	0.253
25	0.805	75	0.195
30	0.747	80	0.142
35	0.688	85	0.095
40	0.627	90	0.052
45	0.564	95	0.019
50	0.500	100	0.000

Flow From Horizontal Pipe (Not Full)

DISCHARGE RATE IN GALLONS PER MINUTE/NOMINAL PIPE SIZE (ID)

Horizontal Dist. (A) Inches	Pipe Diameter												
	1"	1¼"	1½"	2"	2½"	3"	4"	5"	6"	8"	10"	12"	
4	5.7	9.8	13.3	22.0	31.3	48.5	83.5						
5	7.1	12.2	16.6	27.5	39.0	61.0	104	163					
6	8.5	14.7	20.0	33.0	47.0	73.0	125	195	285				
7	10.0	17.1	23.2	38.5	55.0	85.0	146	228	334	380			
8	11.3	19.6	26.5	44.0	62.5	97.5	166	260	380	665	1060		
9	12.8	22.0	29.8	49.5	70.0	110	187	293	430	750	1190	1660	
10	14.2	24.5	33.2	55.5	78.2	122	208	326	476	830	1330	1850	
11	15.6	27.0	36.5	60.5	86.0	134	229	360	525	915	1460	2100	
12	17.0	29.0	40.0	66.0	94.0	146	250	390	570	1000	1600	2220	
13	18.5	31.5	43.0	71.5	102	158	270	425	620	1080	1730	2400	
14	20.0	34.0	46.5	77.0	109	170	292	456	670	1160	1860	2590	
15	21.3	36.3	50.0	82.5	117	183	312	490	710	1250	2000	2780	
16	22.7	39.0	53.0	88.0	125	196	334	520	760	1330	2120	2960	
17		41.5	56.5	93.0	133	207	355	550	810	1410	2260	3140	
18			60.0	99.0	144	220	375	590	860	1500	2390	3330	
19				110	148	232	395	620	910	1580	2520	3500	
20					156	244	415	650	950	1660	2660	3700	
21						256	435	685	1000	1750	2800		
22							460	720	1050	1830	2920		
23								750	1100	1910	3060		
24									1140	2000	3200		

TERMS AND USABLE FORMULAS

The term "head" by itself is rather misleading. It is commonly taken to mean the difference in elevation between the suction level and the discharge level of the liquid being pumped. Although this is partially correct, it does not include all of the conditions that should be included to give an accurate description.

■ **Friction Head:** The pressure expressed in lbs./sq. in. or feet of liquid needed to overcome the resistance to the flow in the pipe and fittings.

■ **Suction Lift:** Exists when the source of supply is below the center line of the pump.

■ **Suction Head:** Exists when the source of supply is above the center line of the pump.

■ **Static Suction Lift:** The vertical distance from the center line of the pump down to the free level of the liquid source.

■ **Static Suction Head:** The vertical distance from the center line of the pump up to the free level of the liquid source.

■ **Static Discharge Head:**

The vertical elevation from the center line of the pump to the point of free discharge.

■ **Dynamic Suction Lift:** Includes static suction lift, friction head loss and velocity head.

■ **Dynamic Suction Head:** Includes static suction head minus friction head minus velocity head.

■ **Dynamic Discharge Head:** Includes static discharge head plus friction head plus velocity head.

■ **Total Dynamic Head:**

Includes the dynamic discharge head plus dynamic suction lift or minus dynamic suction head.

■ **Velocity Head:** The head needed to accelerate the liquid. Knowing the velocity of the liquid, the velocity head loss can be calculated by a simple formula $Head = V^2/2g$ in which g is acceleration due to gravity or 32.16 ft./sec. Although the velocity head loss is a factor in figuring the dynamic heads, the value is usually small and in most cases negligible. See table.

BASIC FORMULAS AND SYMBOLS

Formulas

$$GPM = \frac{Lb./Hr.}{500 \times Sp. Gr.}$$

$$H = \frac{2.31 \times psi}{Sp. Gr.}$$

$$H = \frac{1.134 \times In. Hg.}{Sp. Gr.}$$

$$H_v = \frac{V^2}{2g} = 0.155 V^2$$

$$V = \frac{GPM \times 0.321}{A} = \frac{GPM \times 0.409}{(I.D.)^2}$$

$$BHP = \frac{GPM \times H \times Sp. Gr.}{3960 \times Eff.}$$

$$Eff. = \frac{GPM \times H \times Sp. Gr.}{3960 \times BHP}$$

$$N_s = \frac{N \sqrt{GPM}}{H^{3/4}}$$

$$H = \frac{V^2}{2g}$$

Approximate Cost of Operating Electric Motors

Motor HP	*Average kilowatts input or cost based on 1 cent per kilowatt hour		Motor HP	*Av. kw input or cost per hr. based on 1 cent per kw hour
	1 Phase	3 Phase		3 Phase
1/3	.408		20	16.9
1/2	.535	.520	25	20.8
3/4	.760	.768	30	26.0
1	1.00	.960	40	33.2
1½	1.50	1.41	50	41.3
2	2.00	1.82	60	49.5
3	2.95	2.70	75	61.5
5	4.65	4.50	100	81.5
7½	6.90	6.75	125	102
10	9.30	9.00	150	122
			200	162

Symbols

- GPM** = gallons per minute
- Lb.** = pounds
- Hr.** = hour
- Sp. Gr.** = specific gravity
- H** = head in feet
- psi** = pounds per square inch
- In. Hg.** = inches of mercury
- h_v** = velocity head in feet
- V** = velocity in feet per second

- g** = 32.16 ft./sec.² (acceleration of gravity)
- A** = area in square inches (πr²) (for a circle or pipe)
- ID** = inside diameter in inches
- BHP** = brake horsepower
- Eff.** = pump efficiency expressed as a decimal
- N_s** = specific speed
- N** = speed in revolutions per minute
- D** = impeller in inches

TERMS AND USABLE FORMULAS

BASIC FORMULAS AND SYMBOLS

Temperature conversion
 DEG. C = (DEG. F - 32) x .555
 DEG. F = (DEG. C x 1.8) + 32

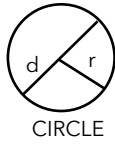

Area of a Circle
 A = area; C = circumference. D = diameter
 $A = \pi r^2$; $\pi = 3.14$ r = radius
 $C = 2\pi r$

Water Horsepower = $\frac{GPM \times 8.33 \times Head}{33000}$ = $\frac{GPM \times Head}{3960}$

Where:
GPM = Gallons per Minute
8.33 = Pounds of water per gallon
33000 = Ft. Lbs. per minute in one horsepower
Head = Difference in energy head in feet (field head).

Laboratory BHP = $\frac{Head \times GPM \times Sp. Gr.}{3960 \times Eff.}$

Where:
GPM = Gallons per Minute
Head = Lab. Head (including column loss)
Eff. = Lab. Eff. of Pump Bowls
Shaft Loss = HP loss due to mechanical friction of lineshaft bearings
Thrust Bearing Loss = HP Loss in driver thrust bearings (See (1) below under Misc.)

Field BHP = Laboratory BHP + Shaft Loss

Total BHP = Field BHP + Thrust Bearing Loss

Input Horsepower = $\frac{Total\ BHP}{Motor\ Eff.}$

Motor Eff. from Motor mfg. (as a decimal)

Field Efficiency = $\frac{Water\ Horsepower}{Total\ BHP}$

Water HP as determined above
Total BHP as determined above

Overall Plant Efficiency = $\frac{Water\ Horsepower}{Input\ Horsepower}$

(See (2) below under Misc.)
Water HP as determined above
Input HP as determined above

Electrical

Input Horsepower = $\frac{BHP}{Mot. Eff.} = \frac{4.826 \times K \times M \times R}{T} = \frac{1.732 \times E \times I \times PF}{746}$

- BHP** = Brake Horsepower as determined above
- Mot. Eff.** = Rated Motor Efficiency
- K** = Power Company Meter Constant
- M** = Power Company Meter Multiplier, or Ratio of Current and Potential Transformers connected with meter
- R** = Revolutions of meter disk
- T** = Time in Sec. for R
- E** = Voltage per Leg applied to motor
- I** = Amperes per Leg applied to motor
- PF** = Power factor of motor
- 1.732** = Factor for 3-phase motors. This reduces to 1 for single phase motors

Kilowatt input to Motor = $.746 \times I.H.P. = \frac{1.732 \times E \times I \times PF}{1000}$ **KW-Hrs. Per 1000 Gallons of Cold Water Pumped Per Hour** = $\frac{HD\ in\ ft. \times 0.00315}{Pump\ Eff. \times Mot. Eff.}$

Miscellaneous

(1) **Thrust Bearing Loss** = .0075 HP per 100 RPM per 1000 lbs. thrust.*
 (2) **Overall Plant Efficiency sometimes referred to as "Wire to Water" Efficiency**
 ***Thrust (in lbs.)** = (thrust constant (k) laboratory head) + (setting in feet x shaft wt. per ft.)
Note: Obtain thrust constant from curve sheets

Discharge Head (in feet of fluid pumped) = $\frac{Discharge\ Pressure\ (psi) \times 2.31}{Sp. Gr. of Fluid Pumped}$

SUMP PUMP TYPICAL INSTALLATIONS

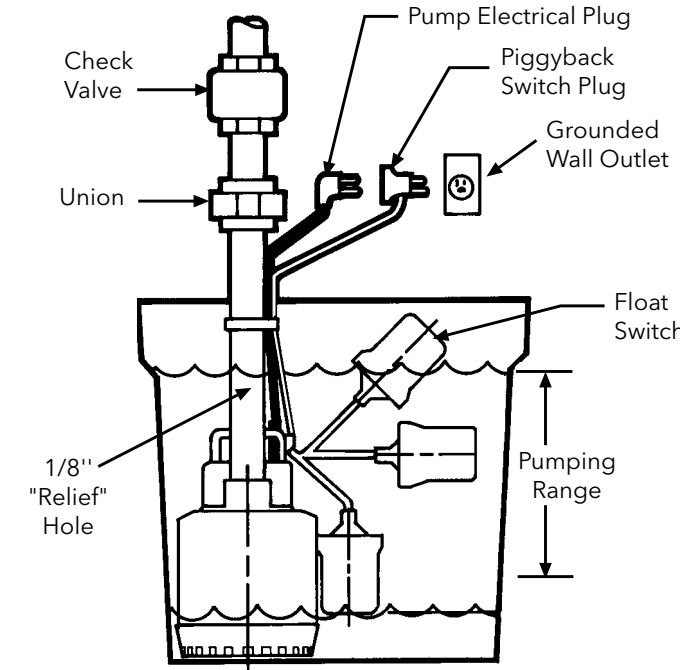

Typical Pump Installation in Sump

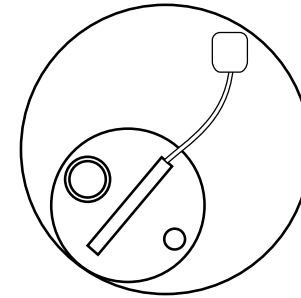
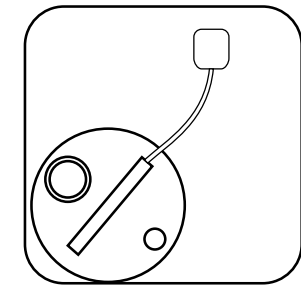

Suggested Pump Positioning in Sump

EFFLUENT AND SEWAGE PUMPS TYPICAL INSTALLATIONS

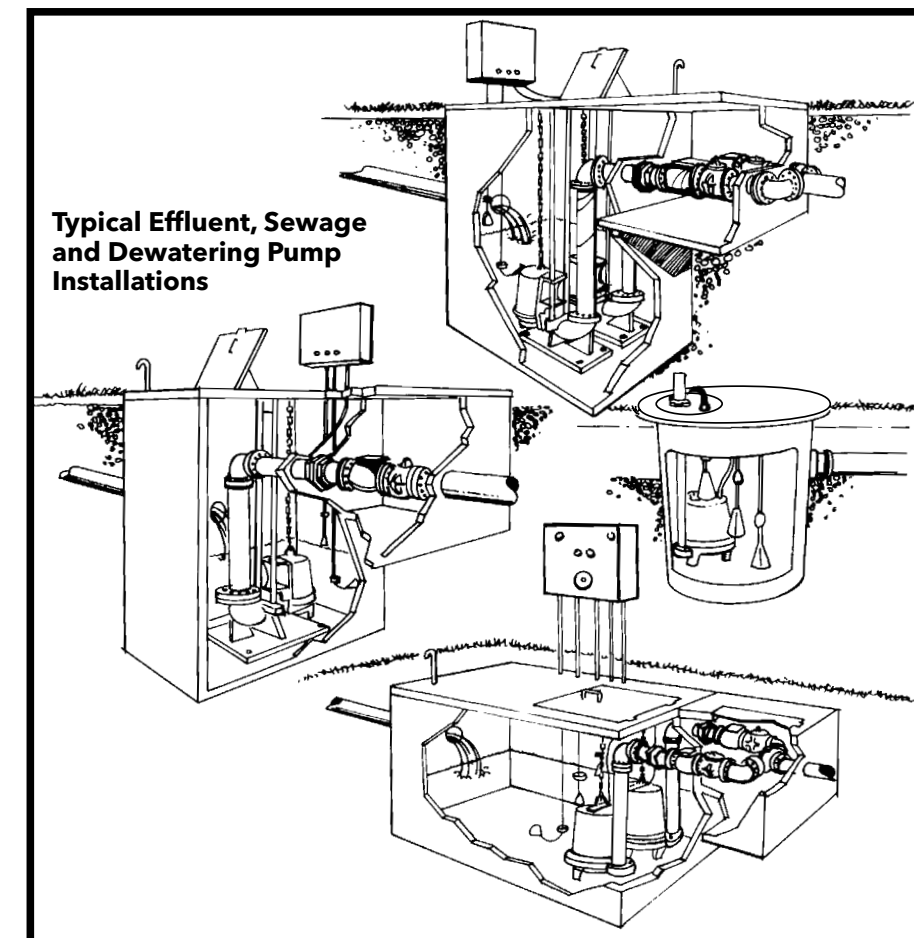

Typical Effluent, Sewage and Dewatering Pump Installations

VARIABLE SPEED DRIVES

WASTEWATER PUMPS AND VARIABLE SPEED DRIVES

It is acceptable and increasingly more common to operate three-phase wastewater pumps using VFD's or variable frequency (speed) drives. We have successfully tested and operated all our premium cast iron construction, three-phase pumps between 30 and 60 hertz operation. The pumps should never be operated below 30 hertz (the VFD must be programmed for a minimum speed of 30 hertz to prevent continuous operation) or above 60 hertz due to increased motor HP loading, higher amperage and the resultant heat rise (see HP in 70 hertz Performance Multipliers).

The "Affinity Laws" state that for a given pump, the capacity will vary directly with a change in speed, the head will vary as the square of the speed change and the required power will vary as the cube of the speed change. (The Affinity Law formulas can be found in the Water Products Technical Manual, TTECHWP). The Performance Multiplier Chart provides shortcut multipliers that eliminate having to solve the Affinity Law equations.

To calculate a pump's total performance range when using a VFD, use the 30 hertz data to create a minimum speed curve, the VFD controlled pump should always be operated between 30 hertz and the published 60 hertz curve. Where it operates at any given moment is irrelevant.

Q_1 , H_1 and BHP_1 are determined at the pump's rated speed N_1 (rpm).

Q_2 , H_2 and BHP_2 are determined at speed N_2 (rpm).

Use the multipliers with a minimum of 3 data points taken from any standard, 60 Hz curve to determine the performance of that pump at a new speed.

Hertz	Performance Multipliers		
70 - $Q_2 = Q_1 \times 1.17$	$H_2 = H_1 \times 1.37$	$BHP_2 = BHP_1 \times 1.6$	
60 - Use the standard published curve data			
50 - $Q_2 = Q_1 \times .83$	$H_2 = H_1 \times .69$	$BHP_2 = BHP_1 \times .57$	
40 - $Q_2 = Q_1 \times .67$	$H_2 = H_1 \times .45$	$BHP_2 = BHP_1 \times .3$	
30 - $Q_2 = Q_1 \times .5$	$H_2 = H_1 \times .25$	$BHP_2 = BHP_1 \times .125$	

An example would be, solve for Q_2 , H_2 and BHP_2 for a 60 Hz pump that produces 100 gpm (Q_1) @ 100' TDH (H_1) using 5 hp (BHP_1) when it is operated at 30 Hz :

Answers: 100 gpm $\times .5 = 50$ gpm, 100' TDH $\times .25 = 25$ ' TDH and 5 hp $\times .125 = .63$ hp.

VFD's save energy while reducing the thrust on the motor bearings and the starting torque on the shaft and impeller.

Contact Customer Service for details, pricing and availability of our full line of VFD products.

STANDARD PANEL SELECTION CHECK LIST

PANEL SIZING

Pump Model Chosen: _____

- Phase: Single _____ Three _____
- Amp draw of pump: _____ (found on bulletin)
- Simplex ("1" Pump) _____ Duplex ("2" Pumps in Pit) _____
- Does pump have a seal fail circuit: yes or no (see note)
(NOTE: If Question 4 is yes, add a seal fail option as noted.)

If Question 1. Single 3. Simplex **use Chart A**

If Question 1. Three 3. Simplex **use Chart B**

If Question 1. Single 3. Duplex **use Chart C**

If Question 1. Three 3. Duplex **use Chart D**

CHART A

Panel Part Number	Amp / Maximum HP	Enclosure
S10020N1 (non-modifiable)	up to 20	Indoor
S10020	up to 20	Indoor/ Outdoor
S12127	21-27	
S12836	28-36	
S1GD2 (includes caps for 1GD,12GDS after 12/2005)	2 HP	
S1FGC2 (use with 1GA/15GDS)	3 HP	
S1FGC3 (use with 1/2GA/15/20GDS)	5.4 HP	
S1FGC5 (use with 2GA/20GDS)	9.4 HP	

Add option H for seal fail circuit to all of the above except S10020N1. Except for GA/GDS grinder pumps, seal fail and high temperature are included in panel.

CHART B

Panel Part Number	Amp / Maximum HP	Enclosure
S31625	1.6-2.5	Indoor / Outdoor
S32540	2.5-4.0	
S34063	4.0-6.3	
S36310	6.3-10	
S31016	10-16	
S31620	16-20	
S32025	20-25	
S32232	22-32	

Add option H for seal fail circuit to all of the above, unless using a GA/GDS pump, use an "O" option.

CHART C

Panel Part Number	Amp / Maximum HP	Enclosure
D10020N1	up to 20	Indoor
D10020	up to 20	Indoor / Outdoor
D12127	21-27	
D12836	28-36	
D1GD2 (includes caps for 1GD,12GDS after 12/2005)	2 HP	
D1FGC2 (use with 1GA / 15GDS)	3 HP	
D1FGC3 (use with 1/2GA / 15/20GDS)	5.4 HP	
D1FGC5 (use with 2GA / 20GDS)	9.4 HP	

Add option J for seal fail circuit to all of the above except D10020N1. Do not add seal fail for GA/GDS grinder pumps, seal fail and high temperature are included in panel.

CHART D

Panel Part Number	Amp / Maximum HP	Enclosure
D31625	1.6-2.5	Indoor / Outdoor
D32540	2.5-4.0	
D34063	4.0-6.3	
D36310	6.3-10	
D31016	10-16	
D31620	16-20	
D32025	20-25	
D32232	22-32	

Add option J for seal fail circuit to all of the above except for GA/GDS pumps, use an Option "P". For other panel options see catalog for adders. For adders not found in the catalog, or more than three options a specification is needed for the Customer Service Department to prepare a quotation. Use of the Custom panel selection sheet is advised with more than three options.

NOTE: Not all models are listed. For more assistance, contact customer service.

DUPLEX SINGLE PHASE WIRING DIAGRAM - D10020

NOTE: The standard panels shown in this book are not designed to be used with pumps requiring external capacitors. See the catalog for panels with built-in capacitor packs.

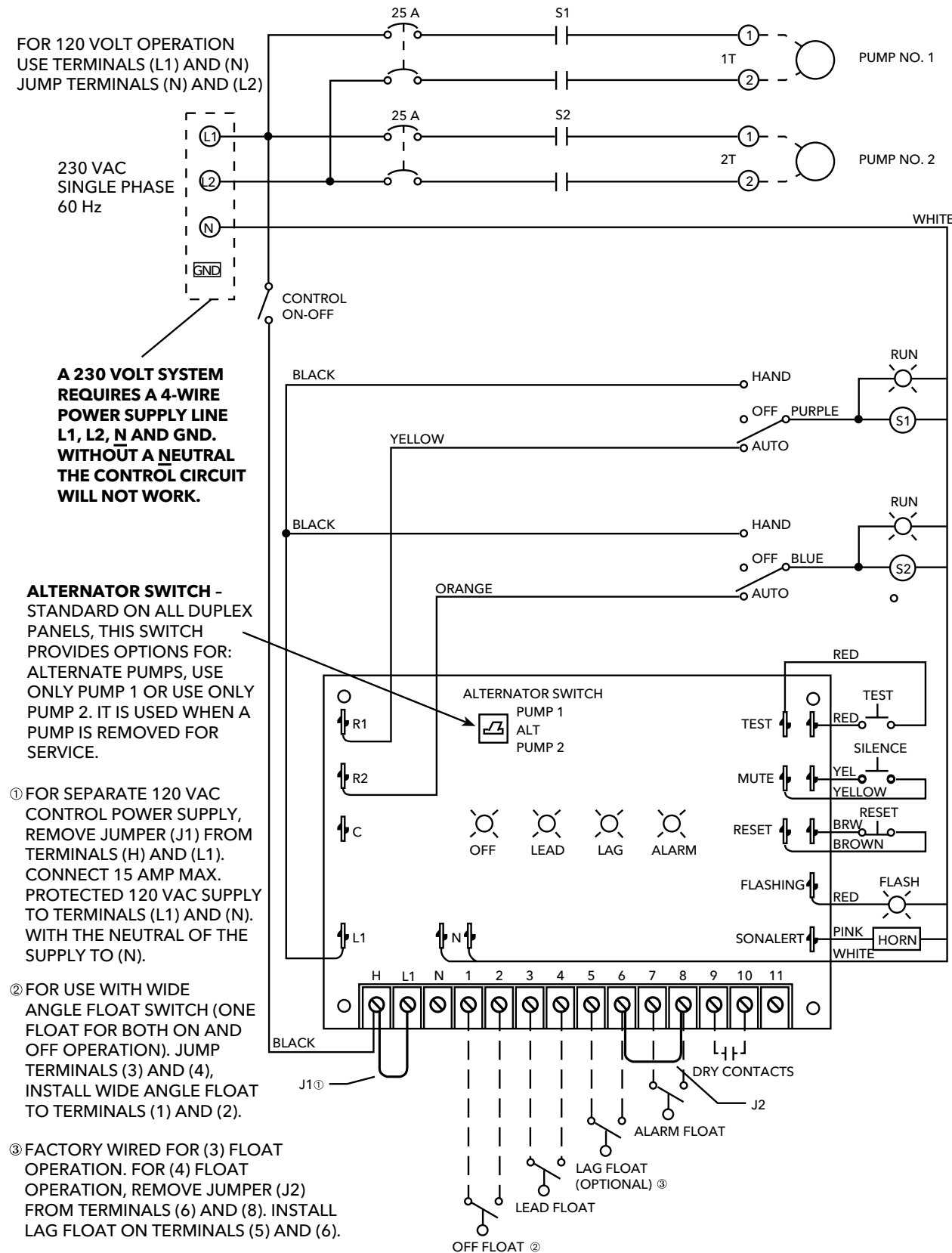

① FOR SEPARATE 120 VAC CONTROL POWER SUPPLY, REMOVE JUMPER (J1) FROM TERMINALS (H) AND (L1). CONNECT 15 AMP MAX. PROTECTED 120 VAC SUPPLY TO TERMINALS (L1) AND (N). WITH THE NEUTRAL OF THE SUPPLY TO (N).

② FOR USE WITH WIDE ANGLE FLOAT SWITCH (ONE FLOAT FOR BOTH ON AND OFF OPERATION). JUMP TERMINALS (3) AND (4), INSTALL WIDE ANGLE FLOAT TO TERMINALS (1) AND (2).

③ FACTORY WIRED FOR (3) FLOAT OPERATION. FOR (4) FLOAT OPERATION, REMOVE JUMPER (J2) FROM TERMINALS (6) AND (8). INSTALL LAG FLOAT ON TERMINALS (5) AND (6).

DUPLEX SINGLE PHASE PANEL LAYOUT - D10020

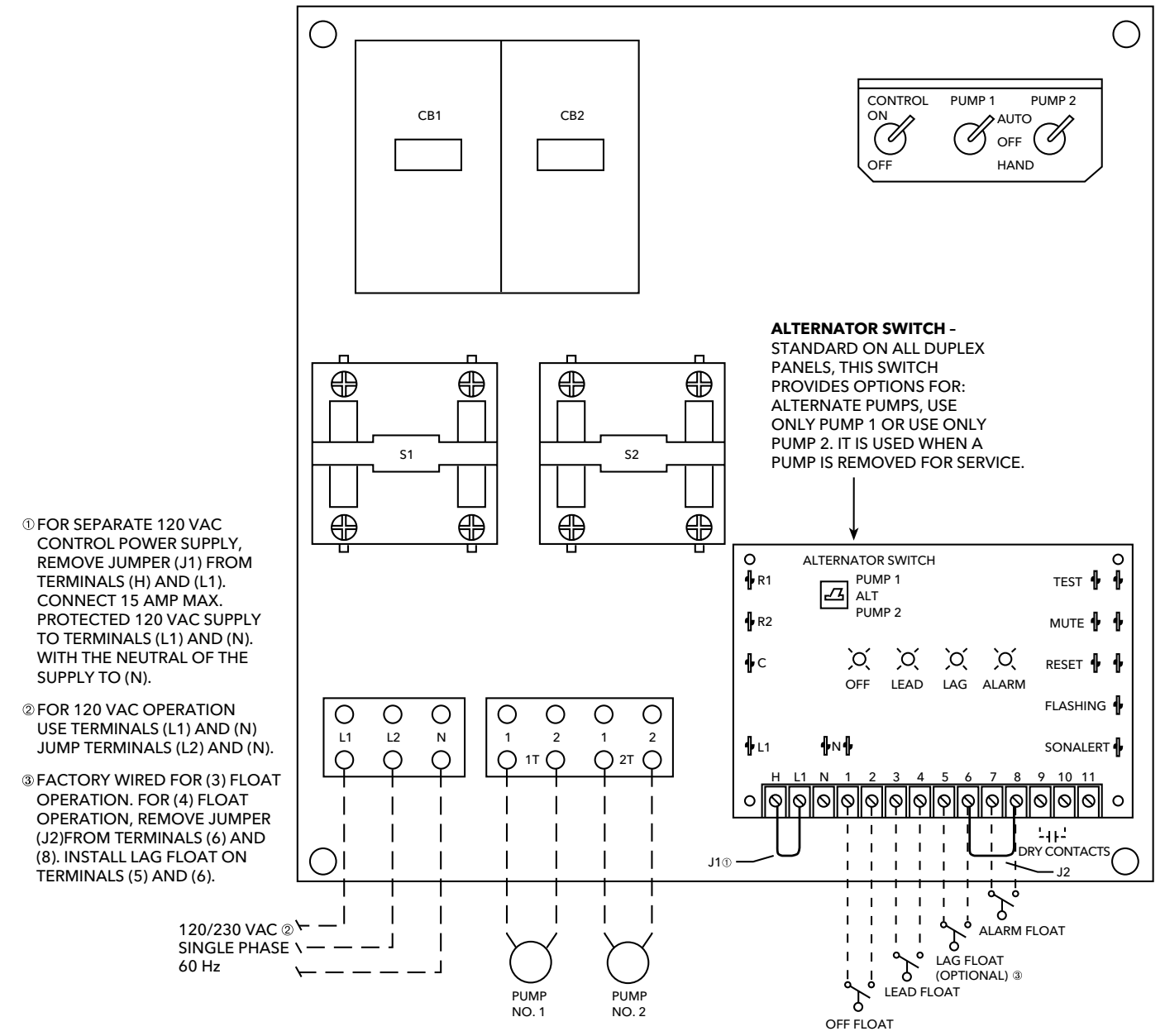

① FOR SEPARATE 120 VAC CONTROL POWER SUPPLY, REMOVE JUMPER (J1) FROM TERMINALS (H) AND (L1). CONNECT 15 AMP MAX. PROTECTED 120 VAC SUPPLY TO TERMINALS (L1) AND (N). WITH THE NEUTRAL OF THE SUPPLY TO (N).

② FOR 120 VAC OPERATION USE TERMINALS (L1) AND (N) JUMP TERMINALS (L2) AND (N).

③ FACTORY WIRED FOR (3) FLOAT OPERATION. FOR (4) FLOAT OPERATION, REMOVE JUMPER (J2) FROM TERMINALS (6) AND (8). INSTALL LAG FLOAT ON TERMINALS (5) AND (6).

NOTE: Panel is not to be used with pumps that do not include capacitors.

DUPLEX THREE PHASE WIRING DIAGRAM - D3 - - - -

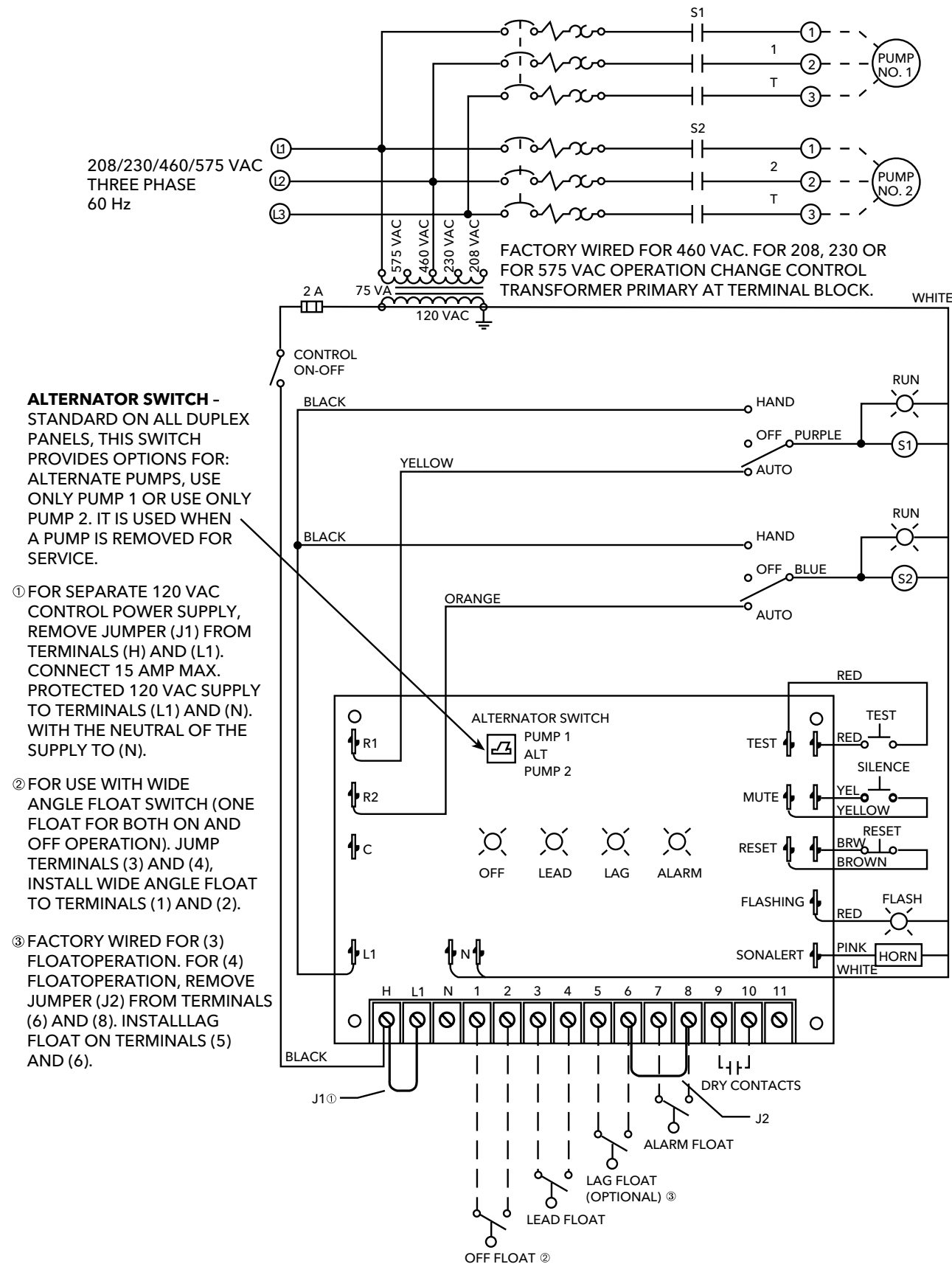

DUPLEX THREE PHASE PANEL LAYOUT - D3 - - - -

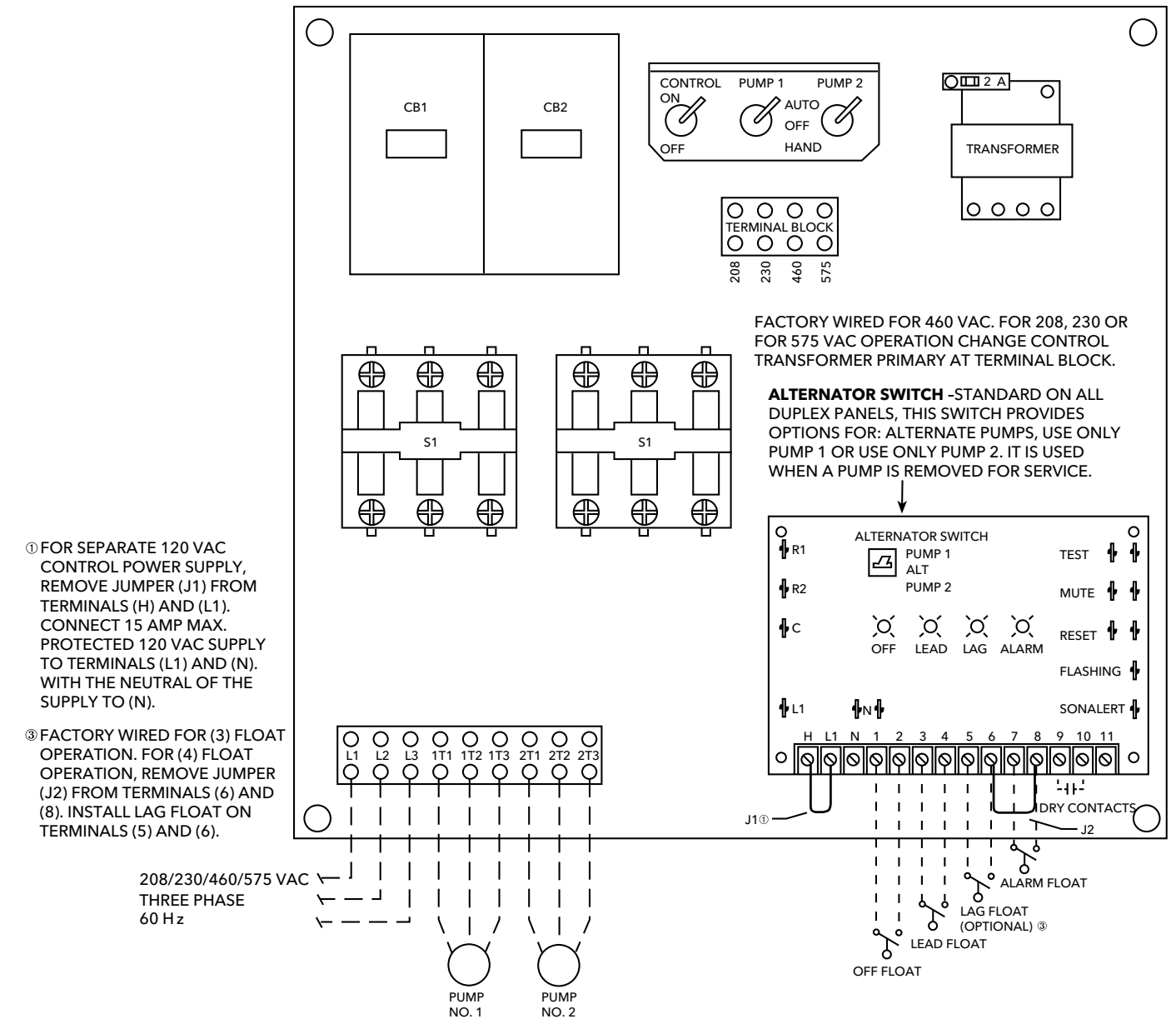

SIMPLEX THREE PHASE PANEL LAYOUT

NOTE: A fused disconnect or circuit breaker must be provided by installer. Provide disconnect sizing per NEC 430-53(C).

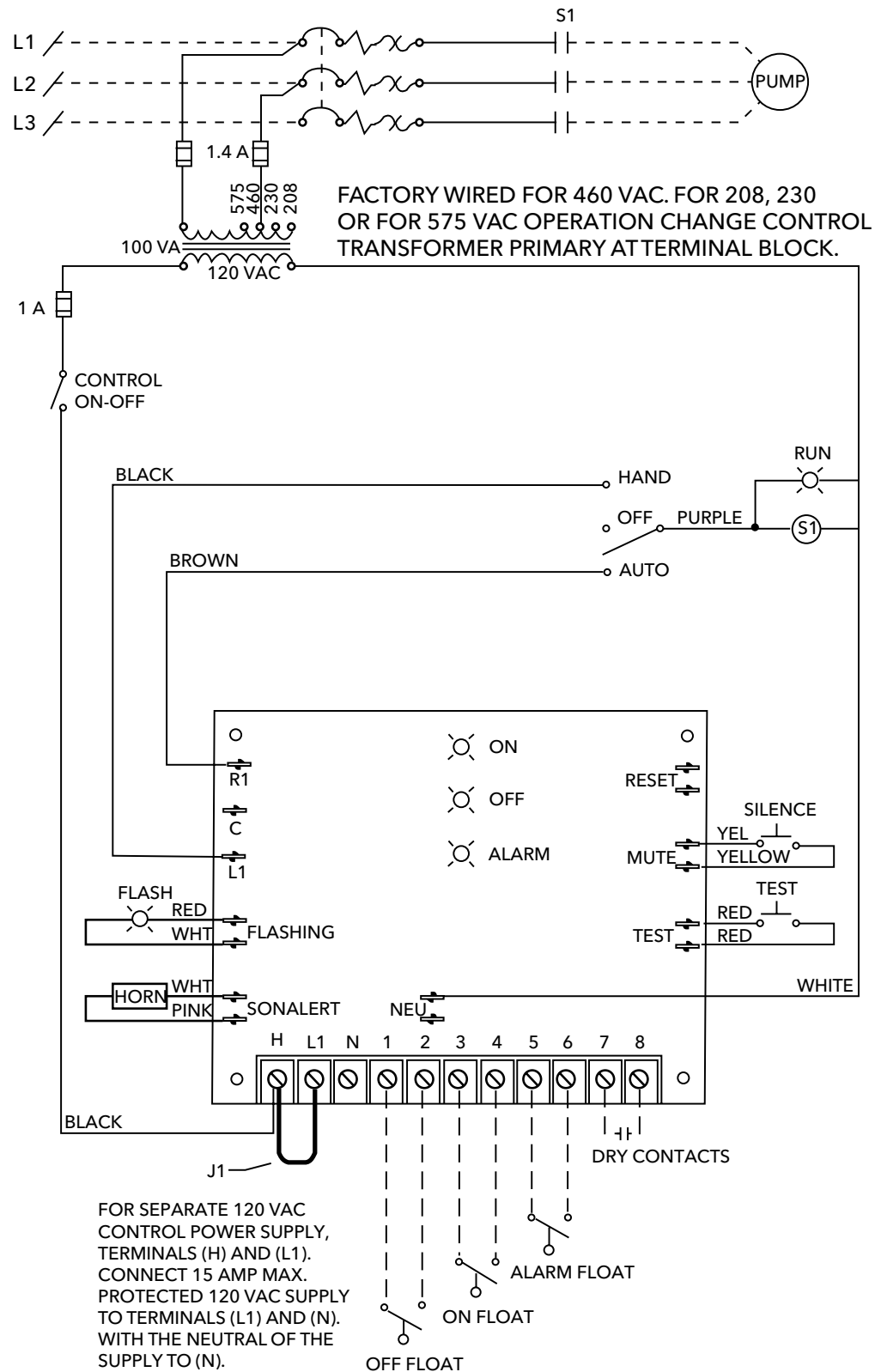

FOR USE WITH WIDE ANGLE FLOAT SWITCH (ONE FLOAT FOR BOTH ON AND OFF OPERATION). JUMP TERMINALS (3) AND (4), INSTALL WIDE ANGLE FLOAT TO TERMINALS (1) AND (2).

SIMPLEX SINGLE PHASE WIRING DIAGRAM - S10020 Before October 1, 2003

NOTE: The standard panels shown in this book are not designed to be used with pumps requiring external capacitors. See the catalog for panels with built-in capacitor packs.

115/230 VAC (FOR 115 VAC, USE TERMINALS L1 AND N, JUMP L2 AND N). SINGLE PHASE, 60 Hz

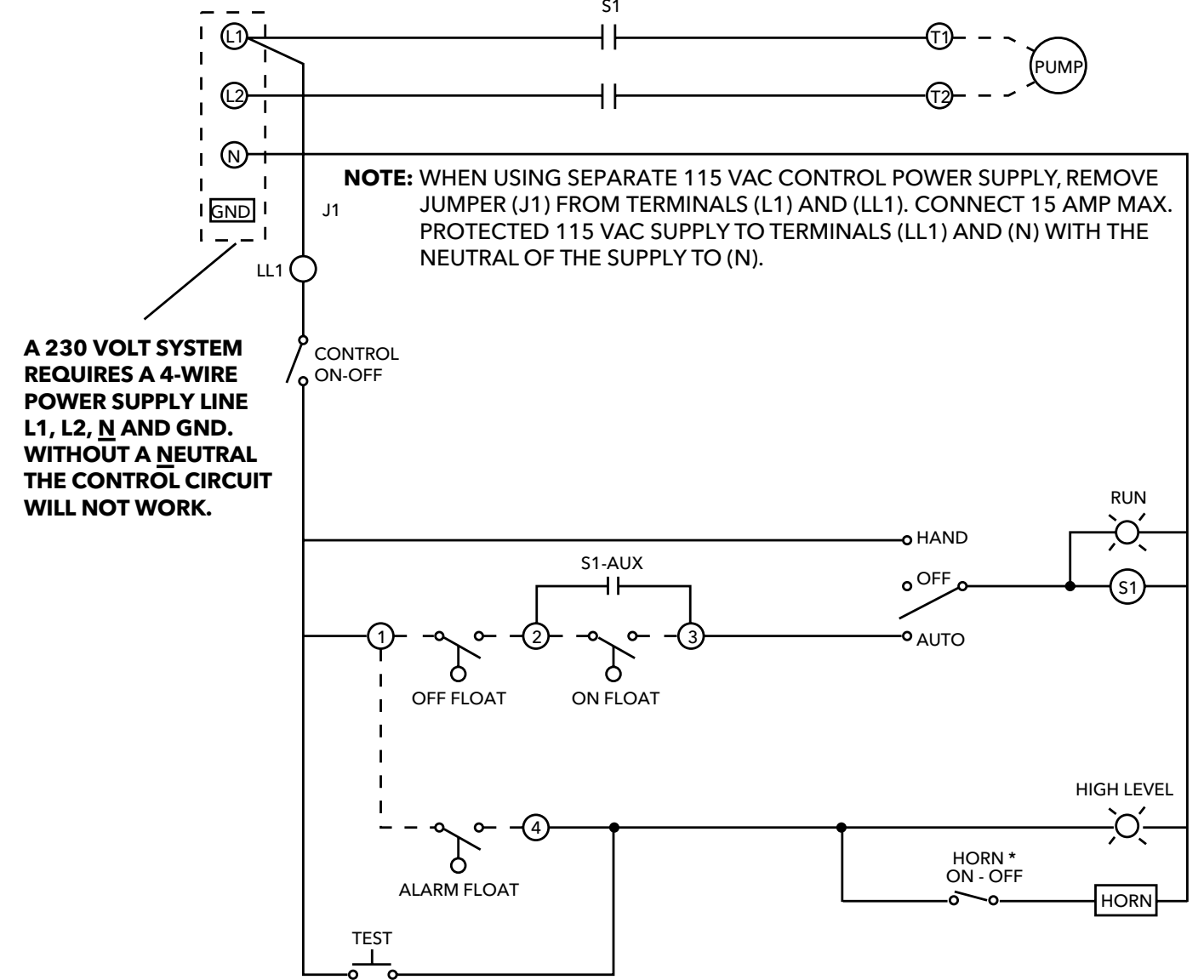

***NOTE:** THE HORN ON/OFF SELECTOR SWITCH MUST BE PLACED BACK INTO THE (ON) POSITION AFTER THE ALARM CONDITION HAS BEEN CORRECTED IN ORDER TO MAINTAIN THE AUDIO ALARM ANNUNCIATION.

SEWAGE CONTROL PANELS AND SWITCHES

There are two basic switches used in sewage and effluent systems. Single-action or narrow-angle float switches perform one function (on or off). They operate over a range of 15°. Wide-angle, or double-action float and diaphragm switches perform two functions (on *and* off). Wide-angle float switches operate over a 90° range and diaphragm switches on a 6" rise in water level.

Control panel wiring diagrams refer to 3 float and 4 float systems, this terminology refers to the use of single-action switches. The following chart shows how many of either type switch to use with different control panels.

Duplex Control Panels

Typical Duplex panels use the following switch set-ups depending on the switch type you use. Most Duplex control panels have a standard high level alarm circuit with a flashing light, most have a horn or bell. Once it turns On - the alarm must be manually reset (turned off) on Duplex panels.

Using a Single-action or Narrow-angle Switch requires:

Three Float Panel Wiring

#1 Bottom	Pumps Off
#2 Middle	1st Pump On
#3 Top	2nd Pump & Alarm On

Four Float Panel Wiring

#1 Bottom	Pumps Off
#2 2nd	1st Pump On
#3 3rd	2nd Pump On
#4 Top	Alarm On

Using Double-Action or Wide-Angle Switches; A2D23W, A2E21, A2E22, A2E23, A2D11, A2D31 or A2S23 requires:

Three Float Panel Wiring

#1 Bottom	1st Pump On/Both Off
#2 Top	2nd Pump and Alarm On

Four Float Panel Wiring

#1 Bottom	1st Pump On/Both Off
#2 Middle	2nd Pump On
#3 Top	Alarm On

Simplex Control Panels

Only some Simplex panels have alarms. This is why the switch quantity requirements vary by simplex panel model. All of our SES panels have high level alarms.

Using a Single-action or Narrow-angle Switch requires:

Simplex Panel with Alarm

#1 Bottom	Pump Off
#2 Middle	Pump On
#3 Top	Alarm On/Off

Simplex Panel with No Alarm

#1 Bottom	Pump Off
#2 Top	Pump On

Using Double-Action or Wide-angle Switches requires:

Simplex Panel with Alarm

#1 Bottom	Pump On/Off
#2 Top	Alarm On/Off

Simplex Panel with No Alarm

#1 Bottom	Pump On/Off
-----------	-------------

NOTE: 1st pump may also be referred to as "Lead" pump, 2nd pump may be called "Lag" pump.

We sell and stock a complete line of wastewater float switches. The most up-to-date information is found in the *Pump/Control/Panel Switches Technical Brochure (BCPFS)* found at www.xylem.com/BCPFS.

NOTES

NOTES

Xylem |'zīləm|

- 1) The tissue in plants that brings water upward from the roots;
- 2) a leading global water technology company.

We're a global team unified in a common purpose: creating advanced technology solutions to the world's water challenges. Developing new technologies that will improve the way water is used, conserved, and re-used in the future is central to our work. Our products and services move, treat, analyze, monitor and return water to the environment, in public utility, industrial, residential and commercial building services settings. Xylem also provides a leading portfolio of smart metering, network technologies and advanced analytics solutions for water, electric and gas utilities. In more than 150 countries, we have strong, long-standing relationships with customers who know us for our powerful combination of leading product brands and applications expertise with a strong focus on developing comprehensive, sustainable solutions.

For more information on how Xylem can help you, go to www.xylem.com



Xylem Inc.
2881 East Bayard Street Ext., Suite A
Seneca Falls, NY 13148
Phone: (866) 325-4210
Fax: (888) 322-5877
www.xylem.com

Xylem, Bell & Gossett, Red Jacket Water Products and CentriPro are trademarks or registered trademarks of Xylem Inc. or one of its subsidiaries. Goulds is a registered trademark of ITT Manufacturing Enterprises LLC and is used under license. All other trademarks or registered trademarks are property of their respective owners.
© 2023 Xylem Inc. TTECHS R6 June 2023