

Model e-SH

Close coupled & frame mounted end
suction pumps

Table of Contents

1	Introduction and Safety.....	2
1.1	Introduction.....	2
1.2	Safety.....	2
1.2.1	Safety terminology and symbols.....	2
1.2.2	User safety.....	3
1.2.3	Protecting the environment.....	4
2	Transportation and Storage.....	5
2.1	Examine the delivery.....	5
2.1.1	Examine the package.....	5
2.1.2	Examine the unit.....	5
2.2	Safe handling requirements.....	5
2.2.1	Long-term storage.....	5
3	Product Description.....	6
3.1	General description.....	6
3.2	Operational specifications.....	6
4	Installation.....	8
4.1	Preinstallation.....	8
4.1.1	Pump location guidelines.....	8
4.1.2	Typical installation.....	8
4.1.3	Foundation requirements.....	8
4.1.4	Grout the baseplate.....	9
4.1.5	Piping checklist.....	9
4.1.6	Connect the piping to the pump.....	10
4.2	Alignment checks.....	10
4.3	Perform alignment.....	11
4.4	Final alignment.....	12
5	Operation.....	13
5.1	Precautions.....	13
5.2	Suction piping.....	13
5.3	Discharge piping.....	14
5.4	Check the rotation.....	14
5.5	Operation checks.....	14
6	Maintenance.....	15
6.1	Bearing maintenance.....	15
6.2	Disassemble the pump.....	15
6.3	Reassemble the pump.....	16
7	Troubleshooting.....	17
7.1	Operation troubleshooting.....	17
8	Product Warranty.....	19

1 Introduction and Safety

1.1 Introduction

Purpose of this manual

The purpose of this manual is to provide necessary information for:

- Installation
- Operation
- Maintenance



CAUTION:

Read this manual carefully before installing and using the product. Improper use of the product can cause personal injury and damage to property, and may void the warranty.

NOTICE:

Save this manual for future reference, and keep it readily available at the location of the unit.

1.2 Safety



WARNING:

- The operator must be aware of safety precautions to prevent physical injury.
- Operating, installing, or maintaining the unit in any way that is not covered in this manual could cause death, serious personal injury, or damage to the equipment. This includes any modification to the equipment or use of parts not provided by Xylem. If there is a question regarding the intended use of the equipment, please contact a Xylem representative before proceeding.
- Do not change the service application without the approval of an authorized Xylem representative.



CAUTION:

You must observe the instructions contained in this manual. Failure to do so could result in physical injury, damage, or delays.

1.2.1 Safety terminology and symbols



About safety messages

It is extremely important that you read, understand, and follow the safety messages and regulations carefully before handling the product. They are published to help prevent these hazards:

- Personal accidents and health problems
- Damage to the product and its surroundings
- Product malfunction



Hazard levels

Hazard level	Indication
 DANGER:	A hazardous situation which, if not avoided, will result in death or serious injury

Hazard level	Indication
 WARNING:	A hazardous situation which, if not avoided, could result in death or serious injury
 CAUTION:	A hazardous situation which, if not avoided, could result in minor or moderate injury
NOTICE:	Notices are used when there is a risk of equipment damage or decreased performance, but not personal injury.

Special symbols

Some hazard categories have specific symbols, as shown in the following table.

Electrical hazard	Magnetic fields hazard
 Electrical Hazard:	 CAUTION:

1.2.2 User safety

General safety rules

These safety rules apply:

- Always keep the work area clean.
- Pay attention to the risks presented by gas and vapors in the work area.
- Avoid all electrical dangers. Pay attention to the risks of electric shock or arc flash hazards.
- Always bear in mind the risk of drowning, electrical accidents, and burn injuries.

Safety equipment

Use safety equipment according to the company regulations. Use this safety equipment within the work area:

- Hard hat
- Safety goggles, preferably with side shields
- Protective shoes
- Protective gloves
- Gas mask
- Hearing protection
- First-aid kit
- Safety devices

NOTICE:

Never operate a unit unless safety devices are installed. Also see specific information about safety devices in other chapters of this manual.

Electrical connections

Electrical connections must be made by certified electricians in compliance with all international, national, state, and local regulations. For more information about requirements, see sections dealing specifically with electrical connections.

Precautions before work

Observe these safety precautions before you work with the product or are in connection with the product:

- Provide a suitable barrier around the work area, for example, a guard rail.
- Make sure that all safety guards are in place and secure.
- Make sure that you have a clear path of retreat.
- Make sure that the product cannot roll or fall over and injure people or damage property.
- Make sure that the lifting equipment is in good condition.
- Use a lifting harness, a safety line, and a breathing device as required.
- Allow all system and pump components to cool before you handle them.
- Make sure that the product has been thoroughly cleaned.
- Disconnect and lock out power before you service the pump.
- Check the explosion risk before you weld or use electric hand tools.

1.2.2.1 Wash the skin and eyes

Follow these procedures for chemicals or hazardous fluids that have come into contact with your eyes or your skin:

Condition	Action
Chemicals or hazardous fluids in eyes	<ol style="list-style-type: none"> 1. Hold your eyelids apart forcibly with your fingers. 2. Rinse the eyes with eyewash or running water for at least 15 minutes. 3. Seek medical attention.
Chemicals or hazardous fluids on skin	<ol style="list-style-type: none"> 1. Remove contaminated clothing. 2. Wash the skin with soap and water for at least 1 minute. 3. Seek medical attention, if necessary.

1.2.3 Protecting the environment

Emissions and waste disposal

Observe the local regulations and codes regarding:

- Reporting of emissions to the appropriate authorities
- Sorting, recycling and disposal of solid or liquid waste
- Clean-up of spills

Exceptional sites



CAUTION: Radiation Hazard

Do NOT send the product to Xylem if it has been exposed to nuclear radiation, unless Xylem has been informed and appropriate actions have been agreed upon.

Recycling guidelines

Always follow local laws and regulations regarding recycling.

2 Transportation and Storage

This an test example.

2.1 Examine the delivery

2.1.1 Examine the package

1. Examine the package for damaged or missing items upon delivery.
2. Record any damaged or missing items on the receipt and freight bill.
3. If anything is out of order, then file a claim with the shipping company.
If the product has been picked up at a distributor, make a claim directly to the distributor.

2.1.2 Examine the unit

1. Remove packing materials from the product.
Dispose of all packing materials in accordance with local regulations.
2. To determine whether any parts have been damaged or are missing, examine the product.
3. If applicable, unfasten the product by removing any screws, bolts, or straps.
Use care around nails and straps.
4. If there is any issue, then contact a sales representative.

2.2 Safe handling requirements



WARNING:

- Personal protective equipment should be worn when handling this equipment.
 - Transportation & installation of this equipment should only be performed by qualified personnel.
 - A professional rigging company should be consulted before lifting the pump assembly.
 - Only use properly sized, certified lifting equipment & lifting devices, including slings, suitably rated for the weights to be lifted.
 - Slings, when used, must be of identical materials to avoid differences in stretch rates.
 - Do not use lifting devices that are frayed, kinked, unmarked, or worn.
 - Lifting eyebolts fitted on single components of the assembly (pump or motor) must not be used to lift the complete assembly.
 - Failure to observe these instructions could result in equipment or property damage, serious injury, or death.
-

2.2.1 Long-term storage

If the unit is stored for more than 6 months, these requirements apply:

- Store in a covered and dry location.
- Store the unit free from heat, dirt, and vibrations.
- Rotate the shaft by hand several times at least every three months.

For questions about possible long-term storage treatment services, please contact your local sales and service representative.

3 Product Description

3.1 General description

The pump is a centrifugal, close-coupled pump. These features make the pump easy to install, operate, and service:

- AISI Type 316 L stainless steel pump parts for decreased corrosion and improved strength and ductility
- Flexible installation and driver arrangements
- Back pull-out design simplifies maintenance when used with spacer type coupling
- Cast iron power frame; Rigidly supported, grease lubricated ball bearing assembly
- Standard John Crane Type 21 mechanical seal
- Standard NEMA design T-frame or JM frame motors in single or three phase
- Suction and discharge flanges: mate with ANSI class 150 flanges
- Compact design saves space and simplifies maintenance.
- NSF 61 certification

Intended applications

NOTICE:

This product can expose you to chemicals including Lead, which is known to the State of California to cause cancer and birth defects or other reproductive harm. For more information go to: www.P65Warnings.ca.gov.

This product is designed for all traditional cast iron or bronze fitted water and low grade corrosive services.

- Water circulation
- Booster systems
- Liquid transfer
- HVAC pump replacements
- General service pumping

3.2 Operational specifications

Capacity	1100 gpm (250 m ³ /hr) at 3500 rpm 775 gpm (177 m ³ /hr) at 1750 rpm
Head	525 feet THD (158 m) at 3500 rpm 130 feet THD (40 m) at 1750 rpm
Maximum working pressure	230 psi (15 bars)
Maximum temperature	250°F (121°C)
All wetted components of AISI	Type 316 L stainless steel material
Rotation	Clockwise when viewed from motor end
Enclosed impeller and replaceable wear ring	High efficiency and maximum wear life

Motor (close coupled)

NEMA standard JM shaft open drip-proof*, totally enclosed* and explosion-proof enclosures*, 60 Hz, 1750 rpm, or 3500 rpm

- Single phase ODP* (115/230 V) 1750 rpm, 1–5 hp
- Three phase ODP* TEFC*/ explosion-proof* (208–230/460 V)
 - 3500 rpm, 2–100 hp
 - 1750 rpm, 1–25 hp

NOTE: Overload protection must be provided. Contactor with overload for single phase or started with heaters for three phase ordered separately.

Motor (frame mounted)

NEMA standard T-frame open drip-proof*, totally enclosed*, and explosion-proof (three phase only) enclosures*, 60 Hz, 1750 rpm, or 3500 rpm

- Single phase (115/230 V) 1750 rpm, 1–5 hp
- Three phase (208–230/460 V)
 - 3500 rpm, 3–125 hp
 - 1750 rpm, 1–25 hp

NOTE: Overload protection must be provided. Contactor with overload for single phase or starter with heaters for three phase ordered separately.

Optional: Rigid carbon steel bedplate, sheet metal coupling guard designed to OSHA specifications and T.B. Woods type “SC” spacer couplings.

* Premium efficiency where required by Department of Energy regulations

4 Installation

4.1 Preinstallation

4.1.1 Pump location guidelines

WARNING:

The installation of the pump shall include adequate drainage or located such that other equipment or property would not be damaged in the event of any leakage. The pump should not be installed above equipment or property unless adequate drainage is provided. Failure to comply with this warning could result in property damage.

WARNING:

Overtightening of the casing fasteners could damage the fastener, resulting in leakage and property damage.

WARNING:

Assembled units and their components are heavy. Failure to properly lift and support this equipment can result in serious physical injury and/or equipment damage. Lift equipment only at the specifically identified lifting points. Lifting devices such as eyebolts, slings, and spreaders must be rated, selected, and used for the entire load being lifted.

CAUTION:

Do not install with motor below pump. Condensation will build up in motor.

Guideline	Explanation/comment
Close-coupled units can be installed inclined or vertical.	
Keep the pump as close to the liquid source as practically possible and below the liquid level for automatic operation.	This minimizes the friction loss and keeps the suction piping as short as possible.
Protect the unit from weather and water damage due to rain, flooding, and freezing temperatures.	This is applicable if nothing else is specified.
Make sure that the space around the pump is sufficient.	This facilitates ventilation, inspection, maintenance, and service.
Never draw piping into place by forcing the pump suction and discharge connections.	All piping must be supported independently of the pump and must line up naturally.
Take into consideration the occurrence of unwanted noise and vibration.	The best pump location for noise and vibration absorption is on a concrete floor with subsoil underneath.

4.1.2 Typical installation

4.1.3 Foundation requirements

- Close-coupled units:
 - The foundation must be flat and substantial to eliminate strain when tightening bolts.
 - Use rubber mounts to minimize noise and vibration.
 - Tighten motor hold-down bolts before connecting piping to pump.
- Frame-mounted pumps:

- Permanent and solid foundation is required for smooth operation.
- Bedplate must be grouted to a foundation with solid footings.

4.1.4 Grout the baseplate

Required equipment:

- Cleaners: Do not use an oil-based cleaner because the grout will not bond to it. See the instructions provided by the grout manufacturer.
 - Grout: Non-shrink grout is recommended.
1. Place unit in position on wedges located at four points, two below approximate center of the driver and two below approximate center of the pump.
 2. Adjust wedges to level the unit, brining coupling halves into reasonable alignment.
 3. Level or plumb suction and discharge flanges.
 4. Make sure baseplate is not distorted and final coupling alignment can be made within the limits of movement of the motor and by shimming if necessary.
 5. Tighten foundation bolts finger tight.
 6. Clean all the areas of the baseplate that will come into contact with the grout.
 7. Build a dam around the foundation.
 8. Thoroughly wet the foundation that will come into contact with the grout.
 9. Pour grout under baseplate, making sure the areas under the pump and motor feet are filled solid.

Locate shims to allow removal after grouting.

When you pour the grout, remove air bubbles from it by using one of these methods:

- Puddle with a vibrator.
- Pump the grout into place.

10. Allow the grout to harden for 48 hours before further tightening foundation bolts.
11. After the grout has dried, check the foundation bolts and tighten if necessary. Check alignment after tightening the bolts.

4.1.5 Piping checklist



WARNING:

- The heating of water and other fluids causes volumetric expansion. The associated forces can cause the failure of system components and the release of high-temperature fluids. In order to prevent this, install properly sized and located compression tanks and pressure-relief valves. Failure to follow these instructions can result in serious personal injury or death, or property damage.
- Avoid serious personal injury and property damage. Make sure that the flange bolts are adequately torqued.

NOTICE:

Never force piping to make a connection with a pump.

Check	Explanation/comment	Checked
Check that the pump is not supported by placing hangers or floor supports on the motor.	Shaft misalignment and subsequent premature coupling and bearing wear will result if motor is improperly supported.	
Check that a section of straight pipe, with a length that is five times its diameter, is installed between the suction side of the pump and the first elbow, or that a B&G Suction Diffuser is installed.	This reduces suction turbulence by straightening the flow of liquid before it enters the pump.	

Check	Explanation/comment	Checked
Check that a section of straight pipe, with a length that is five times its diameter, is installed between the suction side of the pump and the first elbow.	This reduces suction turbulence by straightening the flow of liquid before it enters the pump.	
Check that a section of straight pipe, with a length that is a minimum of five times its diameter, is installed between the suction side of the pump and the first elbow.	This reduces suction turbulence by straightening the flow of liquid before it enters the pump.	
Check that the suction and discharge pipes are supported independently by use of pipe hangers near the pump .	This eliminates pipe strain on the pump .	
Check that there is a strong, rigid support for the suction and discharge lines.	As a rule, ordinary wire or band hangers are not adequate to maintain proper alignment.	
For pumps with flanges, check that the bolt holes in the pump flanges match the bolt holes in the pipe flanges.	—	
For pumps mounted in vertical piping with the motor in the horizontal position, check that adequate support is provided.	This prevents strain on the pump parts and piping. Do not mount the pump with the motor vertically downward. Do not use motor lift rings to suspend the pump.	
Check that the suction or discharge lines are not forced into position.	Coupling and bearing wear will result if suction or discharge lines are forced into position.	
Check that fittings for absorbing expansion are installed in the system when considerable temperature changes are expected.	This helps to avoid strain on the pump.	
Check that the pipeline has isolation valves around the pump and has a drain valve in the suction pipe.	—	
Use PTFE tape sealer or a high quality thread sealant when you install the suction and discharge connections to a threaded pump housing.	—	

4.1.6 Connect the piping to the pump

1. On frame-mounted units, tighten foundation, pump, and driver hold-down bolts before connecting piping to pump.
2. After completing piping, rotate unit by hand to check for binding.
A screwdriver slot or flats are provided in the end of the motor shaft.

4.2 Alignment checks

When to perform alignment checks

You must perform alignment checks under these circumstances:

- The process temperature changes.
- The piping changes.
- The pump has been serviced.

Types of alignment checks

Type of check	When it is used
Initial alignment (cold alignment) check	Prior to operation when the pump and the driver are at ambient temperature.

Type of check	When it is used
Final alignment (hot alignment) check	After operation when the pump and the driver are at operating temperature.

Initial alignment (cold alignment) checks

When	Why
After you connect the piping	This ensures that pipe strains have not altered the alignment.

Final alignment (hot alignment) checks

When	Why
After the first run	This ensures correct alignment when both the pump and the driver are at operating temperature.
Periodically	This follows the plant operating procedures.

4.3 Perform alignment

- No field alignment is necessary on close-coupled pumps.
- Even though the pump-motor unit may have a factory alignment, in transit this alignment could be disturbed and must be checked prior to running.
- Angular alignment of the flanges can best be accomplished using calipers at bolt locations.

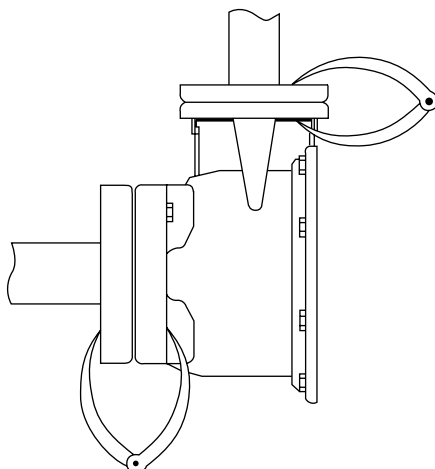

1. Check the tightness of all hold-down bolts before checking the alignment.
2. If realignment is necessary, always move the motor. Shim as required.
3. Final alignment is achieved when parallel and angular requirements are achieved with both pump and motor hold-down bolts tight.



CAUTION:

Always recheck both alignments after making adjustments.

4. Parallel misalignment exists when the shafts are not concentric.
 - a) Place dial indicator on one hub and rotate this hub 360° while taking readings on the outside diameter of the other hub.

Parallel alignment occurs when Total Indicator Reading is .005" or less.
5. Angular misalignment exists when the shafts are not parallel.
 - a) Place dial indicator on one hub and rotate this hub 360° while taking readings on the face of the other hub.

Angular alignment is achieved when Total Indicator Reading is .005" or less.

4.4 Final alignment

Final alignment is achieved when parallel and angular requirements are achieved with both pump and motor hold down bolts tight.

5 Operation

5.1 Precautions



WARNING:

- Make sure that the drained liquid does not cause damage or injuries.
 - The motor protectors can cause the motor to restart unexpectedly. This could result in serious injury.
 - Never operate the pump without the coupling guard correctly installed.
-



CAUTION:

- The outer surfaces of the pump and motor can exceed 104°F (40°C) during operation. Do not touch with any part of the body without protective gear.
 - Do not put any combustible material near the pump.
-

NOTICE:

- Never operate the pump below the minimum rated flow, when dry, or without prime.
 - Never operate the pump with the delivery ON-OFF valve closed for longer than a few seconds.
 - Never operate the pump with the suction ON-OFF valve closed.
 - Do not expose an idle pump to freezing conditions. Drain all liquid that is inside the pump. Failure to do so can cause liquid to freeze and damage the pump.
 - The sum of the pressure on the suction side (mains, gravity tank) and the maximum pressure that is delivered by the pump must not exceed the maximum working pressure that is allowed (nominal pressure PN) for the pump.
 - Do not use the pump if cavitation occurs. Cavitation can damage the internal components.
-

5.2 Suction piping

1. Low static lift and short, direct suction piping is desired. For suction lift over 15 feet, consult pump performance curve for Net Positive Suction Head Required.
2. Suction pipe size must be at least equal to suction connection of pump.
3. If larger pipe is used, an eccentric pipe reducer (with straight side up) must be used at the pump.
4. Installation with pump below source of supply:
 - a. Install isolation valve in piping for inspection and maintenance.
 - b. Do not use suction isolation valve to throttle pump.
5. Installation with pump above source of supply:
 - a. To avoid air pockets, no part of piping should be higher than pump suction connection. Slope piping upwards from liquid source.
 - b. All joints must be airtight.
 - c. Foot valve to be used only if necessary for priming, or to hold prime on intermittent service.
 - d. Suction strainer open area must be at least triple the pipe area.
6. Size of inlet from liquid source, and minimum submergence over inlet, must be sufficient to prevent air entering pump.

5.3 Discharge piping

1. Arrangement must include a check valve located between a gate valve and the pump. The gate valve is for regulation of capacity, or inspection of pump or check valve.
2. If reducer is required, place between check valve and pump.

5.4 Check the rotation



WARNING:

Do not place hands in pump while checking motor rotation. To do so will cause severe personal injury.

1. Pumps are right-hand rotation (Clockwise when viewed from the driver end).
 - a) Switch power on and off.
 - b) Observe shaft rotation.
 - c) On frame-mounted units, check rotation before coupling pump to motor.
2. Single-Phase: Refer to wiring diagram on motor if rotation must be changed.
3. Three-Phase: Interchange any two power supply leads to change rotation.

5.5 Operation checks



CAUTION:

Pumped liquid provides lubrication. If pump is run dry, rotating parts will seize and mechanical seal will be damaged.

1. Before starting, pump must be primed (free of air and suction pipe full of liquid) and discharge valve partially open.
2. Make complete check after unit is run under operating conditions and temperature has stabilized. Check for expansion of piping. Check coupling alignment.
3. Do not operate at or near zero flow. Energy imparted to the liquid is converted into heat. Liquid may flash to vapor. Rotating parts require liquid to prevent scoring or seizing.

6 Maintenance

Precautions



Electrical Hazard:

Disconnect and lock out electrical power before installing or servicing the unit.



WARNING:

- Maintenance and service must be performed by skilled and qualified personnel only.
 - Observe accident prevention regulations in force.
 - Use suitable equipment and protection.
 - Make sure that the drained liquid does not cause damage or injuries.
-

6.1 Bearing maintenance

- For close coupled units bearings are located in and are part of the motor. For lubrication procedure, refer to the manufacturer's instructions.
- On frame-mounted units (M-group only), regrease at 2,000 hours use or after three months. Use #2 Sodium or Lithium grease and fill until grease comes out of the relief fitting.
- On frame-mounted units (S-group only), bearings are greased for life as outlined in S-group power frame repair parts (RSPFRAME).

6.2 Disassemble the pump

1. Drain system. Flush if necessary.
2. Remove the motor hold-down bolts on close-coupled or disconnect coupling and remove the spacer.
3. Remove casing bolts and pump hold-down bolts.
4. Remove the motor and rotating element from casing.
5. Unscrew the impeller bolt with a socket wrench. **Do not insert a screwdriver between impeller vanes to prevent rotation.**
It may be necessary to use a strap wrench around the impeller if impacting the socket wrench will not loosen the impeller bolt.
6. Remove impeller O-ring.
7. Insert two pry bars (180° apart) between impeller and seal housing. Pry off impeller.
8. Remove shaft sleeve, seal spring, cupwasher, seal rotary, and impeller key.
9. Remove seal housing.
10. Place seal housing on a flat surface. Press out stationary seal parts.
11. Remove the deflector from the shaft on frame-mounted units.
12. Remove bolts holding bearing cover to frame and remove bearing cover (frame-mount).
13. Remove V-rings (S-Group) or lip seals (M-Group) from the bearing frame and the bearing cover (frame-mount).
14. Remove shaft and bearings from frame (frame-mount).
15. Remove bearing retaining ring (frame-mount).
16. Use bearing puller or arbor press to remove ball bearings (frame-mount).
17. Remove wear ring if excessively worn. Use pry bar and/or vicegrips.

6.3 Reassemble the pump

1. Clean all parts before reassembly.
2. Refer to parts list to identify required replacement items.
Reassembly is the reverse of the disassembly procedure.
3. Replace V-rings (S-Group) or lip seals (M-Group) if worn or damaged (frame-mount only).
4. Replace ball bearings if loose, rough, or noisy when rotated (frame-mount only).
5. Check the shaft for maximum runout of 0.005" TIR. Bearing seats and lip seal areas must be smooth and free of scratches or grooves. Replace if necessary (frame-mount only).
6. All mechanical seal components must be in good condition or leakage may result. Replacement of complete seal assembly, whenever seal has been removed, is good standard practice.
7. If wear ring is being replaced, do not use lubricants on the metal-to-metal fit when pressing in the replacement.
8. If the impeller is removed, as for example to effect a mechanical seal change, this procedure must be followed: Old impeller bolt and impeller O-ring cannot be reused.
9. Install the mechanical seal stationary seat in the seal housing, using soapy water as a lubricant to ease insertion.
10. **S-Group** – Install the mechanical seal spring retainer, spring and rotary assembly on the shaft sleeve using soapy water to lubricate. Slide the shaft sleeve over the pump shaft, be sure that a new shaft sleeve O-ring is used.
NOTE: THE SHAFT SLEEVE O-RING AND IMPELLER WASHER O-RING ARE ALMOST IDENTICAL IN DIAMETER. BE SURE TO USE THE SQUARE CROSS-SECTION O-RING IN THE IMPELLER WASHER. THE ROUND CROSS-SECTION O-RING IS USED IN THE SHAFT SLEEVE.
11. **M-Group** – Install the mechanical seal spring and rotary on the shaft sleeve using soapy water to lubricate. Slide the shaft sleeve over the pump shaft. Be sure that a new shaft sleeve o-ring is used. Place the mechanical seal spring retainer over the impeller hub.
12. Place the impeller key into the shaft keyway and slide the impeller in place. Install the impeller stud and impeller washer. Be sure that a new impeller o-ring is used. Tighten S-Group (3/8" thread) to 17 lb.ft. and M-Group (1/2" thread) to 38 lb.ft.
13. Replace casing bolts and tighten in a crossing sequence to the torque values indicated below.
S-Group – 25 lb.-ft. (35 N-m)
M-Group – 37 lb.-ft. (50 N-m)
14. Check reassembled unit for binding by rotating shaft with appropriate tool from motor end.
15. If rubbing exists, loosen casing bolts and proceed with tightening sequence again.

7 Troubleshooting

7.1 Operation troubleshooting

Error	Cause
Motor does not start and no noise or vibration occurs	Power supply not connected
	Fuses or protection device are tripped or defective
	Loose or broken electrical connections
Motor won't start but generates noise and vibrates	Motor not wired as directed on diagram
	Shaft locked due to mechanical obstructions in motor or pump
	Low voltage or phase loss on three-phase supply
Pump does not deliver rated capacity	Pump is not filled and primed
	Pump has lost prime due to leaks in suction line
	Direction of rotation incorrect. See Rotation.
	Head required is higher than that originally specified. Valve may be partially closed.
	Foot valve clogged
	Suction lift too high
	Suction pipe diameter too small
Protection trips as unit starts	Phase loss on three-phase supply
	Protection device may be defective
	Loose or broken electrical connections
	Check motor resistance and insulation to ground
Protection device trips too often	Protection may be set to a value lower than motor full load
	Phase loss due to faulty contacts or supply cable
	Liquid is viscous or its specific gravity is too high
	Rubbing occurs between rotating and stationary parts
Shaft spins with difficulty	Check for obstructions in the motor or the pump
	Rubbing occurs between rotating and stationary parts
	Check bearings for correct conditions
Pump vibrates, runs noisily, and flow rate is uneven	Pump runs beyond rated capacity
	Pump or piping not correctly secured
	Suction lift too high
	Suction pipe diameter too small
	Cavitation caused by insufficient liquid supply or excessive suction losses
	Impeller blockage
When stopped, unit turns slowly in the reverse direction	Leaks on air locks in suction pipe
	Partial blockage in check valve
In pressure boosting applications, the unit start and stops too often	Pressure switch settings are incorrect
	Tank size may be incorrect

Error	Cause
In pressure boosting applications, the unit does not stop	Pressure switch maximum setting is higher than was specified
	Direction of rotation incorrect. See Rotation

8 Product Warranty

Commercial warranty

Warranty. For goods sold to commercial buyers, Seller warrants the goods sold to Buyer hereunder (with the exception of membranes, seals, gaskets, elastomer materials, coatings and other "wear parts" or consumables all of which are not warranted except as otherwise provided in the quotation or sales form) will be (i) be built in accordance with the specifications referred to in the quotation or sales form, if such specifications are expressly made a part of this Agreement, and (ii) free from defects in material and workmanship for a period of twelve (12) months from the date of installation or eighteen (18) months from the date of shipment (which date of shipment shall not be greater than thirty (30) days after receipt of notice that the goods are ready to ship), whichever shall occur first, unless a longer period is specified in the product documentation (the "Warranty").

Except as otherwise required by law, Seller shall, at its option and at no cost to Buyer, either repair or replace any product which fails to conform with the Warranty provided Buyer gives written notice to Seller of any defects in material or workmanship within ten (10) days of the date when any defects or non-conformance are first manifest. Under either repair or replacement option, Seller shall not be obligated to remove or pay for the removal of the defective product or install or pay for the installation of the replaced or repaired product and Buyer shall be responsible for all other costs, including, but not limited to, service costs, shipping fees and expenses. Seller shall have sole discretion as to the method or means of repair or replacement. Buyer's failure to comply with Seller's repair or replacement directions shall terminate Seller's obligations under this Warranty and render the Warranty void. Any parts repaired or replaced under the Warranty are warranted only for the balance of the warranty period on the parts that were repaired or replaced. Seller shall have no warranty obligations to Buyer with respect to any product or parts of a product that have been: (a) repaired by third parties other than Seller or without Seller's written approval; (b) subject to misuse, misapplication, neglect, alteration, accident, or physical damage; (c) used in a manner contrary to Seller's instructions for installation, operation and maintenance; (d) damaged from ordinary wear and tear, corrosion, or chemical attack; (e) damaged due to abnormal conditions, vibration, failure to properly prime, or operation without flow; (f) damaged due to a defective power supply or improper electrical protection; or (g) damaged resulting from the use of accessory equipment not sold or approved by Seller. In any case of products not manufactured by Seller, there is no warranty from Seller; however, Seller will extend to Buyer any warranty received from Seller's supplier of such products.

THE FOREGOING WARRANTY IS EXCLUSIVE AND IN LIEU OF ANY AND ALL OTHER EXPRESS OR IMPLIED WARRANTIES, GUARANTEES, CONDITIONS OR TERMS OF WHATEVER NATURE RELATING TO THE GOODS PROVIDED HEREUNDER, INCLUDING WITHOUT LIMITATION ANY IMPLIED WARRANTIES OF MERCHANTABILITY AND FITNESS FOR A PARTICULAR PURPOSE, WHICH ARE HEREBY EXPRESSLY DISCLAIMED AND EXCLUDED. EXCEPT AS OTHERWISE REQUIRED BY LAW, BUYER'S EXCLUSIVE REMEDY AND SELLER'S AGGREGATE LIABILITY FOR BREACH OF ANY OF THE FOREGOING WARRANTIES ARE LIMITED TO REPAIRING OR REPLACING THE PRODUCT AND SHALL IN ALL CASES BE LIMITED TO THE AMOUNT PAID BY THE BUYER FOR THE DEFECTIVE PRODUCT. IN NO EVENT SHALL SELLER BE LIABLE FOR ANY OTHER FORM OF DAMAGES, WHETHER DIRECT, INDIRECT, LIQUIDATED, INCIDENTAL, CONSEQUENTIAL, PUNITIVE, EXEMPLARY OR SPECIAL DAMAGES, INCLUDING BUT NOT LIMITED TO LOSS OF PROFIT, LOSS OF ANTICIPATED SAVINGS OR REVENUE, LOSS OF INCOME, LOSS OF BUSINESS, LOSS OF PRODUCTION, LOSS OF OPPORTUNITY OR LOSS OF REPUTATION.

Xylem |'zīləm|

- 1) The tissue in plants that brings water upward from the roots;
- 2) a leading global water technology company.

We're a global team unified in a common purpose: creating advanced technology solutions to the world's water challenges. Developing new technologies that will improve the way water is used, conserved, and re-used in the future is central to our work. Our products and services move, treat, analyze, monitor and return water to the environment, in public utility, industrial, residential and commercial building services settings. Xylem also provides a leading portfolio of smart metering, network technologies and advanced analytics solutions for water, electric and gas utilities. In more than 150 countries, we have strong, long-standing relationships with customers who know us for our powerful combination of leading product brands and applications expertise with a strong focus on developing comprehensive, sustainable solutions.

For more information on how Xylem can help you, go to www.xylem.com



Xylem Inc.
1 Goulds Drive
Auburn - NY 13021
USA
Tel: +1 (866) 325-4210
Fax: +1 (800) 322-5877
www.xylem.com/goulds

Visit our Web site for the latest version of this document and more information

The original instruction is in English. All non-English instructions are translations of the original instruction.

© 2022 Xylem Inc

Goulds is a registered trademark of Goulds Pumps, Inc. and is used under license.