

Parts Manual
D03-991-2406

Hydra-Cell[®] **INDUSTRIAL PUMPS**

Models: D-03, G-03, G-13, M-03 and M-23
Mono-Block Kel-Cell Versions

IMPORTANT

Record your pump model number and serial number here for easy reference:

Model No. _____

Serial No. _____

Date of Purchase _____

When ordering parts or making inquiries about this pump, please mention the model and serial numbers.

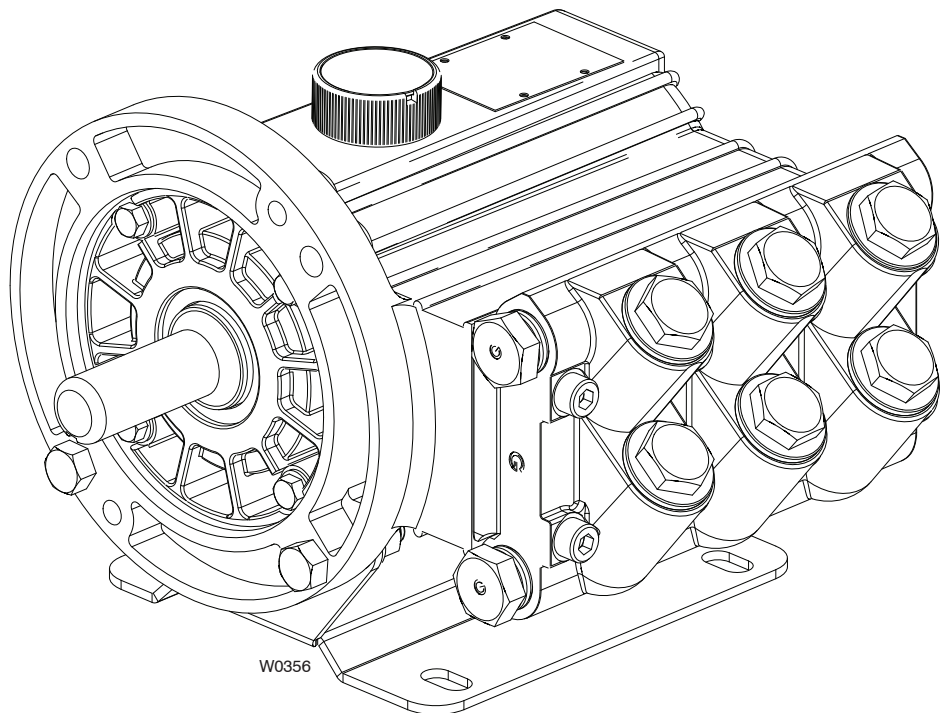

WANNER ENGINEERING, INC.

1204 Chestnut Avenue, Minneapolis, MN 55403
TEL: (612) 332-5681 FAX: (612) 332-6937
TOLL-FREE FAX [US only]: (800) 332-6812

www.hydra-cell.com
email: sales@wannereng.com

D/G-03 Mono-Block Fluid End Parts

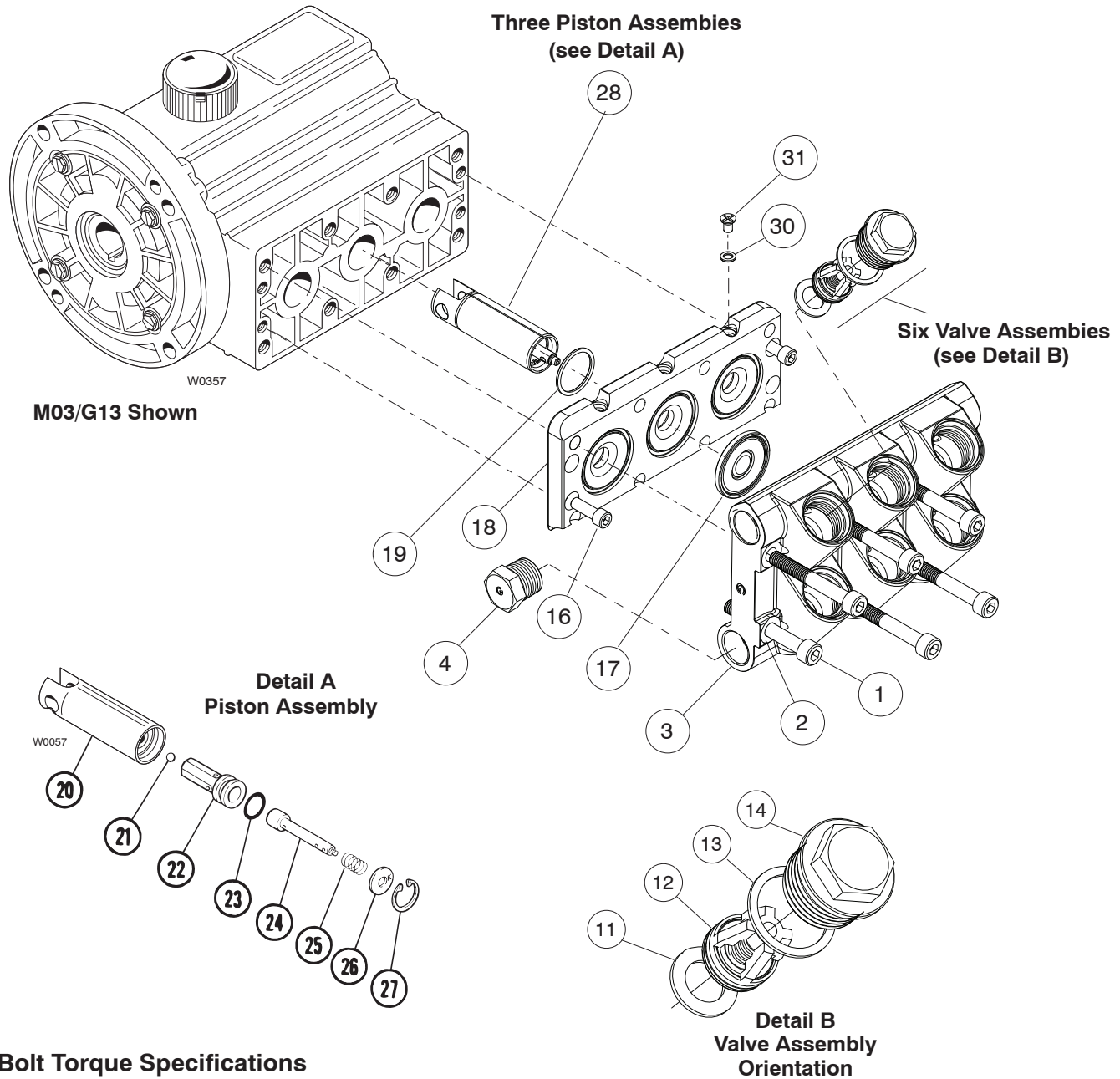

Bolt Torque Specifications

Ref. No.	Assembly Torque
1	15 ft-lbs/20 Nm
4	Hand tight

D/G-03 Mono-Block Fluid End Parts

Ref. No.	Part Number	Description	Quantity/ Pump
1	163-032	Bolt, Hex-hd, 2.25 in.	8
	163-031	Screw, Cap, soc-hd, 60 mm (metallic head only)	8
2	C22-014-2000	Washer, 5/16" (metallic head only)	8
3	163-021-01	Manifold, Brass, NPT	1
	163-037-01	Manifold, 316 SST, NPT	1
	163-021-02	Manifold, Brass, BSPT	1
	163-037-02	Manifold, 316 SST, BSPT	1
4	163-036-01	Plug, Brass, 1/2 in. NPT	2
	163-036-02	Plug, Brass, 1/2 in. BSPT	2
	163-036-03	Plug, 316 SST, 1/2 in. NPT	2
	163-036-04	Plug, 316 SST, 1/2 in. BSPT	2
11	D03-125-2317	Washer, Dampening, polypropylene...	6
	D03-125-2318	Washer, Dampening, Kynar	6
12*	163-033-XX	Valve Assembly..... 6 (Select from list)	
	163-033-01	. Polypropylene, 316 SST, Buna	
	163-033-02	. Polypropylene, 316 SST, Viton	
	163-033-03	. Polypropylene, 316 SST, EPDM	
	163-033-04	. Polypropylene, 316 SST, Neoprene	
	163-033-05	. Polypropylene, 17-4 SST, Buna	
	163-033-06	. Polypropylene, 17-4 SST, Viton	
	163-033-07	. Polypropylene, 17-4 SST, EPDM	
	163-033-08	. Polypropylene, 17-4 SST, Neoprene	
	163-033-09	. Polypropylene, Hastelloy C, Buna	
	163-033-10	. Polypropylene, Hastelloy C, Viton	
	163-033-11	. Polypropylene, Hastelloy C, EPDM	
	163-033-12	. Polypropylene, Hastelloy C, Neoprene	
	163-033-13	. Kynar, 316 SST, Buna	
	163-033-14	. Kynar, 316 SST, Viton	
	163-033-15	. Kynar, 316 SST, EPDM	
	163-033-16	. Kynar, 316 SST, Neoprene	
	163-033-17	. Kynar, 17-4 SST, Buna	
	163-033-18	. Kynar, 17-4 SST, Viton	
	163-033-19	. Kynar, 17-4 SST, EPDM	
	163-033-20	. Kynar, 17-4 SST, Neoprene	
	163-033-21	. Kynar, Hastelloy C, Buna	
	163-033-22	. Kynar, Hastelloy C, Viton	
	163-033-23	. Kynar, Hastelloy C, EPDM	
	163-033-24	. Kynar, Hastelloy C, Neoprene	

Ref. No.	Part Number	Description	Quantity/ Pump
13	163-028-01	O-ring, Buna	6
	163-028-02	O-ring, Viton	6
	163-028-04	O-ring, EPDM	6
	163-028-03	O-ring, Neoprene	6
14	163-023-01	Plug, Valve, brass	6
	163-023-02	Plug, Valve, 316 SST	6
16	D03-088-2010	Screw, Cap, soc-hd, 3/4 in.	2
	G03-088-2010	Screw, Cap, soc-hd, 20 mm	2
17	K03-018-1240	Diaphragm, Kel-Cell, Buna-N-XS	3
	K03-018-1245	Diaphragm, Kel-Cell, Viton-XT	3
	K03-018-1243	Diaphragm, Kel-Cell, EPDM	3
	K03-018-1242	Diaphragm, Kel-Cell, Neoprene	3
18	163-035	Diaphragm Plate, Kel-Cell, mb	1
19	D03-075-2110	O-ring, Diaphragm plate, Buna	3
20	K03-014-1004	Piston, Kel-Cell	3
21	D10-015-3010	Ball	3
22	K03-043-1010	Valve Cylinder, Kel-Cell	3
23	C23-009-2110	O-ring, Valve cylinder, Buna, Kel-Cell	3
24	K03-044-1010	Valve Plunger, Kel-Cell	3
25	K03-045-3110	Spring, Sleeve valve, Kel-Cell	3
26	K03-049-1000	Washer, Kel-Cell	3
27	D03-048-2210	Snap Ring	3
28	K03-014-1210	Piston Assembly, Kel-Cell	3
30	102-210	O-ring, Viton	3
31	D10-030-2010	Screw, Flat-hd, SST	3
73	D03-087-2011	Screw, Hex-hd (D-03 only)	2

?
?

*Special Tools

Valve Removal Tool: D03-086-2010 1/4-20 X 1.5 inches long ST Screw

D/G-03 Mono-Block Hydraulic End Parts

G-13 Pump Housing

M-23 Pump Housing

M-23 Only

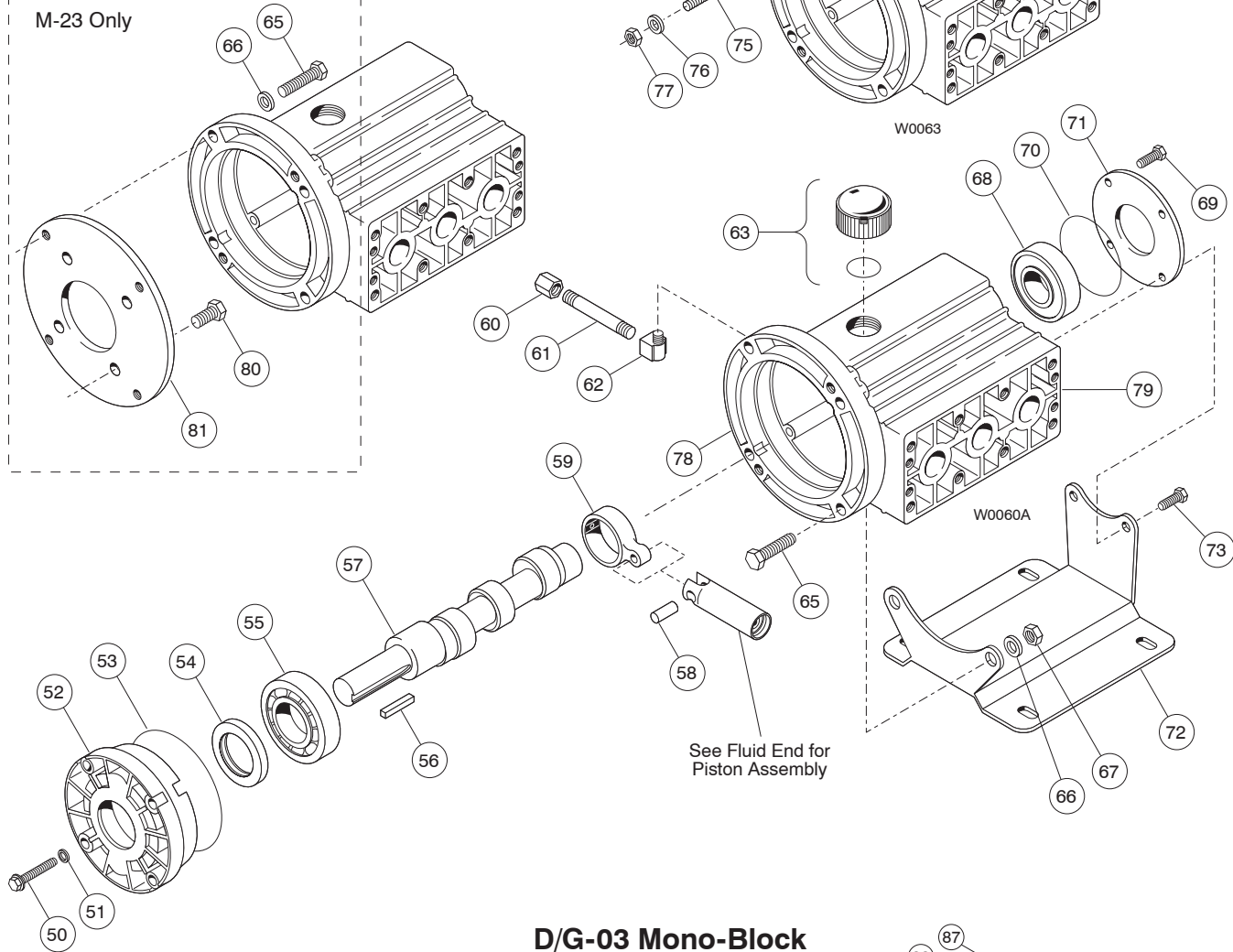

D/G-03 Mono-Block Pump/Motor Adapter

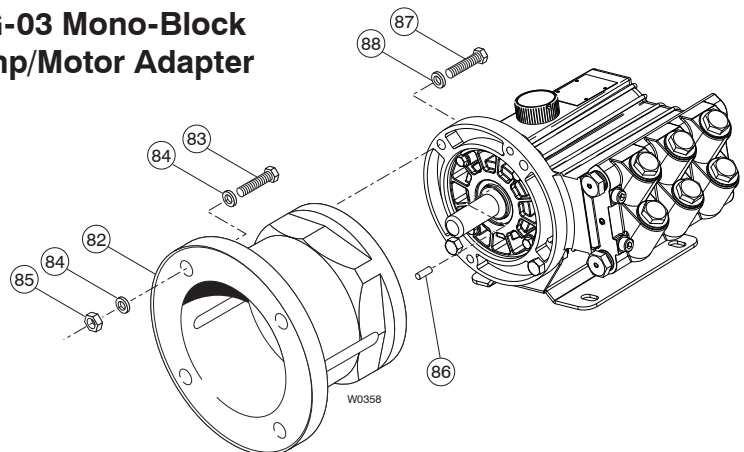

D/G-03 Mono-Block Hydraulic End Parts

Ref. No.	Part Number	Description	Quantity/ Pump
50	D03-086-2010	Screw, Cap, hex-hd, with washer	4
	G03-086-2010	Screw, Cap, hex-hd, with washer	4
51	D25-047-2110	O-ring, back cover screws, Buna	4
52	D03-131-1000	Back Cover	1
53	D03-037-2110	O-ring, Back cover, Buna	1
54	D03-031-2110	Seal, Buna	1
55	D03-011-2910	Back Bearing	1
56	D10-085-2210	Key, Shaft	1
57	D03-009-1002	(E) Crank Shaft, shaft-driven, 7/8" O.D., 2.2 GPM @ 1750 RPM	1
	D03-009-1003	(X) Crank Shaft, shaft-driven, 7/8" O.D., 3.0 GPM @ 1750 RPM	1
	M03-009-1002	(E) Hollow Shaft, 56C direct drive, 5/8" I.D. (close-coupled), 2.2 GPM @1750 RPM	1
	M03-009-1003	(X) Hollow Shaft, 56C direct drive, 5/8" I.D. (close-coupled), 3.0 GPM @1750 RPM	1
	M13-009-1003	(X) Hollow Shaft, IEC 90 direct drive, 24 mm I.D. (closed-coupled), 9.9 l/min @1450 RPM	1
	M23-009-1004	(X) Hollow Shaft, 20 mm I.D. (for Honda Engine), 3.0 GPM @ 1750 RPM	1
58	D03-133-1000	Pin	3
59	D03-132-1000	Connecting Rod	3
60	D10-078-2210	Cap, Brass, 1/8 in.	1
61	D10-077-2210	Pipe, Brass, 1/8 in.	1
62	D10-076-2210	Elbow, Brass, 1/8 in.	1

Ref. No.	Part Number	Description	Quantity/ Pump
63	D03-039-1030	Cap with O-ring, oil fill	1
65	D03-068-2010	Screw, Cap, soc-hd, 1-1/2 in.	4*
	G03-068-2010	Screw, Cap, soc-hd, 40 mm (G-03 only)	2
66	D10-048-2010	Washer, 38 in. [*]	4
	G25-048-2010	Washer, M10 (G-03 only)	2
67	D10-028-2010	Nut, hex, 3/8 in. (D-03 only)	2
	G10-028-2010	Nut, hex, M10 (G-03 only)	2
68	D03-010-2910	Front Bearing	1
69	D03-087-2010	Screw, Cap, hex-hd, 1/2 in.	4*
70	D40-074-2110	O-ring, Front cover, Buna	1
71	D03-130-1000	Front Cover	1
72	D03-025-1010	Base Plate (D-03/G-03 only)	1
73	D03-089-2011	Screw, Cap, hex-hd, 3/4 in. (D-03 only)	2
75	M13-151-1000	Offset Bolt (G-13 only)	4
76	G25-048-2010	Washer, Lock, 10 mm (G-13 only)	8
77	G10-028-2010	Nut, Hex, 10 mm (G-13 only)	8
78	D03-001-1001	Pump Housing	1
	G13-001-1001	Pump Housing	1
79	D10-040-2410	Nameplate	1
80	M23-085-2010	Screw, Cap, hex-hd, 16 mm	4
81	M23-025-1010	Plate, Adapter	1

* Quantity 2 on Model D-03.

D/G-03 Mono-Block Pump/Motor Adapter Kits

D-03 Pump/Motor Adapter Kits

56C-145TC NEMA C-Face Motors (Kit No. A04-001-1202)

182-215TC NEMA C-Face Motors (Kit No. A04-002-1202)

G-03 Pump/Motor Adapter Kits

IEC 80-90 B5 Flange Motors (Part No. A04-003-1202)

IEC 100-112 B5 Flange Motors (Part No. A04-004-1202)

Ref No.	Description	For D-03	For D-03	For G-03	For G-03	Qty/Kit
		A04-001-1202	A04-002-1202	A04-003-1202	A04-004-1202	
		Part Number	Part Number	Part Number	Part Number	
82	Pump/Motor Adapter	A04-032-1000	A04-033-1002	A04-032-1001	A04-033-1003	1
83	Screw, Cap, socket-head	D10-087-2010	M10-110-2000	G03-068-2010	A04-043-2010	4
84	Lockwasher	D10-048-2010	M10-111-2000	A04-044-2010	M10-111-2000	8
85	Nut	N/A	N/A	A04-047-2010	A04-045-2010	4
86	Pin	D03-026-2211	D03-026-2211	D03-026-2211	D03-026-2211	2
87	Screw, Cap, socket-head	G03-068-2010	G03-068-2010	G03-068-2010	G03-068-2010	4
88	Lockwasher	G25-048-2010	G25-048-2010	G25-048-2010	G25-048-2010	4

D/G-03 Mono-Block Replacement Parts Kits

TO ORDER REPLACEMENT PARTS KIT: A Replacement Parts Kit contains 11 digits corresponding to customer-specified design options.

1	2	3	4	5	6	7	8	9	10	11
---	---	---	---	---	---	---	---	---	----	----

Digit	Order Code	Description
1-3	D03	Pump Configuration For all D-03, G-03, M-03, G13, and M-23 pumps with 5th digit "M" in pump model number
4		Kit Designator
	K	Complete Fluid End Kit
	D	Diaphragm Kit
	V	Valve Kit (diaphragm not included)
5-6	61	Pump Head Version All Mono-Block Versions
7		Diaphragm & O-ring Material
	E	EPDM
	G	Viton®-XT
	P	Neoprene
	T	Buna-N-XS
8		Valve Seat Material
	H	17-4 PH Stainless Steel
	S	316 Stainless Steel
	T	Hastelloy® C
	X	Not included in Diaphragm Kit
9		Valve Material
	F	17-4 PH Stainless Steel – Machined
	H	17-7 PH Stainless Steel
	G	Nitronic 50
	S	316 Stainless Steel
	B	Hastelloy® C
	X	Not included in Diaphragm Kit
10		Valve Springs
	E	Elgiloy®
	S	316 Stainless Steel
	T	Hastelloy® C
	X	Not included in Diaphragm Kit
11		Valve Spring Retainers
	M	Kynar®
	P	Polypropylene

Kit Contents

Part Number*	Description	Qty	Kit Designator		
			K	D	V
K03-018- ___	Diaphragm	3	•	•	
163-033- ___	Valve Assembly	6	•		•
163-028- ___	O-Ring, Valve plug	6	•		•
D03-125- ___	Washer, dampening	6	•		•
A01-113-3400	Threadlocker	1	•	•	

* Last digits of part numbers with ___ refer to specific material of construction.

Limited Warranty

Wanner Engineering, Inc. extends to the original purchaser of equipment manufactured by it and bearing its name, a limited one-year warranty from the date of purchase against defects in material or workmanship, provided that the equipment is installed and operated in accordance with the recommendations and instructions of Wanner Engineering, Inc. Wanner Engineering, Inc. will repair or replace, at its option, defective parts without charge if such parts are returned with transportation charges prepaid to Wanner Engineering, Inc., 1204 Chestnut Avenue, Minneapolis, Minnesota 55403.

This warranty does not cover:

1. The electric motors (if any), which are covered by the separate warranties of the manufacturers of these components.
2. Normal wear and/or damage caused by or related to abrasion, corrosion, abuse, negligence, accident, faulty installation or tampering in a manner which impairs normal operation.
3. Transportation costs.

This limited warranty is exclusive, and is in lieu of any other warranties (express or implied) including warranty of merchantability or warranty of fitness for a particular purpose and of any non contractual liabilities including product liabilities based on negligence or strict liability. Every form of liability for direct, special, incidental or consequential damages or loss is expressly excluded and denied.



WANNER ENGINEERING, INC.

1204 Chestnut Avenue, Minneapolis, MN 55403
TEL: (612) 332-5681 FAX: (612) 332-6937
TOLL-FREE FAX [US only]: (800) 332-6812

www.hydra-cell.com
email: sales@wannereng.com