

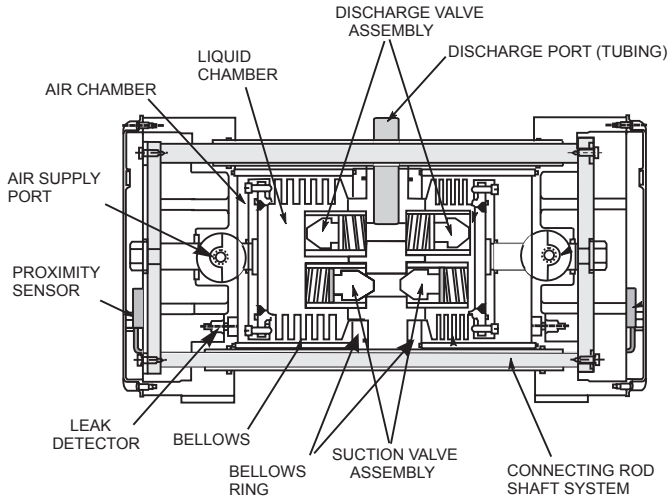

IWAKI WALCHEM Corporation

FW-20HT



- PTFE/PFA Liquid End Construction
- Pressure capabilities to 75 PSI
- Flow rates to 25 L/min
- Wide temperature capabilities (10-180°C)
- Leak detection and drive sensing

Dimensions

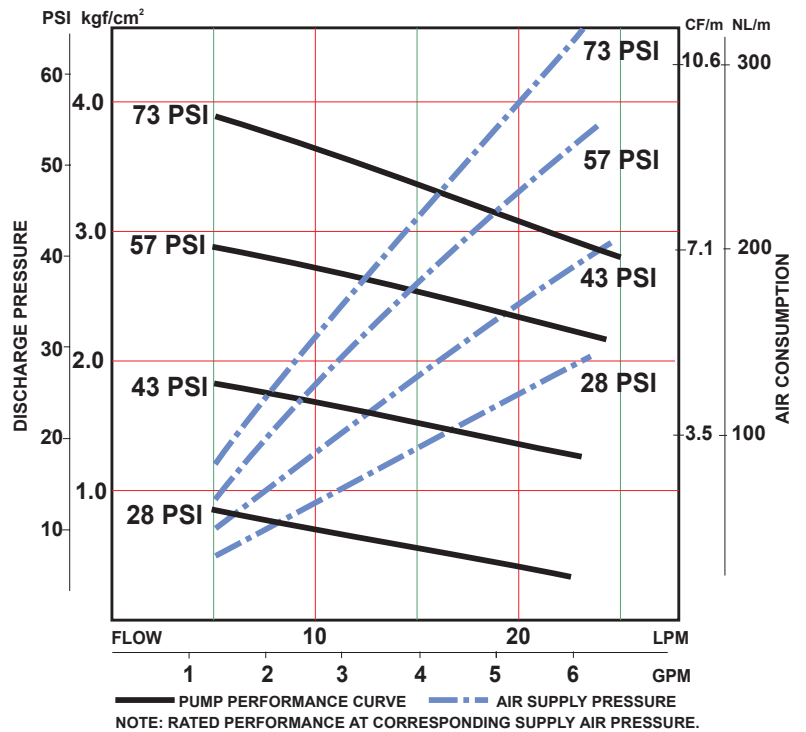
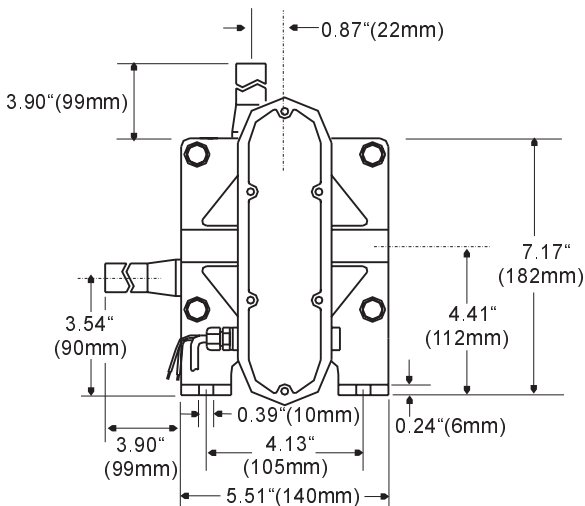
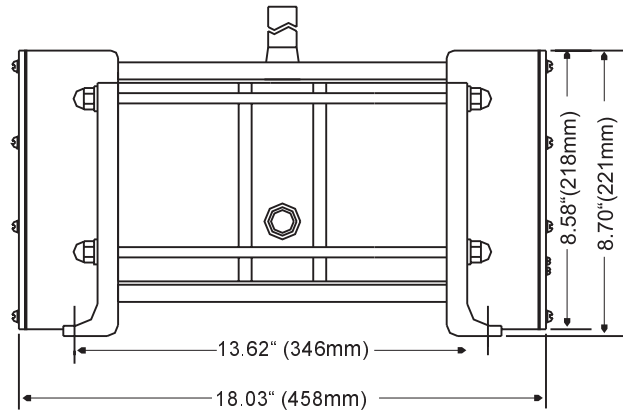

Specifications

FW-20HT				
Max flow rate	GPM (LPM)	6.5 (25)		
Liquid Temperature	°F (°C)	50-212 (10-100)	213-302 (101-150)	303-356 (151-180)
Supply air pressure	PSI	28-73	21-43	21-28
Ambient temperature	°F (°C)	32-104 (0-40)		
Max stroke speed	SPM	120		
Pump connection size		3/4" PFA tube		
Supply air connection size		1/4" PT (2)		
Material	Wetted parts	PTFE, PFA		
	Non-wetted parts	PTFE COATED ALUMINUM, SS304		

P/N IF20351.B