



***IWAKI WALCHEM***  
***AIR DRIVEN BELLOWS PUMP***  
***FW SERIES***  
***INSTRUCTION MANUAL***

## INTRODUCTION

Thank you for selecting an Iwaki Walchem FW Series Air Driven Bellows Pump. These pumps are designed exclusively for pumping semiconductor grade, high purity liquids. To ensure safety and maximum service life of the pump, please read this instruction manual thoroughly prior to installation and operation.



### CAUTION!

1. This instruction manual details the proper installation, operation and safety measures necessary to ensure the safe and efficient use of this pump. Failure to adhere to the described handling, installation and operating procedures may lead to malfunction or damage to the pump.
2. Always employ full safety measures and precautions when installing or servicing this type of pump based on the liquid being handled. Common applications are hazardous strong acids. Follow all safety procedures recommended by the chemical manufacturer.
3. To operate the pump, a controller system with adequate control and safety features is necessary. The pump always requires the use of a 4-way solenoid valve. Please read the respective instruction manuals carefully for the proper installation and operating guidelines.
4. Please ensure that the end-user receives a copy of this instruction manual for reference.

## CONTENTS

SECTION	PAGE
1 UNPACKING AND INSPECTION .....	2
2 OPERATING PRINCIPLE .....	2
3 IDENTIFICATION CODES .....	4
4 SPECIFICATIONS.....	4
5 HANDLING PRECAUTIONS .....	8
6 INSTALLATION, PIPING AND WIRING.....	11
8 TROUBLESHOOTING GUIDE .....	21
9 MAINTENANCE AND INSPECTION.....	23

# 1 Unpacking and Inspection

---

Open the package and check that the product conforms to your order. Also check each of the following points. For any problem or inconsistency, contact Iwaki Walchem Corporation at once.

1. Check that the model number indicated on the nameplate conforms to the specifications of your order.
2. Check that the pump has not been accidentally damaged or that any fasteners have not been loosened in transit.

# 2 Operating Principle

---

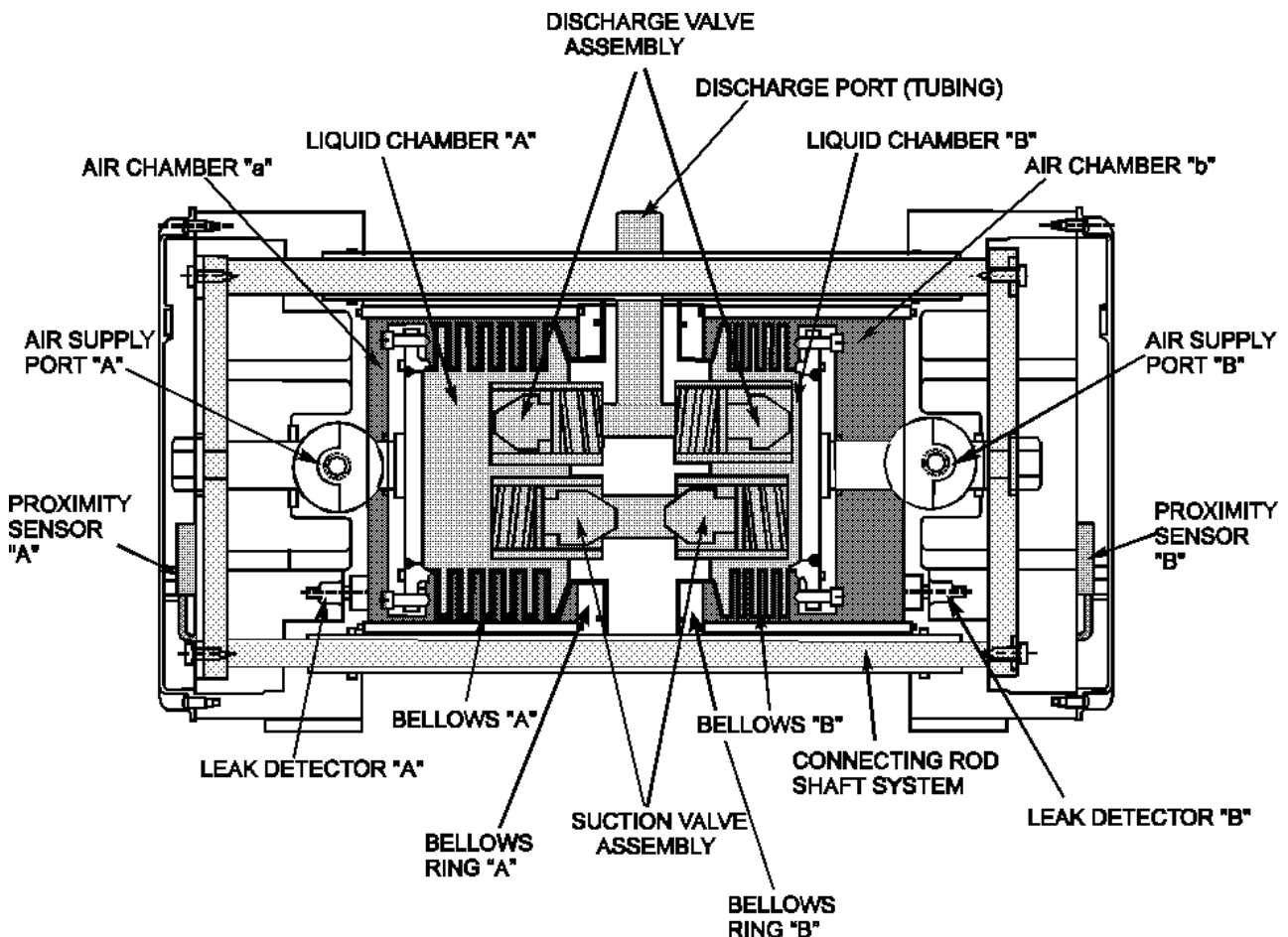

Iwaki Walchem FW Series Air Driven Bellows Pumps consist of a high purity virgin fluoroplastic pump head assembly with dual bellows and internal valving. A bellows is affixed on each side of the pump head assembly which houses the suction and discharge valves. A connecting rod and shaft system are mounted to the bellows and structural air chambers which seal against the pump head assembly. The bellows move reciprocally in the air chambers as a result of alternating pressurization of the air chambers, by which liquid is pumped continuously. Position of each bellows is monitored by proximity sensors mounted on cylinder head covers. Signals from the proximity are used by the controller system to govern the 4-way solenoid valve and subsequent pressurization of the pump air chambers.

Operating Sequence:

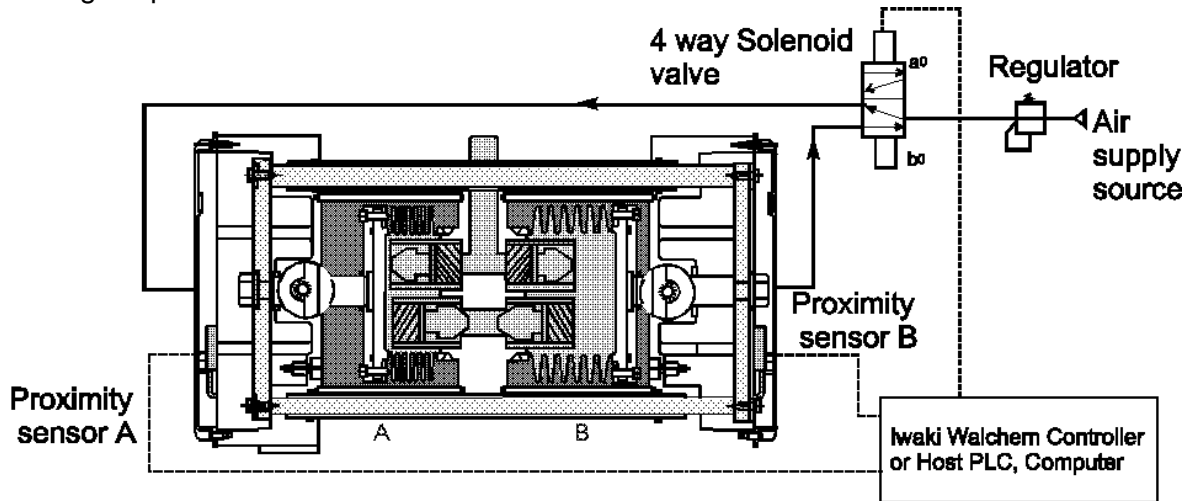

Refer to Figure 2. When pressurized air is supplied to chamber 'a' of the pump, bellows 'A' is compressed and fluid is discharged from the bellows through the pump head discharge (outlet) port. Simultaneously, bellows 'B' is extended and fluid is drawn into the bellows through the pump head suction (inlet) port. Air is being exhausted from the pump chamber 'b' during this process. When the 'B' bellows is fully extended, proximity sensor 'B' is activated to signal the completion of this stroke to the controller system.

The controller system receives the input signal from proximity sensor 'B' and changes the output signal to the 4-way solenoid valve to switch it from the  $a_0$  position to  $b_0$  position.

Refer to Figure 3. Once the 4-way solenoid valve is in the  $b_0$  position, pressurized air is supplied to chamber 'b' of the pump and the process outlined above is reversed. Fluid is discharged from bellows 'B' while bellows 'A' is in its suction stroke and air is exhausted from chamber 'a.' Upon completion of this pump stroke, proximity sensor 'A' is activated and the controller signals the valve to switch from the  $b_0$  position to  $a_0$ .

With a constant air supply, this sequence is repeated continuously and the pump achieves a constant flowrate based on installation and operating conditions.

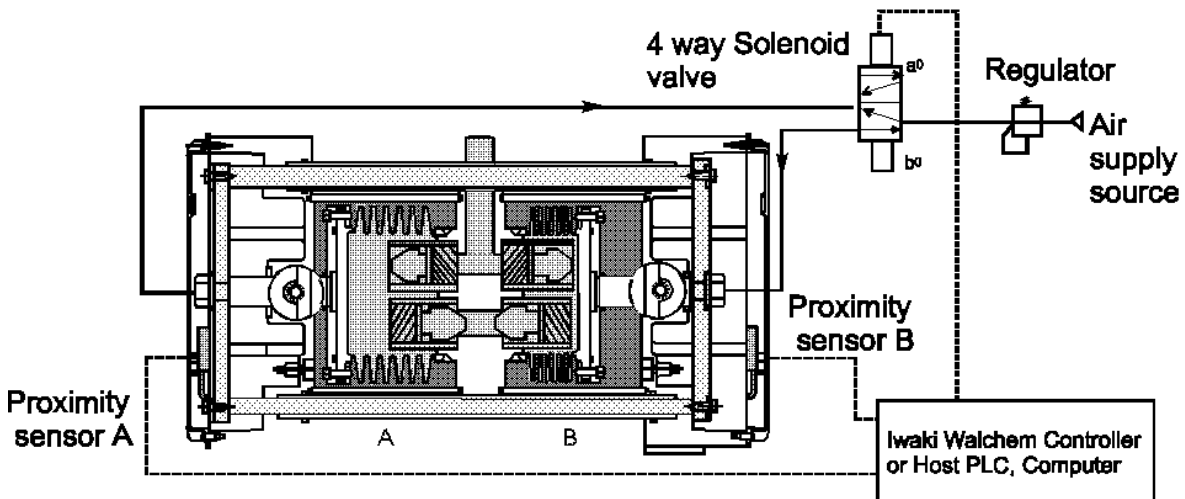

### 3 Identification Codes

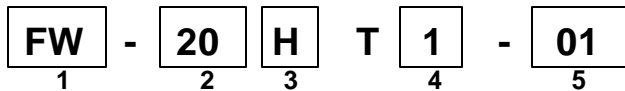

1. Series code: FW: Pump for high pressure applications
2. Maximum discharge volume: 20: 6.3 GAL/min (24L/min)  
40: 11.4 GAL/min (43L/min)  
80: 22.7 GAL/min (86L/min)
3. Temperature Capabilites: H: High Temperature      No Symbol: Low Temperature
4. Bellows Attachment  
T1: Mechanical clamp type, rebuildable (standard)  
T2: Welded Type
5. Special modifications

### 4 Specifications

#### ■ FF-(H)T Pump Specifications

MODEL		FW-20T	FW-40T	FW-80T
Max. Flow Rate	GPM(Lpm)	6.3 (24)	11.4 (43)	22.7 (86)
Liquid Temperature	°F(°C)	50 - 212 (10 - 100)		
Supply Air Pressure*	PSI	29 - 73		
Ambient Temperature	°F(°C)	32 -104 (0 - 40)		
Maximum Stroke Speed	SPM	120	80	80
Pump Connection Size		¾" PFA TUBE	1" PFA TUBE	1" PFA TUBE
Supply Air Connection Size		¼" PT (2)	3/8" PT (2)	½" PT (2)
Material	Wetted Parts	PTFE, PFA		
	Non-Wetted Parts	PTFE coated Aluminum, SS304		

MODEL		FW-20HT			FW-40HT			FW-80HT
Max. Flow Rate	GPM(Lpm)	6.3 (24)			11.4 (43)			22.7 (86)
Liquid Temperature	°F(°C)	50-212 (10-100)	212-300 (101-150)	300-356 (151-180)	50-212 (10-100)	212-300 (101-150)	300-356 (151-180)	50-212 (10-100)
Supply Air Pressure*	PSI	29 - 73						
Ambient Temperature	°F(°C)	32 -104 (0 - 40)						
Maximum Stroke Speed	SPM	120			80		80	
Pump Connection Size		¾" PFA TUBE			1" PFA TUBE		1" PFA TUBE	
Supply Air Connection Size		¼" PT (2)			3/8" PT (2)		½" PT (2)	
Material	Wetted Parts	PTFE, PFA						
	Non-Wetted Parts	PTFE coated Aluminum, SS304						

\*Maximum supply air pressure is dependent upon fluid temperature.

## ■ Proximity Sensor Specifications (for FW pumps)

Type	High Frequency oscillation switch
Output System	NPN DC open/close output
Power source voltage	+12 VDC/+24 VDC (10-30 VDC), less than 10% p-p ripple allowance rate
Current consumption	Less than 10 mA
Setting distance	Less than 80% of the switching distance
Hysteresis	Less than 20%
Switching distance	4 mm $\pm$ 10%
Switching frequency	400 Hz
Output characteristics	Load current/100 mA max (+12/+24 VDC)
	Residual voltage/Less than 1.5 V (1.0 V typ)
	Leakage current/Less than 100 $\mu$ A
Environmental temperature	-25°C to +70°C
Insulation voltage	1,000 VAC 50/60 Hz 1 min.
Insulation resistance	More than 50 m $\Omega$
Vibration resistance	Double amplitude 1.5 mm, 10-55 Hz
Shock resistance	30G
Protective construction	IP67
Case material	PBT resin
Cable	Oilproof vinyl chloride cable: Length: 1m Diameter: 3.5mm
Connection	<pre> graph LR     Sensor[Sensor] --- Red[Red]     Sensor --- White[White]     Sensor --- Black[Black]     Red --- VDC["+12/+24 VDC"]     White --- Load[Load]     Black --- GND["0 V"]     </pre>

■ **FW Series Pump Dimensions/Weight**

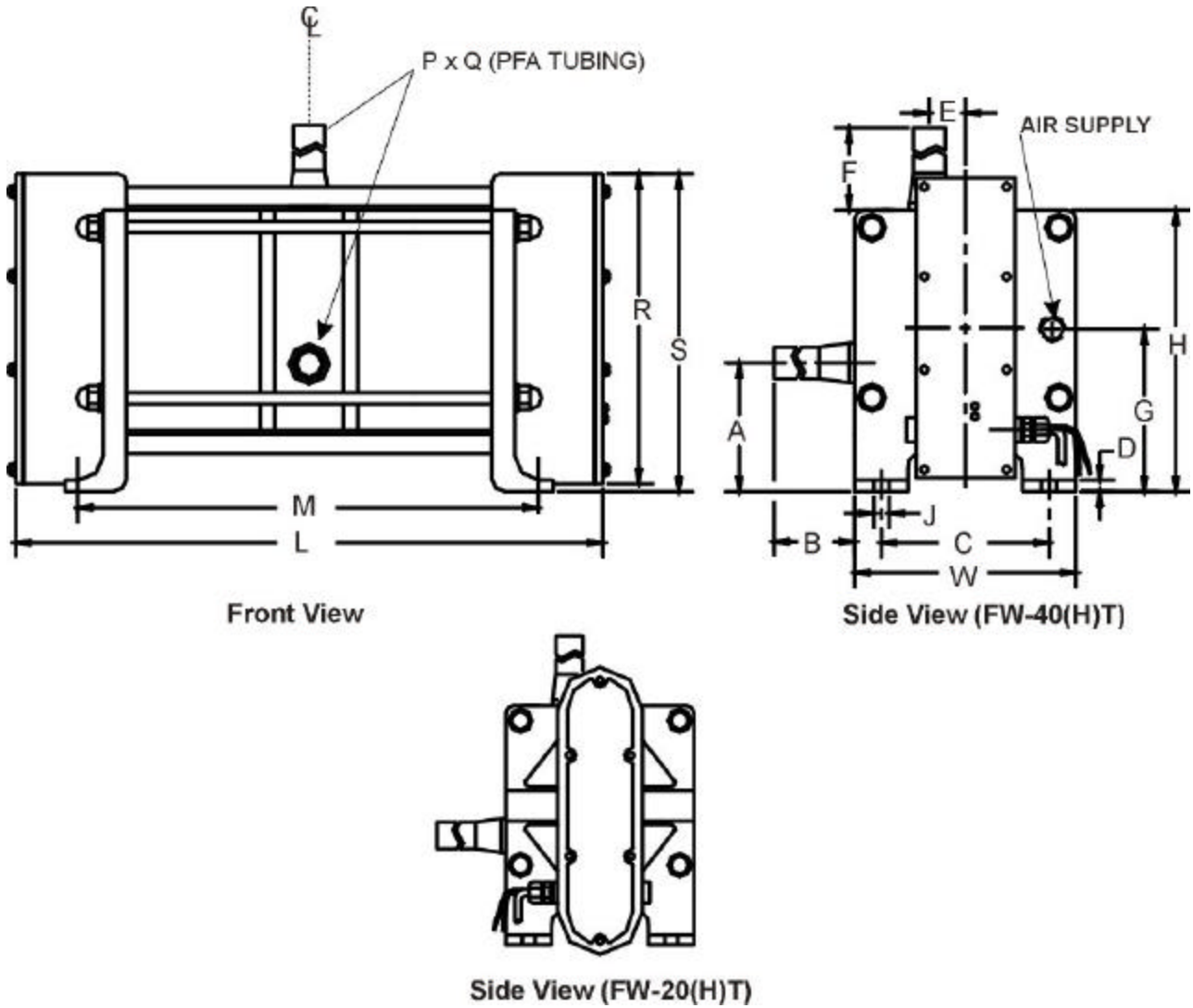

Dimensions in inches

Pump Model	A	B	C	D	E	F	G	H	J	W
FW-20(H)T	3.54	3.90	4.13	0.24	0.87	3.90	4.41	7.17	0.39	5.51
FW-40(H)T	4.02		5.51		1.00		5.12	8.66	0.47	7.09
FW-80T	4.70		7.28		1.06		6.24	12.48	0.51	9.45

Pump Model	L	M	R	S	Weight
FW-20(H)T	18.03	13.62	8.58	8.70	30.8 lbs (14 kg)
FW-40(H)T	21.34	17.09	9.45	9.84	52.8 lbs (24 kg)
FW-80T	23.62	18.22	11.89	12.48	99 lbs (45 kg)

■ **Main Unit and Labels**



**CAUTION!** When cleaning the pump, be careful not to wipe the labels or the pump body with solvent.

Be sure to anchor the base onto the floor.

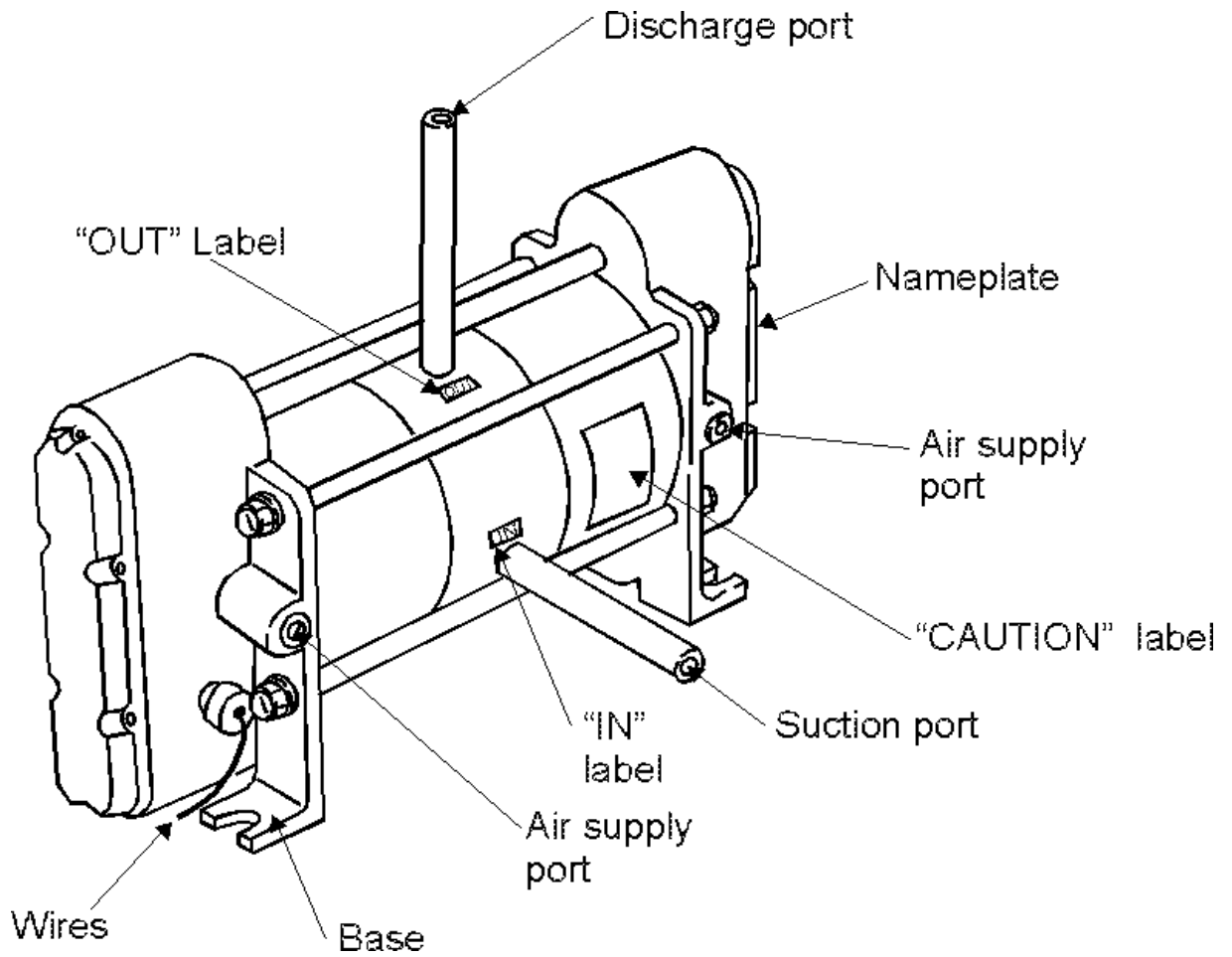



## 5 Handling Precautions

---

The following information deals with measures to ensure safe operation of the pump system. Please read the precautions carefully.

To operate this pump, a 4-way solenoid valve and a controller (Iwaki Walchem supplied model or host PLC) are required. In addition, to enhance system safety, quick exhaust valves are recommended for air exhaust lines.

### ■ General Handling Precautions

- Do not modify the pump:  
Do not alter or modify the pump. Iwaki Walchem Corporation takes no responsibility for accidents or damage that may result from improper modification of the product. Consult Iwaki Walchem to discuss any alteration to the product.
- Do not touch:  
When the pump is handling liquids higher than 122°F (50°C), avoid direct contact with the pump or piping system. Use appropriate hand protection if handling of the pump or piping is necessary.
- Wear protection:  
Always wear protective gear (goggles, face shield, acid resistant gloves, etc.) when maintaining, removing or servicing the pump. In addition, flush the pump completely with DI water prior to any service or maintenance.
- Qualified operators:  
Operation, service, maintenance and removal of the pump should be performed by trained personnel only.
- Disposal of used pump:  
Disposal of used or damaged pumps must be in accordance with all federal and local regulations.
- Return to Iwaki Walchem:  
**All pumps returned to Iwaki Walchem must be decontaminated.** Contact Iwaki Walchem prior to returning any product to discuss proper decontamination and return procedures. Iwaki Walchem will issue a return authorization number to track the return. **Note: Avoid cutting pump suction and discharge tubing.** Leave existing fittings or adequate length of tubing to facilitate testing or evaluation.

## ■ Pump Handling Precautions

- Do not stop pump with discharge line closed:  
When stopping pump operation, first release pressure in the discharge line & then shut off supply air pressure. Residual pressure in the liquid discharge piping may result in deformation of the bellows due to the force of hydraulic pressure.
- Do not suspend operation for extended periods with liquid remaining in pump chamber:  
Suspending pump operation for extended periods may allow permeation of gas into air chambers & piping. This may cause corrosion of pneumatic components. To prevent this problem, purge air from the air chambers to prevent corrosive gas buildup. (e.g., if pump operation is suspended for 2-3 days, run pump for 10 minutes daily to replace air).
- During pump operation:  
Ensure suction or discharge line valves are fully opened during pump operation. *Never close a suction or discharge line valve during operation.*
- Pump at halt:  
Do not pressurize both air chambers simultaneously during operation or while the pump is idle. Some types of double solenoid valves cause pressurization of the two air chambers while the valve is idle. Do not use this type of valve with F Series pumps. Do not pressurize either air chamber when the pump discharge is closed.
- Lifting pump:  
Do not lift the pump by the suction or discharge tubing while installing or removing the pump.
- Pump stroke speed:  
Air bubbles sucked through pump suction piping could cause an air lock condition and the stroke rate to rise to an abnormal level. Safety measures should be taken to avoid running the pump above its maximum stroke speed. See page 12 for details.

FW-20	120 SPM
FW-40,80	80 SPM
- Supply air pressure:  
Any fluctuation in supply air pressure or volume causes a change in pump discharge. Install a regulating valve to stabilize supply air pressure. Never exceed pressure limitations for a specific temperature. (See Spec. Table) Regulate supply air pressure below maximum settings for longer life and protection of the bellows. Maintain a differential pressure (supply air vs. discharge pressure) below 14 PSI (1 kg/cm<sup>2</sup>) to maximize pump service life.
- Liquid temperature range:  
Temperature range of the liquid must be maintained within the specified temperature range for the pump model. (See Specification Table)
- Handle proximity sensor cables with care:  
When wiring or adjusting the sensor, take care not to twist or bend the cable excessively, as this may cause damage to the cable leads or the internal switch connection.

- Unsuitable liquids:  
Pumps should not be used with the following liquids:
  - Liquids that are easily crystallized
  - Liquids containing slurry
  - Solvent based fluids

Service life of the valve and bellows is shortened by liquids that are easily crystallized or contain slurry. Some solvents may cause premature failure due to incompatibility with liquid end materials. Solvent permeation may also be a potential explosion hazard. Consult factory for any solvent or slurry application.

## ■ System Safety Precautions

- Ventilate site:  
When pumping a hazardous liquid, ventilating the cabinet is advised to remove toxic gas which may permeate components and build up inside the equipment.
- Monitor operating condition:  
Use a monitor, etc. to inspect running condition of the system.
- Advance precautions:  
Take advance precautions against pump or system abnormality and perform daily inspections.
- Use clean, dry instrumentation air (CDA) or nitrogen as supply air:  
Supply air mixed with water, oil or dust may affect smooth and normal functioning of the pump. Excessive water in an air chamber may be detected by the leak detection sensor, leading to an alarm condition.
- Use an appropriate filter:  
Select an appropriate filter for the pump, taking into consideration the filtering area, grain-blocking capacity and flow rate characteristics. Venting of the filter is critical. Some filters, depending on structure, may have low air bleeding performance and greatly affect capacity. Be aware of liquid viscosity which may significantly influence flow rate through the filter.
- Do not restrict air exhaust port:  
 **CAUTION!** Do not restrict air exhaust piping of the pump or pneumatic system. Keep exhaust lines as short as possible. The bellows may be deformed as a result of excessive pneumatic back pressure. Quick Exhaust Valves are always recommended.
- Pulse dampeners:  
To reduce vibration in the liquid piping system or reduce pulsation in the liquid flow stream, a full series of pulsation dampeners are available from Iwaki Walchem.

## 6 Installation, Piping and Wiring

### ■ Installation

#### 1. Pump installation position

*In a flooded suction system*, set the pump as close to liquid supply tank as possible. A flooded suction system is recommended for fluid recirculation or transfer applications above room temperature.

*In a suction lift system*, set the suction side piping in accordance with the self-priming capacity and as close to the liquid supply tank as possible.

#### 2. Installation foundation

Select a flat and level rigid foundation (such as a chassis) for installation.

#### 3. Direction of pump

**FW-Series** pumps must be mounted horizontally. Direct the discharge port vertically and the suction port horizontally. Anchor the pump base to the foundation securely with appropriate fasteners.

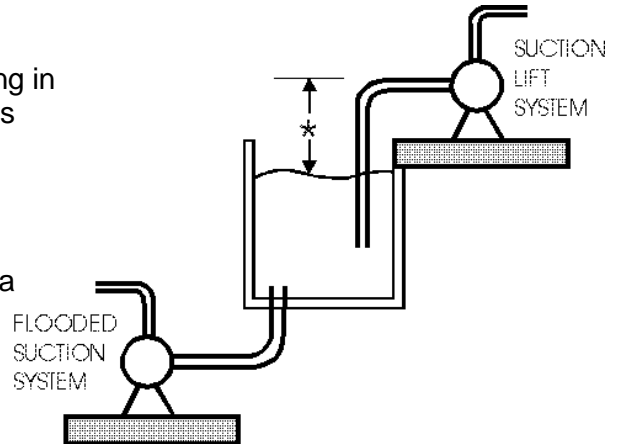

\*Note: The self-priming capacity of F series pumps is based on a pump operating at maximum speed using pure water at room temperature. The suction lift capacity differs with liquid characteristics, temperature, suction piping configuration and pump model. For detailed information, contact Iwaki Walchem Corporation.

### ■ Piping

#### General

1. Sufficiently flush or blow out the tubing and connectors to remove foreign matter from inside surfaces prior to connecting them with the pump.
2. Tube connections should be made so that the extra load of piping is not applied to the pump, use pipe supports as necessary. Supports also prevent the vibration and heat generated along the piping from reaching the pump.
3. The connections on the piping should be assembled carefully, to prevent liquid leakage, air leakage, and air suction.
4. Commercially available connectors and tubing may be used in the piping system. However, for the liquid piping system, they must be designed to prevent leakage during a high-temperature or temperature cycled operation as well as corrosion from the liquid and atmosphere.

## **Liquid piping**

1. Pump port diameters and materials  
The standard material of the pump discharge and suction port is PFA tube. The applicable tube diameters are as follows:

Model	O.D.
FW-20(H)T	3/4"
FW-40(H)T	1"
FW-80T	1"

Use tubing, piping and connectors with diameters corresponding to those of the pump tubes. The inside diameter of the piping connectors and tubing should be larger than those of the discharge and suction ports if possible. *Never install connectors or tubing with smaller diameters than the pump suction and discharge tubing.*

2. The length of the piping should be as short as possible. The number of bends, couplings and valves installed along the piping should also be minimized to keep the piping resistance as low as possible.
3. Design the piping to absorb linear expansion and thus prevent thermal stress onto the pump.

### **■ Points to be observed in suction pipe arrangement**

1. The suction piping should be larger in diameter than the pump port if possible, and short in length. Iwaki Walchem recommends the flooded suction system, if possible, for optimum performance. In the suction lift system, determine the height according to the self-priming capacity of the pump.

\* The suction height differs with the liquid's characteristics, temperature and suction pipe length. For more detailed information, contact Iwaki Walchem Corporation.

2. If necessary, install a filter or strainer with low piping resistance on the suction piping to block the entrance of solid particles or wafer fragments.



**CAUTION!** Wafer fragments inside the pump may get stuck in the bellows and cause damage. If solid matter clogs the pump's valves, internal suction or discharge volume may be affected, disabling the normal checking function.

3. When installing a valve on suction piping, select a valve with a larger orifice than the inner diameter of the pipe. A smaller orifice may result in a larger suction piping resistance or an increased chance for the valve to become clogged with a crystallized substance. Make sure to keep the valve open during pump operation.



**CAUTION!** Operating the pump with the valve on the suction piping closed will cause inward deformation of the bellows.

4. Do not create air traps in suction plumbing.

## ■ Points to be observed in the discharge pipe arrangement

1. The pump discharge load increases with the length of the discharge piping and the number of bends along the pipe. Install a dampener to decrease the load and prevent pulsation.
2. When installing a valve on discharge piping, select a valve with a larger orifice than the inner diameter of the pipe. A smaller orifice may result in a larger discharge piping resistance or an increase chance for the valve to become clogged with a crystallized substance. Make sure to keep the valve open during pump operation. Do not close the valve until the discharge pressure is completely released after the pump is stopped.



CAUTION! Do not close the discharge valve to stop the pump. The resulting impactive pressure may deform the bellows.

3. A filter must be selected to meet the pump type. Filtering area, grain-removing performance and flow characteristics should be taken into consideration in selecting the filter. A desired flow rate may not be achieved if the selection is wrong. Proper filter venting is critical.



CAUTION! The filter should be wetted before running process liquid. A desired flow rate may not be achieved if the filter is not wetted sufficiently. The filter dries out if the process liquid is not supplied for a long time. Read the filter instruction manual for details.

The piping should be designed so that no residual pressure results on the discharge side upon stopping the pump. (For example, filter air elimination should be set full open or a return circuit should be employed to remove residual pressure.)

## ■ Liquid Circulation System Design Recommendations

In typical semiconductor wet process liquids, a catalyst such as H<sub>2</sub>O, O<sub>3</sub> or H<sub>2</sub>O<sub>2</sub> is added to the process liquid. The subsequent reaction generates heat and produces extreme gassing of the liquid. Measures should be taken to reduce the amount of gas laden liquid which can enter the pump chambers. Excessive gas can cause an air lock condition for the pump which may increase the pump stroke rate to unacceptable levels.

For safe and efficient circulation and feeding of liquid, it is necessary to carry out air elimination and take proper safety measures.

### **Air elimination technique**

When air enters the bellows and the pump becomes air locked, the pump stroke rate increases. If the increase is excessive, that is, higher than the specified pump stroke rate, stop the pump or carry out air elimination.

**Plan A (Bubbles are blocked by means of a baffle plate)**

1. In case of flooded suction system  
A baffle plate is set in the overflow tank to separate bubbles from the liquid, thus limiting the air content.
2. In case of suction lift system  
A baffle plate is set in the lower level in the reaction tank. The top of the suction port tube is positioned under the baffle so that bubbles are not drawn into the suction piping with the liquid.

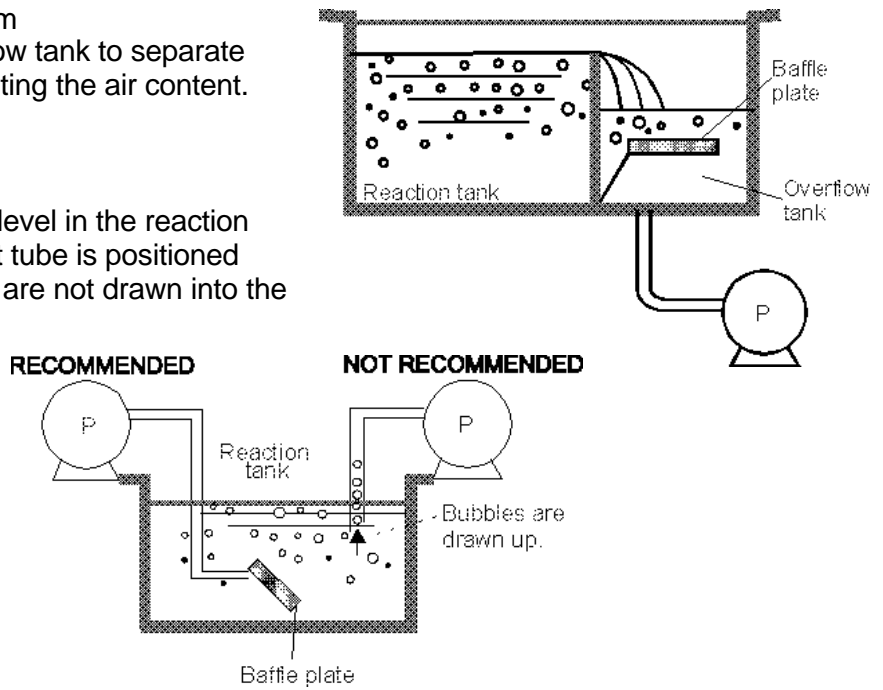

**Plan B (Automatic air elimination with auto valve installed)**

With or without a baffle plate, automatic air elimination should be executed continuously in the system. A valve is used to automatically purge collected air from the filter via an air elimination line back to the overflow tank. For example, the air elimination process is activated every 2 Minutes after the start-up of the pump by opening the auto valve for 10 seconds.

Note 1: Some filters have diameters too small for air elimination. Take the diameter into consideration when selecting a filter.

Note 2: Determine the open period of the auto valve on the basis of the system performance.

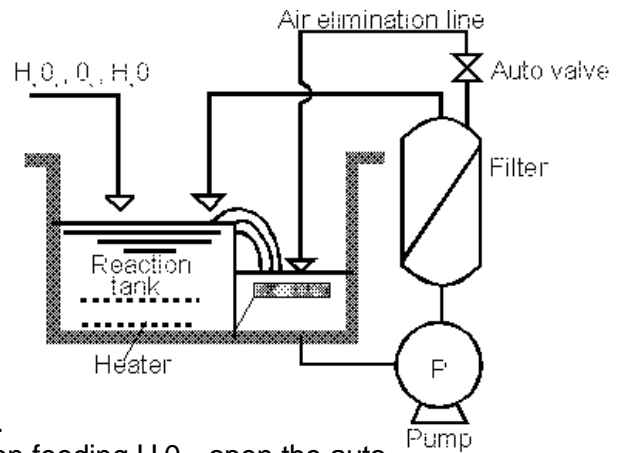

2. If the conditions under which bubbles are predictable, an air elimination technique which fits well with such conditions may be applicable. For example, if bubbles are generated only when feeding  $H_2O_2$ , open the auto valve to carry out air elimination only when  $H_2O_2$  is fed.
3. Another technique is to install an air detection sensor in the suction port area, so that the auto valve is automatically opened by a signal sent out from the sensor and the air elimination operation is initiated.

## Air Piping

It is critical that all pneumatic piping and components be sized according to the porting of the pump. Full port components with matching effective cross-sectional area are recommended.

1. Effective cross-sectional area indicates the capacity to allow air to flow freely. When air is sent through a pipe, the air cannot run totally through the actual cross-sectional area of the pipe due to the negative effect of the piping resistance. The cross-sectional area which represents the total air flow is called the effective cross-sectional area. (The value increases as the capacity to allow air or fluid to flow freely increases.) For the effective cross-sectional area value of the pneumatic device, refer to the manufacturer's catalog of each device.
2. Determination of composite effective cross-sectional area:  
Air devices are connected in series with the pump. It is necessary to determine the composite effective cross-sectional area of the entire system from the sum of the cross-sectional areas of each device.

$$\frac{1}{S^2} = \frac{1}{(S1)^2} + \frac{1}{(S2)^2} + \dots + \frac{1}{(Sn)^2}$$

S = Composite effective cross-sectional area for entire system  
Si = Effective cross-sectional area of each part (ie. S1, S2, Sn)

Effective cross-sectional area of air device/air pipe: See the catalog issued by each manufacturer.

Model	Minimum composite effective cross-sectional area
FW-20(H)T	13.2 mm <sup>2</sup>
FW-40(H)T	19.5 mm <sup>2</sup>
FW-80T	30.0 mm <sup>2</sup>

3. Diameter of pump connection port:  
The diameter of the connection port on the air supply side is as follows:

Model	Pipe Thread Size
FW-20(H)T	1/4" PTF
FW-40(H)T	3/8" PTF
FW-80T	1/2" PTF

The inside diameter of the piping connectors and tubing should be larger than those of the pump connection port, if possible. Never install connectors or tubing with smaller diameters than the pump.



	FW-20(H)T	FW-40(H)T	FW-80
Pipe length shorter than 1m	Inner diameter larger than 8mm	Inner diameter larger than 10mm	Inner diameter larger than 12mm
Pipe length 1 to 3m	Inner diameter larger than 9mm or for the use of quick exhaust valve	Inner diameter larger than 12mm or for the use of quick exhaust valve	For the use of quick exhaust valve
Pipe length longer than 3m	Contact Iwaki		

2. Install a relief type regulating valve:  
Fluctuation of supply air pressure results in fluctuation of the pump stroke rate as well as discharge volume. Install a regulating valve to maintain the air pressure at a fixed level. Select the regulator based on the air consumption rate of the pump. Pressure drop rating of the regulator should be less than 2.8 PSI (0.2 kgf/cm<sup>2</sup>).
- 3 Install a safety valve:  
Install a safety valve after the air pressure regulator to prevent the supply air pressure from exceeding recommended maximum ratings. (see Specifications table)
4. Installation positions of regulating valve and 4-way solenoid valve.  
Install these valves as close to the pump as possible, in consideration of operating efficiency and pressure loss. Be sure to select valves that meet the air consumption rate of the pump. All pneumatic components should be full port, unrestricted style. Install solenoid valves in an area where vapors or liquids cannot harm them.
5. Installation of air exhaust port:  
The exhaust ports of the air circulation system and the 4-way solenoid valve must be installed in correct positions so that the exhaust air is released into the open air.



**CAUTION!** Narrowing the air exhaust port may restrict the air exhaust out of the pump. As a result, the bellows may fail prematurely.

6. Minimize air exhaust noise:  
To minimize the noise of air exhaust, connect the exhaust port with a duct or attach a silencer on the exhaust port. Use full porting and do not use sound dampening devices that restrict the exhaust of air from the air chambers.

Model	Supply air pressure	Stroke speed	Sound level
FW-20(H)T	71.1 PSI (5.0kgf/cm <sup>2</sup> )	120 spm	70.7 dB (A)
FW-40(H)T		80 spm	71.7 dB (A)
FW-80T		80 spm	74.0 dB (A)

7. Installation of multiple pumps:  
The total air consumption of pumps installed on a common air supply line must be considered to ensure adequate air volume/pressure supply. The diameter of the pipe must be determined taking into consideration the total number of pumps and total air consumption.
8. Recommended use of quick exhaust valve:  
As shown in the figure below, the air exhausted out of the pump flows out of the system via the exhaust port of the electromagnetic valve.

Depending upon the liquid handled, some permeated gas may be mixed into the exhaust air. (The inside of the 4-way solenoid valve may be corroded and damaged by such permeated gas.) In such a case, install a quick exhaust valve between the pump and the 4-way solenoid valve. The air will be exhausted through the exhaust port of the quick exhaust valve. (A limited volume of air will be exhausted through the 4-way solenoid valve.)

Note: The pump may be operated without quick exhaust valves, however air exhaust lines should be kept as short as possible with no restrictions to reduce piping resistance.

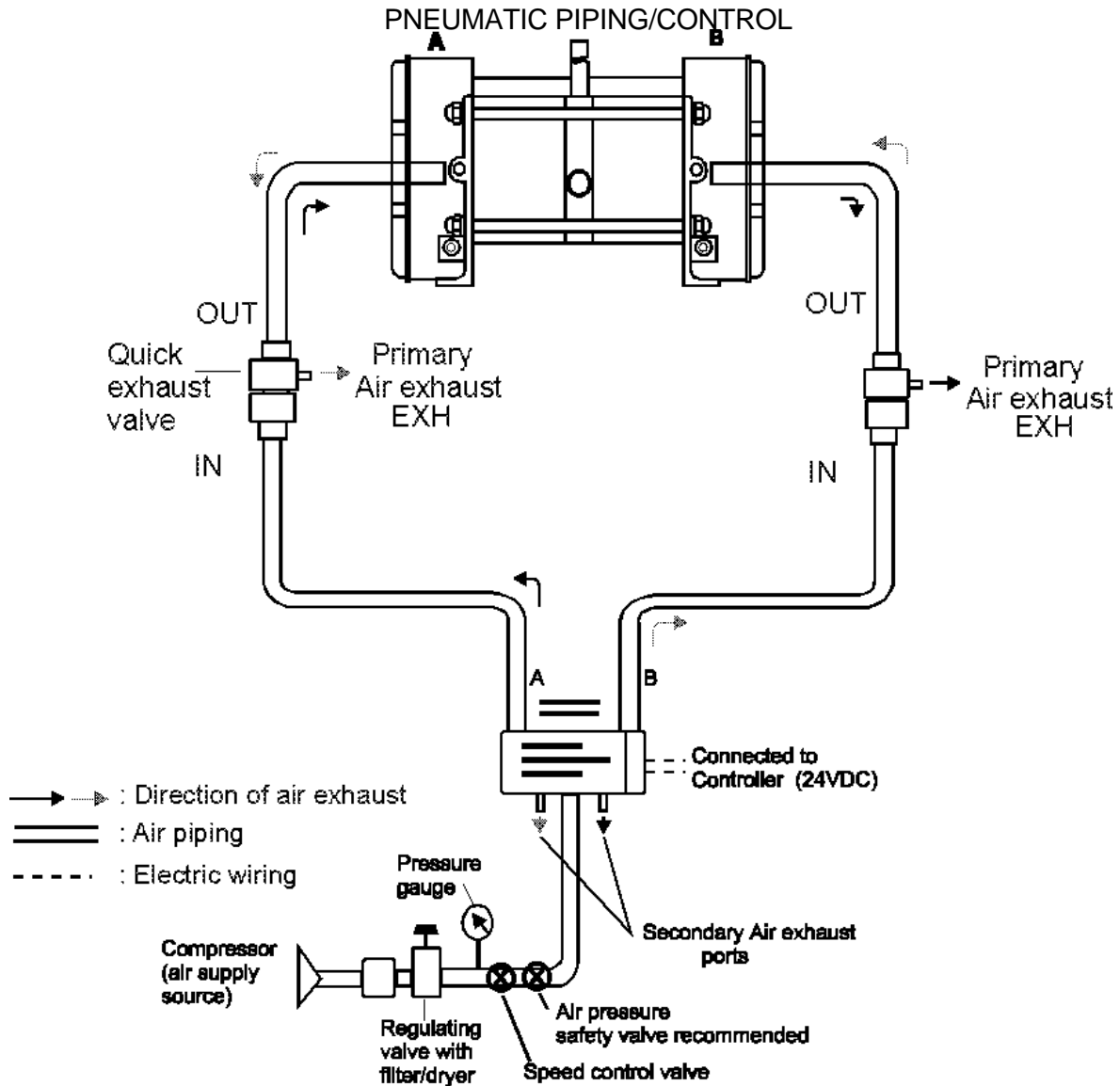

## ■ Wiring instructions

### General

- A. Extension of leak detector electrode wire:  
Keep the resistance value at 5K ohms or below. A resistance greater than the above may make it impossible to detect a conductivity change between the leak detection electrodes. (This is dependent on the controller system.)
- B. Wiring of proximity sensor:  
Isolate the wires of the proximity sensor from the power line or other high-voltage cable. They should not be installed in the same duct or in the same conduit, otherwise the sensor may malfunction. When extending the wire, if it is not extended beyond 100 ft (30m), use 22 AWG wire. If the extension is for more than 100 ft (30m), use a wire with a conductive resistance of 100 ohms/km or less.

### For Use with Host PLC, Computer

Contact Iwaki Walchem to discuss installation and wiring details for use with a PLC or host controller system.

In general, the control system should provide the following pump and system features.

- Control of 5 port, 4 way solenoid valve for proper switching of air supply to pump
- High speed (overspeed) limitation protection
- Slow speed (time-up) monitoring
- Leak detection alarm system (if applicable)
- Filter/air bleed system

The control system should ideally include these additional features:

- Pump stroke totalizer
- Pump stroke rate display (can be translated into flowrate display)
- Pressure monitoring and regulating system
- Slow speed start-up or drain cycle capability

### Wiring for Iwaki Walchem AC-1 Controller

For complete details for use with an AC-1 controller, refer to the AC-1 instruction manual. The following information is supplied as reference.

#### *Wiring for 4-way solenoid valve*

Connect the two wires from the 4-way solenoid valve to terminals no. 1 (+) and 2(-) of the controller. Terminals no. 1 and 2 of the AC-1 controller have polarity, but the standard Iwaki Walchem 4-way solenoid valve has no polarity. Some types with a built-in surge suppressor have polarity, which requires special attention to the wiring polarity.

### Wiring for proximity sensor



**CAUTION!** The proximity of the F series pump have three leads. Faulty wiring may cause the proximity sensor to short circuit. Carry out the wiring carefully and accurately.

- Connect the leads of proximity sensor A with terminals 6, 7, and 8 on the controller.
- Connect the leads of proximity sensor B with terminals 3,4, and 5 on the controller.
- Symbols A and B are arbitrary. The A and B may be interchanged. However, consistency between sensor and air supply lines is necessary.

FW series	Note	AC-1 Terminals
Black	0V	3,6
White	Output	4,7
Red	Power Source (10-30VDC)	5,8

**WARNING!** A standard proximity sensor cannot be used when a flammable liquid is used. Consult factory for details.

### Wiring for Alarm Output 1

- Connect terminals 13 & 14 to use leak detection alarm circuit
- If the leak detection probes fluid in the pump air chambers, the circuit is closed. The red LED (bellows)indicator is illuminated, power to the solenoid valve discontinued and alarm output 1 is activated.

### Wiring for Alarm Output 2

- Connect terminals 11 and 12 to use the time-up function alarm circuit.
- If the time set in the timer is exceeded due to suspended operation or reduced stroke rate of the pump, the yellow time-up indicator (Time-Up) turns on. Simultaneously, the alarm output 2 is activated.

## 7 Operation

---

Carry out the following preparatory steps when starting pump operation for the first time after installation or after a long suspension of the pump operation.

1. Confirm that all liquid connectors along the liquid piping system are fastened tightly.
2. Confirm that the valves on the suction and discharge piping (if applicable) are fully opened.
3. Confirm that the tank or bath has been filled with liquid. Allow the liquid to fill the entire piping system.
4. Confirm that the filter has been properly wetted. Follow the description in the filter instruction manual.
5. For initial installation start-up, a trial run using DI water is recommended. Confirm that no abnormal condition exists before starting the practical operation of the pump and system.

### ■ Operation procedure

Following is a description of the operation and adjustment of the pump using the AC-1 controller. (For pump operation using the FD-1, or SC-1 type controller, refer to the instruction manual of the selected controller.)

#### **Pump start-up**

1. Supply air to the pump by opening the supply valve. Adjust the air supply regulator to 25 PSI.
2. Turn on the power switch of the controller. The pump will start operation and the green Operation indicator LED on the controller will start flashing.
3. Adjustment of pump speed and flow rate is ideally achieved by regulating the air volume **supply** to the pump via a bleed valve. Pump speed may also be adjusted by the air pressure regulator. Never exceed maximum settings for the specific pump model.

#### **Pump stopping**

1. Turn off the power switch of the controller.  
The pump will stop operation and the 'Operation' indicator LED will go out.
2. Make sure the discharge side valve, if applicable, is open upon stopping the pump.  
 CAUTION! Do not close the discharge side valve to stop the pump.
3. Make sure the system does not allow residual pressure to remain on the discharge piping upon the stopping of the pump.

## 8 Troubleshooting Guide

Trouble	Causes	Countermeasures	Inspection & Check Points
Pump does not operate.	Faulty operation of 4-way solenoid valve	<ul style="list-style-type: none"> <li>Inspect and repair or replace.</li> </ul>	<ul style="list-style-type: none"> <li>Install quick exhaust valves if damaged by corrosive gas.</li> </ul>
	Wrong wiring or disconnection in proximity sensor	<ul style="list-style-type: none"> <li>Inspect and correct wiring.</li> <li>Replace if shorted.</li> </ul>	<ul style="list-style-type: none"> <li>Check if the three wires are arranged as in the manual.</li> <li>Check air piping &amp; wiring orientation.</li> </ul>
	Bellows are damaged	<ul style="list-style-type: none"> <li>Replace bellows (If clamp type).</li> </ul>	<ul style="list-style-type: none"> <li>Check if supply air pressure is within the specification.</li> <li>Check if the pump stroke speed is within the specification.</li> <li>Check if liquid temperature is within the specification.</li> <li>Check if residual pressure is removed upon pump stoppage.</li> <li>Check for narrow &amp; long air piping.</li> <li>Check for restricted suction pipe.</li> </ul>
	Increased discharge pressure	<ul style="list-style-type: none"> <li>Inspect filter and replace it.</li> <li>Discharge side valve is closed.</li> </ul>	<ul style="list-style-type: none"> <li>Check filter for clogging or dry-up.</li> <li>Check if filter is sufficiently wetted.</li> <li>Open discharge side valve.</li> </ul>
	Supply air pressure or volume is reduced.	<ul style="list-style-type: none"> <li>Set back to initial set value (Reset).</li> </ul>	<ul style="list-style-type: none"> <li>Set pressure higher than min. operation pressure for 4-way solenoid valve.</li> <li>Secure a diameter and air flow rate in consideration of the number of pumps installed.</li> </ul>
	Filter is not venting.	<ul style="list-style-type: none"> <li>Check filter vent.</li> <li>Open vent line.</li> </ul>	<ul style="list-style-type: none"> <li>Install an automatic venting system for the filter.</li> </ul>
Pump operates but no liquid is discharged	Valve is clogged with foreign matter (such as fragments of wafer, etc.)	<ul style="list-style-type: none"> <li>Replace pump head.</li> <li>Suction side valve is closed.</li> </ul>	<ul style="list-style-type: none"> <li>Install pump guard filter or the like on pump suction for the filter.</li> <li>Open suction side valve. Check if valve is blocked with crystallized substance.</li> </ul>
	Wear of valve or valve seat.	<ul style="list-style-type: none"> <li>Replace pump head.</li> </ul>	

<b>Trouble</b>	<b>Causes</b>	<b>Countermeasures</b>	<b>Inspection &amp; Check Points</b>
Discharge volume is reduced.	Supply air pressure or air volume is reduced.	<ul style="list-style-type: none"> <li>Set back to initial set value or review air flow rate.</li> </ul>	<ul style="list-style-type: none"> <li>Secure a diameter &amp; Flow rate in consideration of the number of pumps installed.</li> </ul>
	Increased discharge pressure.	<ul style="list-style-type: none"> <li>Review discharge conditions.</li> </ul>	<ul style="list-style-type: none"> <li>Check filter for clogging or dry-up.</li> <li>Check if air is removed from the filter sufficiently</li> <li>Check if discharge side valve is open or restricted.</li> </ul>
	Valve is clogged with foreign matter. Insufficient NPSHa.	<ul style="list-style-type: none"> <li>Replace pump head.</li> <li>Check suction.</li> </ul>	<ul style="list-style-type: none"> <li>Install pump guard filter on the like on pump suction pipe.</li> <li>Check if suction pipe is adequate per manual.</li> </ul>
Liquid leaks.	Bellows are damaged.	<ul style="list-style-type: none"> <li>Replace bellows (if clamp type).</li> </ul>	<ul style="list-style-type: none"> <li>Check if supply air pressure is within the specification.</li> <li>Check if pump stroke speed is within the specification</li> <li>Check is liquid temperature is within the specification.</li> <li>Check if residual pressure is removed upon pump stoppage.</li> <li>Check for narrow and long air piping.</li> <li>Check for restricted suction pipe.</li> </ul>
Excessive air consumption.	Wear of shaft packing.	<ul style="list-style-type: none"> <li>Replace packing.</li> </ul>	
Excessive vibration or noise.	Pump stroke rate is excessively high.	<ul style="list-style-type: none"> <li>Set pump stroke rate Within the specification.</li> </ul>	<ul style="list-style-type: none"> <li>Lower supply air pressure or reduce air flow.</li> </ul>

## 9 Maintenance and Inspection

---

### **WARNING**

- **Wear protectors**  
Make sure to wear protective gear (protective goggles, cap, mask, etc.) when performing maintenance and inspection work.
- **Relieve pressure from piping**  
Release any residual pressure before starting the work.  
Residual pressure in the piping system may pressurize the liquid and cause an unexpected accident.
- **Power OFF**  
Be sure to turn off the power switch before you start any maintenance/repair work concerning the pump. Make sure no one turns on the power switch while work is being done on the pump. If the working site is noisy or under conditions of low visibility, you should display a notice which clearly states “Power OFF (Maintenance)” near the power switch in order to inform other personnel about the situation.

### **Periodic Inspection**

1. Check for a decrease in stroke rate. (This should be done at least once a month.) The stroke rate may be decreased because of air leakage, causing an air consumption increase. Such a condition may be attributed to the wear of the shaft packing. Replace the packing as necessary.
2. Check the torque of the bolts on the housing. (This should be done at least once a month.) First relieve the discharge-side pressure. Stop the pump, wait until the pump cools, then tighten the bolts slowly and carefully.

Model	Fastening torque
FW-20(H)T1	14.7N·m (150kgf·cm)
FW-40(H)T1	19.9N·m (200kgf·cm)
FW-80T1	29.4N·m (300kgf·cm)

3. Inspection of valve assembly and Bellows (Inspect more than once a year.) Valve assembly and bellows are expendable parts. (Life of these parts depends on the chemistry and/or operating conditions.) Inspect the pump whenever performance is decreased, or the operating period exceeds the recommended replacement time.
4. Operation of the pump after a long suspension  
Supply air to the pump (approx. 42.7 PSI (3.0kgf/cm<sup>2</sup>)) and confirm there is no leakage from the pump discharge port before restarting the pump.



---

IWAKI WALCHEM CORPORATION  
5 BOYNTON ROAD HOPPING BROOK PARK HOLLISTON, MA 01746 USA  
TEL: 508-429-1440 FAX: 508-429-1386 E-MAIL: [IWAKIWALCHEM@IWAKIWALCHEM.COM](mailto:IWAKIWALCHEM@IWAKIWALCHEM.COM)  
ON THE INTERNET: IWAKIWALCHEM.COM