

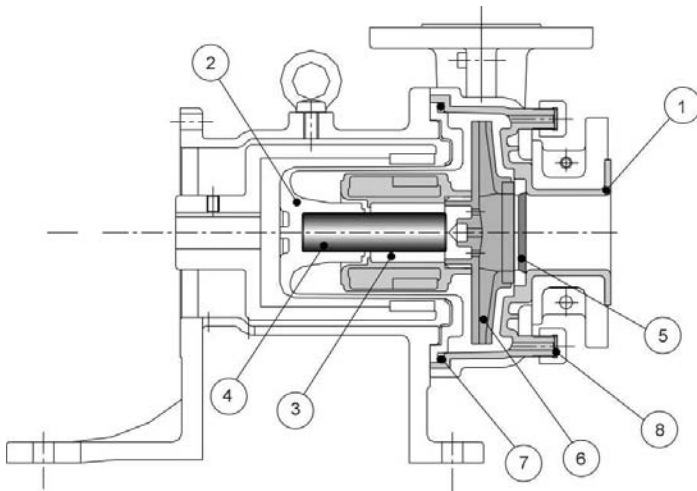

**IWAKI WALCHEM Corporation**

# MDF-L422



- Patented Pinpoint Bearing System allows dry run operation (CF models only)
- Compact design
- Corrosion resistant ETFE internals
- Precision injection molded, individually replaceable, liner components for simple on site maintenance

Part	Material	
	CF	AA
1 Casing Liner	20% carbon reinforced fluoroplastic	
2 Containment shell	ETFE	
3 Bushing	High density carbon	99.8% alumina ceramic
4 Shaft	99.8% alumina ceramic	
5 Thrust collar, inboard		
6 Impeller	20% carbon reinforced fluoroplastic	
	ETFE	
7 O-ring	FKM / EPDM / AFLAS	
8 Gasket		

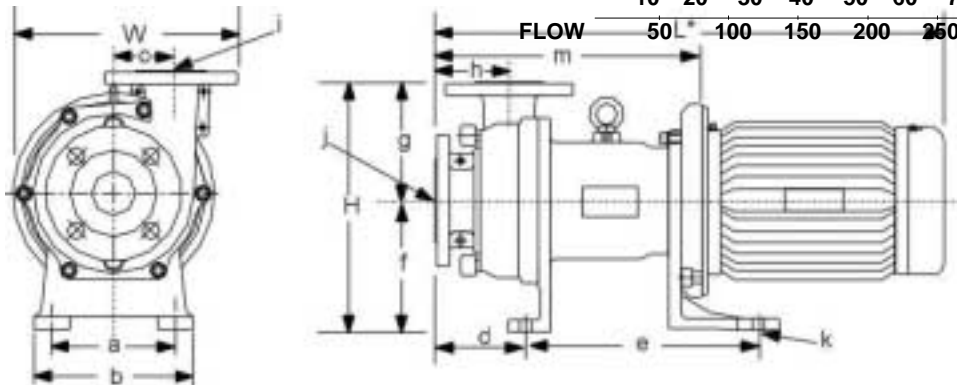
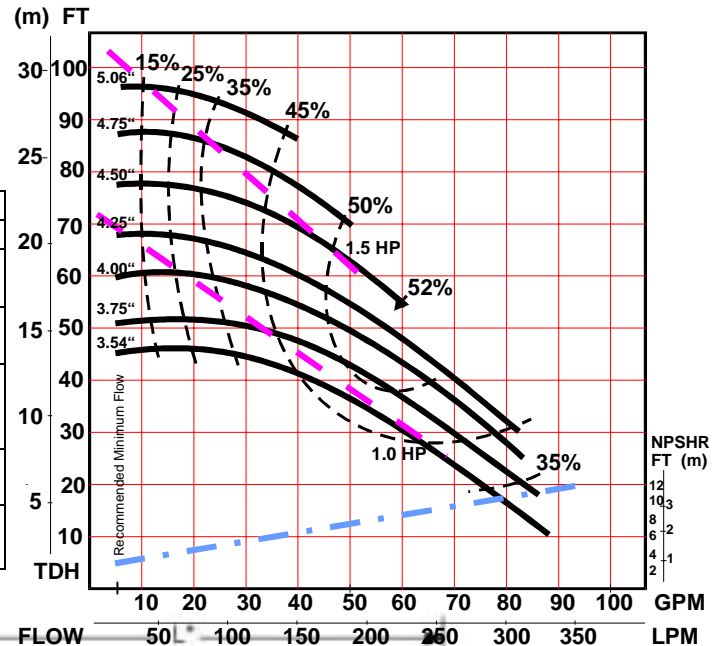

### Dimensions (inches) and Specifications

\* Will vary by motor manufacturer

a	b	c	d	e	f	g	h	i	j	m	k	W	H	L
5.51"	7.09"	2.56"	4.17"	10.83"	6.10"	5.51"	3.43"	1.50"	2.00"	11.38"	0.55"	9.89"	11.61"	22.56"
<b>Connection Sizes</b>			<b>Min Flow/Max Head</b>			<b>Standard Capacity</b>			<b>Max Capacity</b>		<b>Motor/Frame</b>		<b>Pump Weight</b>	
2 x 1.5			5.3 GPM/ 95 ft.			60 GPM/ 55 ft.			88 GPM		2 HP/145TC		33 lbs.	