

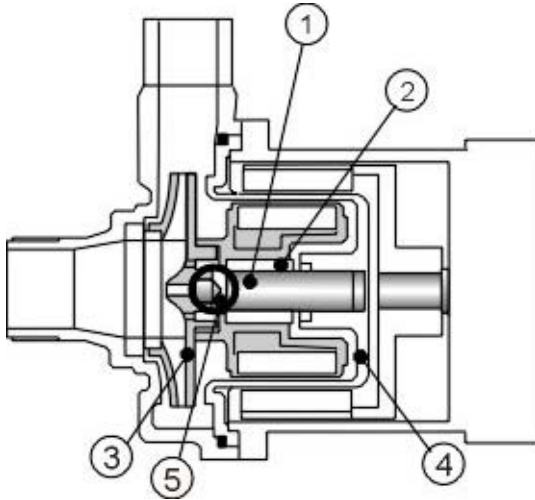

IWAKI WALCHEM Corporation

MDH-425



- Patented Pinpoint Bearing System allows dry run operation
- Rare earth Neodymium magnets
- Compact design
- Flush grooves cool main bearing
- Mounts to standard NEMA C-faced motors
- Glass fiber reinforced polypropylene wetted parts

Part	Material
1 Spindle	Alumina Ceramic, 316 SS
2 Bearing	Carbon, PTFE
3 Impeller	GFRPP
4 Rear Casing	GFRPP
5 Pinpoint Bearing System	Alumina Ceramic

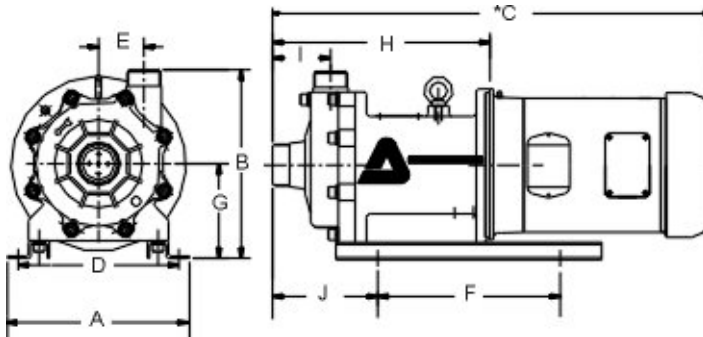
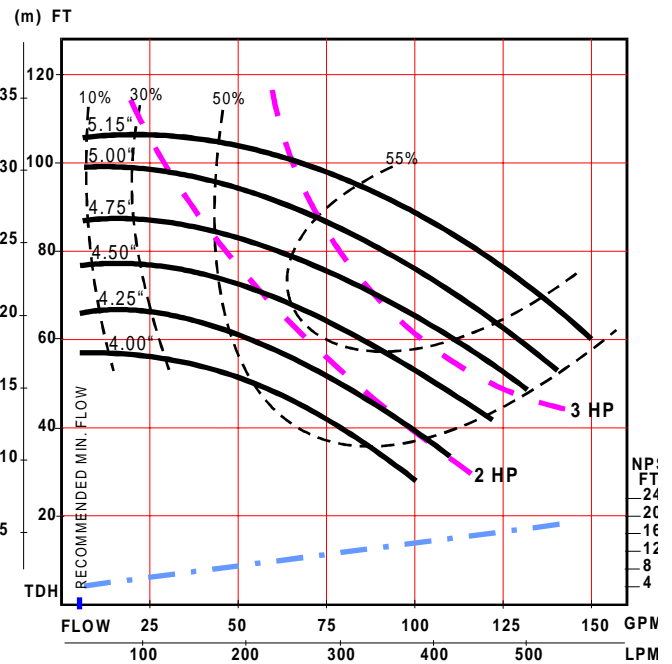

Dimensions (inches) and Specifications

* Will vary by motor manufacturer

HP	NEMA	A	B	C	D	E	F	G	H	I	J
5	184TC	10.24	10.59	23.68	9.06	2.56	10.28	5.31	12.24	3.27	5.91
Connection Sizes	Motor Output (hp)	Motor Speed (rpm)	Max Flow (gpm)	Max Head (ft)	Working Pressure (psi)	Specifi Gravity	Weigh Pump Only (lbs)				
2 x 1½	5	3500	150	102	56	1.2	44				