

FLOMAX 8

SELF PRIMING CENTRIFUGAL PUMPS

Features & Options

- 2" X 2" SELF PRIMING CENTRIFUGAL PUMP
- CLOSE COUPLED TO ELECTRIC MOTOR
- OR PUMPAK ONLY TO MOUNT TO STANDARD NEMA "C" FACE MOTOR 1.5HP, 2HP, 3HP
- FLOWS TO 140 GPM
- PRESSURES TO 100 FEET HEAD
- AVAILABLE IN: CAST IRON, BRONZE OR ALUMINUM CONSTRUCTION
- WITH OR WITHOUT ELECTRIC MOTOR
- IMPELLER—CAST IRON, BRONZE, ALUMINUM OR STAINLESS STEEL
- SHAFT SLEEVE—STAINLESS STEEL TO FIT EITHER 5/8" OR 7/8" SHAFTS
- FASTENERS—STAINLESS STEEL
- SEALS—STANDARD VITON, OPTIONAL SEALS AVAILABLE (CONSULT FACTORY)
- OPTIONS: —ENGINE DRIVES
—PEDESTAL MODELS
—HYDRAULIC DRIVES
—CLUTCHPAKS

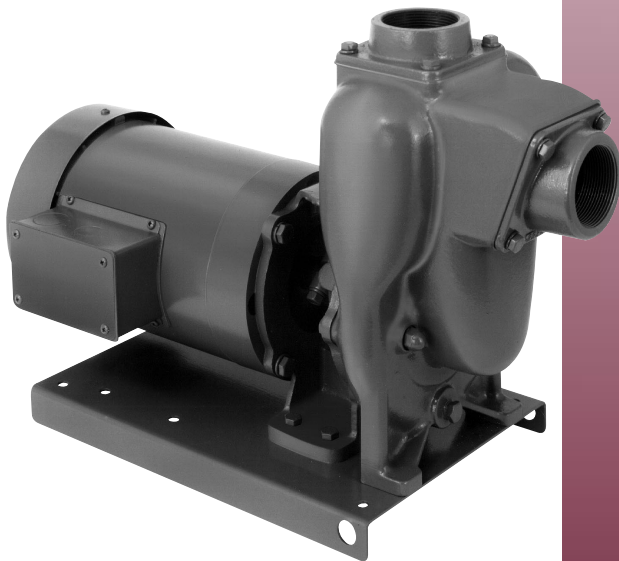

DIMENSIONS

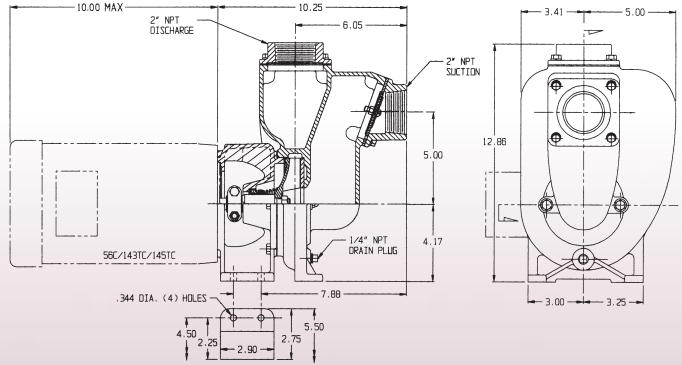

Pump Performance Curves

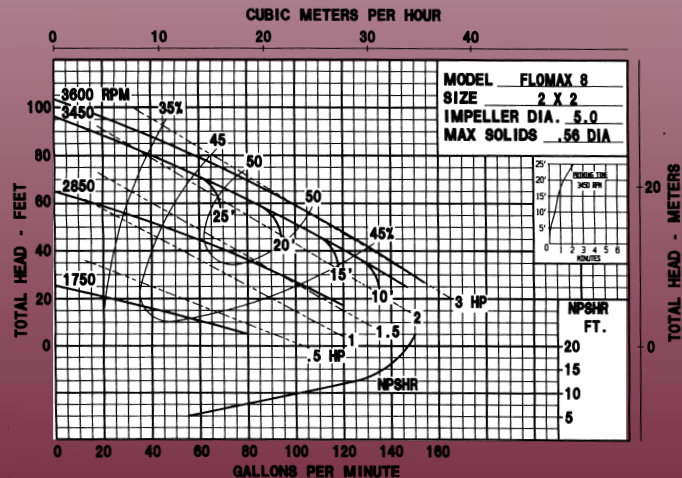
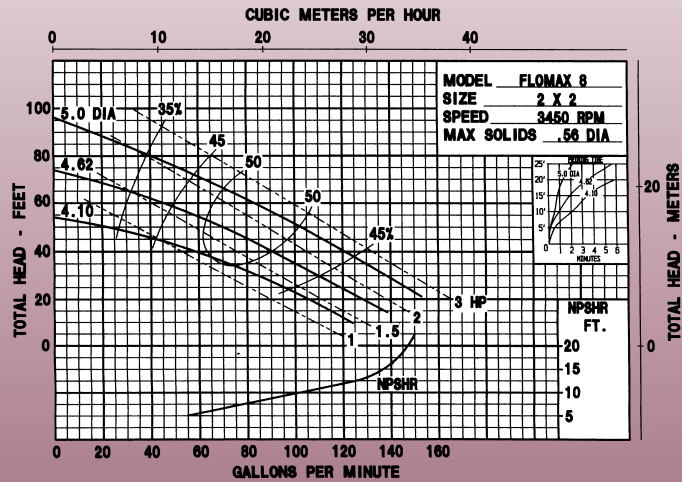

MP PUMPS, INC.
TECUMSEH PRODUCTS COMPANY
(800) 563-8006