

BRONZE CLOSE COUPLED CENTRIFUGAL PUMP

MODEL
104M

OBERDORFER PUMPS
A Subsidiary of Thomas Industries Inc.

PIPE SIZE: INLET 3/4", OUTLET 1/2"



104M-06F26 Pictured

FEATURES

- All Bronze
- Shaft Construction: 416 Stainless, Monel or 316 Passivated Stainless
- Teflon® Barrier Seal to Protect Motor Bearings
- Carbon Face Mechanical Pump Seals
- Viton® (S10) or Teflon® (S11) Pump Seals Available for Solvent Transfer
- Explosion Proof Motors Available
- Will Handle Contaminated Liquids
- Extremely Quiet
- A Standard in the Marine Air Conditioning Industry

LIQUIDS

The special pump alloys used provide corrosion resistance to many liquids including water, water solutions, and a wide range of commercial chemicals. Questions as to the chemical compatibility of special liquids should be referred to the factory.

Viscous liquids with a maximum viscosity of 2000 Saybolt Seconds Universal can be pumped. However, when pumping viscous liquids as compared with water, a reduction in flow and pressure occurs and the required horsepower rate increases.

Liquids heavier than water require additional horsepower in direct proportion to the increase in specific gravity. Liquids contaminated with small solids or abrasives can be handled, but a reduction in mechanical seal life must be expected.

CHARACTERISTICS

This close-coupled pump uses a standard NEMA C-Flange Jet Pump Motor with weld-on base and threaded shaft end to accept the pump impeller. Single phase motors are non-reversible and are wired for the proper pump rotation

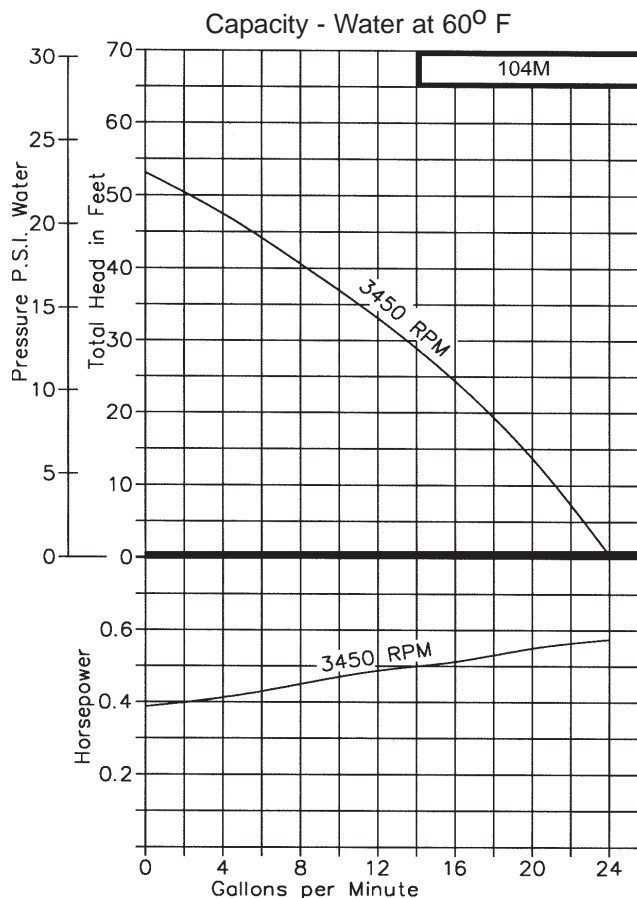

which is counter-clockwise looking at inlet end of pump. See the dimensional drawing on back. Three phase motors must be checked out for proper rotation when pump is installed. Interchanging of any 2 wires in a 3-phase system will reverse motor rotation.

The pump uses a mechanical type shaft seal with a Buna rubber element. It is suitable for water, oils, and some mild solvents and it is limited to 212° F. Viton® seals and Teflon® seals are available for severe solvents, difficult chemicals, and elevated temperatures.

These centrifugal pumps are not self-priming. They must be installed below the liquid level so that the liquid flows to the pump by gravity (flooded suction). However, if a foot valve is used at the beginning of the suction line, and all air is bled from the pump by manual priming, the pump will lift on the suction side up to 15 feet. Such a system relies entirely on the non-leaking foot valve for starting capability.

The flow of a centrifugal pump can be conveniently controlled by a throttling valve in the discharge line without the need for a relief valve. In centrifugal pumps, the horsepower demand will decrease as the pressure increases. Maximum horsepower occurs with a wide open discharge.

* Viton® is a registered trademark of DuPont Dow Elastomers. Viton® or equivalent FKM will be used.
Teflon® is a registered trademark of DuPont. Teflon® or equivalent PTFE will be used.

**MODEL
104M**

BRONZE CLOSE COUPLED CENTRIFUGAL PUMPS

OBARDORFER PUMPS
A Subsidiary of Thomas Industries Inc.

EXPLODED VIEW AND PARTS LIST

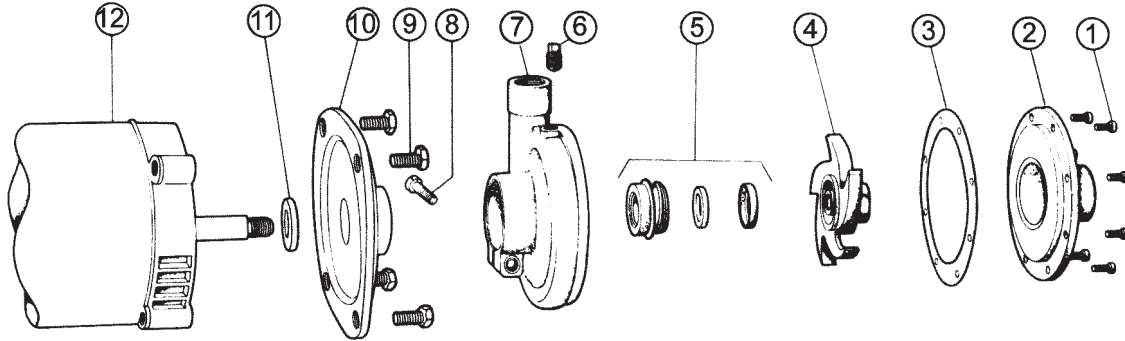

Pump No.	1	2	3 ¹	4 ¹	5 ¹	6	7	8	9	10	11 ¹	12	13 ^{1*}	Repair Kit	
	Screw	Cover	Gasket	Impeller	Seal Assy.	Plug	Body	Screw	Screw	Adapter	Lip Seal	Motor	Set Screw		
	8 Req'd	1 Req'd	1 Req'd	1 Req'd	1 Req'd	2 Req'd	1 Req'd	1 Req'd	4 Req'd	1 Req'd	1 Req'd	1 Req'd	1 Req'd		1 Req'd
104M	5385	5168	5328	6033	32155	7687	7515	5595	5411	6699	6683	---	---	10720 (Single Phase)	
104M-06	5385	5168	5328	6033	32155	7687	9738	5595	5411	6699	6683	---	---	10720 (Single Phase)	
104MP	5385	5168	5328	7432	32155	5395	7515	5595	5411	6699	6683	---	9849	12173 (Three Phase)	

¹ Repair kit contains items 3, 4, 5, 11 & 13.

* Not shown - Impeller set screw for Three Phase motors only.

PUMP & MOTOR OPTIONS

Note: These are the most frequently used pump and motor combinations. If you have other needs, our sales reps can recommend a pump and motor for your application.

Pump No.	HP	SF	Enclosure	Phase	Voltage	Shaft Construction	Motor Item 12
104M-F13	1/3	1.75	ODP	single	115	416	5859
104M-06F13	1/3	1.75	ODP	single	115	416	5859
104M-01F26	1/3	1.75	ODP	single	115 / 230	monel	32273
104M-06F26	1/3	1.75	ODP	single	115 / 230	monel	32273
104M-F17	1/3	1.75	ODP	single	115 / 230	316 passivated	3032
104M-06F17	1/3	1.75	ODP	single	115 / 230	316 passivated	3032
104M-F21	1/3	1.75	XP	single	115 / 230	416	8214
104MP01-F65	1/3	1.75	ODP	three	208 230 / 460	monel	32355
104MP-F57	1/3	1.75	ODP	three	208 230 / 460	416	6996
104M-J19	1/2	1.65	ODP	single	115 / 230	416	5860
104M-J20	1/2	1.65	TEFC	single	115 / 230	416	7976
104MP01-J58	1/2	1.00	TEFC	three	208 230 / 460	monel	33035
104M-01J26	1/2	1.65	ODP	single	115 / 230	monel	32332
104M-J24	1/2	1.65	ODP	single	115 / 230	316 passivated	3031
104MP-M58	3/4	1.15	TEFC	three	230 / 460	416	7967

DIMENSIONS ¹3/4" External Thread also available (104M-06)

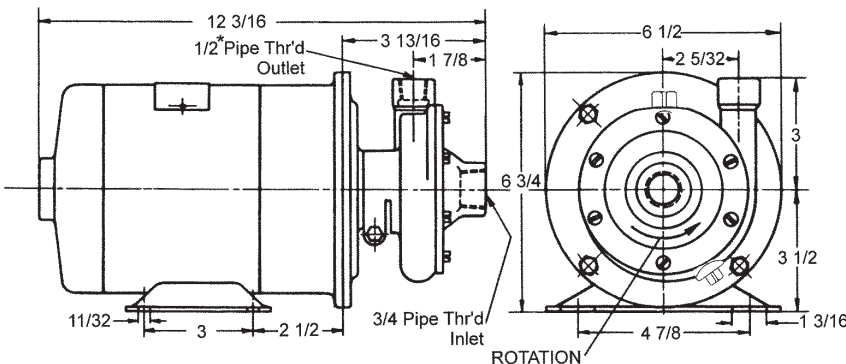

NUMBERING

