

# CLOSE COUPLED BRONZE CENTRIFUGAL PUMP

MODEL  
109MB



OBERDORFER PUMPS  
*A Subsidiary of Thomas Industries Inc.*

PIPE SIZE INLET 1 1/4, OUTLET 1



## FEATURES

- All Bronze
- Stainless Steel or Monel Shaft for Marine Use
- Teflon®\* Barrier Seal to Protect Motor Bearings
- Carbon Face Mechanical Pumps Seals
- Viton(R)\* or Teflon(R)\* Pump Seals Available for Solvent Transfer
- Explosion Proof Motors Available
- Will Handle Contaminated Liquids
- Extremely Quiet
- A Standard in the Marine Air Conditioning Industry

## LIQUIDS

The special pump alloys used provide corrosion resistance to many liquids including water, water solutions, and a wide range of commercial chemicals. Questions as to the chemical compatibility of special liquids should be referred to the factory.

Viscous liquids with a maximum viscosity of 2000 Saybolt Seconds Universal can be pumped. However, when pumping viscous liquids as compared with water, a reduction in flow and pressure occurs and the required horsepower rate increases.

Liquids heavier than water require additional horsepower in direct proportion to the increase in specific gravity. Liquids contaminated with small solids or abrasives can be handled, but a reduction in mechanical seal life must be expected.

## PERFORMANCE

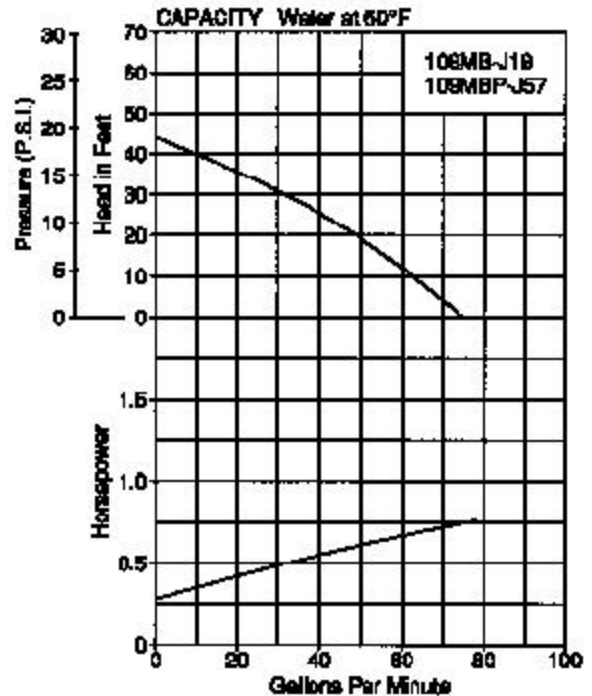

## CHARACTERISTICS

This close-coupled pump uses a standard NEMA C-Flange Jet Pump Motor with weld-on base and threaded shaft end to accept the pump impeller. Single phase motors are non-reversible and are wired for the proper pump rotation which is counter-clockwise looking at the inlet end of the pump. (See the dimensional drawing on back.) Three phase motors must be checked out for proper rotation when the pump is installed. Interchanging of any 2 wires in a 3-phase system will reverse motor rotation.

The pump uses a mechanical type shaft seal with a Buna N rubber element. It is suitable for water, oils, and some mild solvents and it is limited to 212°F and 75 P.S.I. Viton(R)\* seals and Teflon(R)\* seals are available for severe solvents and difficult chemicals.

These centrifugal pumps are not self-priming. They must be installed below the liquid level so that the liquid flows to the pump by gravity (flooded suction). However, if a foot valve is used at the beginning of the suction line and all air is bled from

(continued on back)

\*Viton® is a registered trademark of DuPont Dow Elastomers. Viton® or equivalent FKM will be used.  
Teflon® is a registered trademark of DuPont. Teflon® or equivalent PTFE will be used.

**MODEL  
109MB**

# CLOSE COUPLED BRONZE CENTRIFUGAL PUMP



**OBERDORFER PUMPS**  
*A Subsidiary of Thomas Industries Inc.*

## EXPLODED VIEW & PARTS LIST

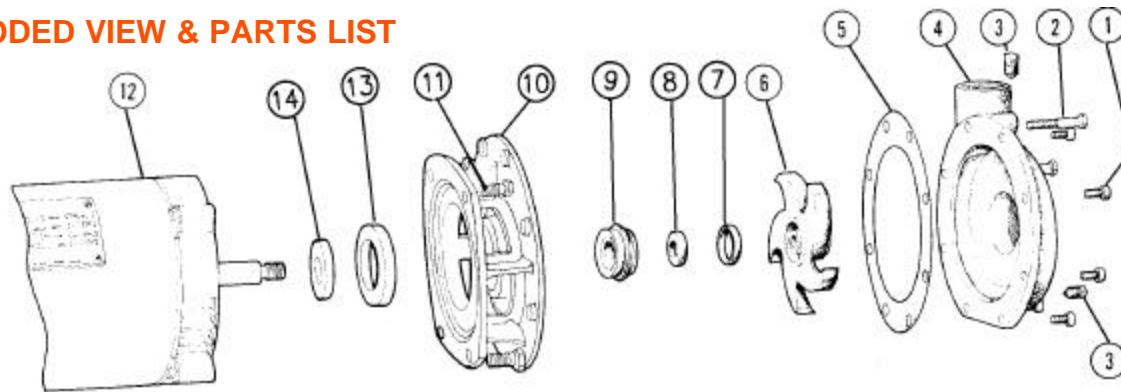

Pump No.	1	2	3	4	5	6	7 <sup>2</sup>	8 <sup>2</sup>	9 <sup>2</sup>	10	11	12	13	14	15 <sup>1</sup>	Repair <sup>3</sup>
	Short Screw	Long Screw	Pipe Plug	Body	Gasket	Impeller	Seal Seat (Pump)	Wear Face (Pump)	Seal (Pump)	Adapter	Screw	Motor	Insert	Seal (Adapter)	Set Screw	Kit
	5 Req'd	3 Req'd	2 Req'd	1 Req'd	1 Req'd	1 Req'd	1 Req'd	1 Req'd	1 Req'd	1 Req'd	4 Req'd	1 Req'd	1 Req'd	1 Req'd	1 Req'd	
109MB	5504	5633	7687	5266	5307	6297	6020	6018	5377	5251	5411	---	6832	6683	---	10721
109MB-J19	5504	5633	7687	5266	5307	6297	6020	6018	5377	5251	5411	5860	6832	6683	---	10721
109MB-01J26	5504	5633	7687	5266	5307	6297	6020	6018	5377	5251	5411	32332	6832	6683	---	10721
109MBP-J57	5504	5633	5395	5266	5307	7196	6020	6018	5377	5251	5411	6998	6832	6683	9849	11065
109MBP01J67	5504	5633	5395	5266	5307	7196	6020	6018	5377	5251	5411	32500	6832	6683	9849	11065

<sup>1</sup> Set Screw for Polyphase motor only. (not shown)

<sup>3</sup> Repair Kits contain items 5,6,7,8,9,14 & 15.

<sup>2</sup> Seal components 7,8, and 9 sold only as seal assy. p/n 32155.

## DIMENSIONS

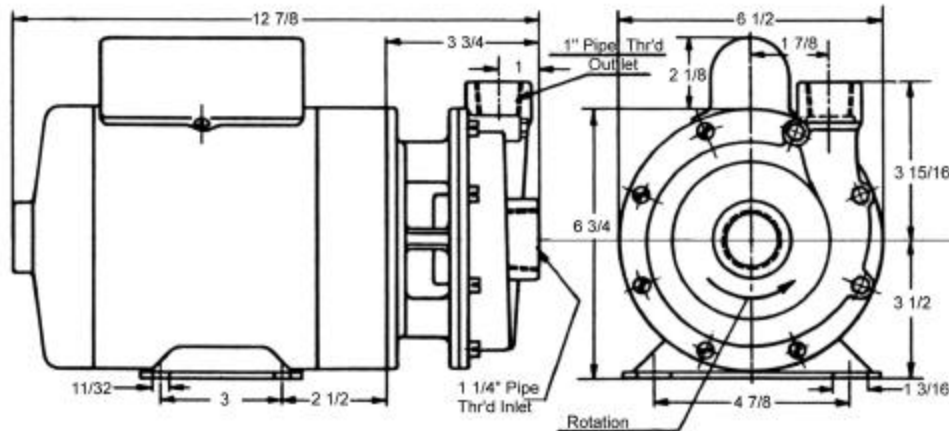

(continued from front)

the pump by manual priming, the pump will lift on the suction side up to 15 feet. Such a system relies entirely on a non-leaking foot valve for starting capability.

The flow of a centrifugal pump can be conveniently controlled by a throttling valve in the discharge line without the need for a relief valve. In centrifugal pumps, the horsepower demand will decrease as the pressure increases. Maximum horsepower occurs with a wide open discharge.