

BRONZE CENTRIFUGAL PUMPS

PIPE SIZE: 1 1/2" INLET, 1 1/4" OUTLET

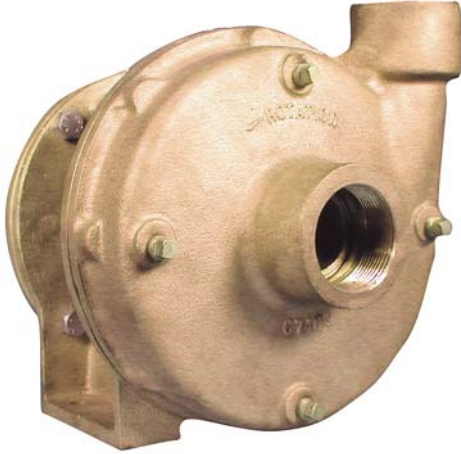

Pump No.	HP at 3450 RPM	Material
83PB	3	Bronze

FEATURES

- All Bronze
- Mechanical Face Type Seal
- Viton(R)* (S10) or Teflon(R)*(S11) Seals Available on Special Order
- Heavy Duty Ball Bearings - Designed for Pulley Drive Applications
- Stainless Steel Shaft
- Field Convertible to Close Coupled Unit Using Standard Keyed Shaft "C" Flange Motor
- May Be Operated with the Shaft Horizontal or Vertical

ROTATION

Because of the centrifugal pump impeller and body design, rotation must be as shown in the dimension diagram (see back). Standard factory rotation is clockwise facing the pump shaft. If the pump is driven in the opposite direction it will pump only a very small amount.

RELIEF VALVE

Since centrifugal pumps are not positive displacement pumps, relief valves are not necessary to protect against high pressure build-up.

SUCTION LIFT

Regular centrifugal pumps have no self-priming capability and must be mounted below the liquid source (flooded suction). Self-priming centrifugal pumps must be primed once at the initial start-up thru the priming plug opening at the top of the pump body. On subsequent starts the pump will automatically prime itself and develop lifting capability of 15 feet or more.

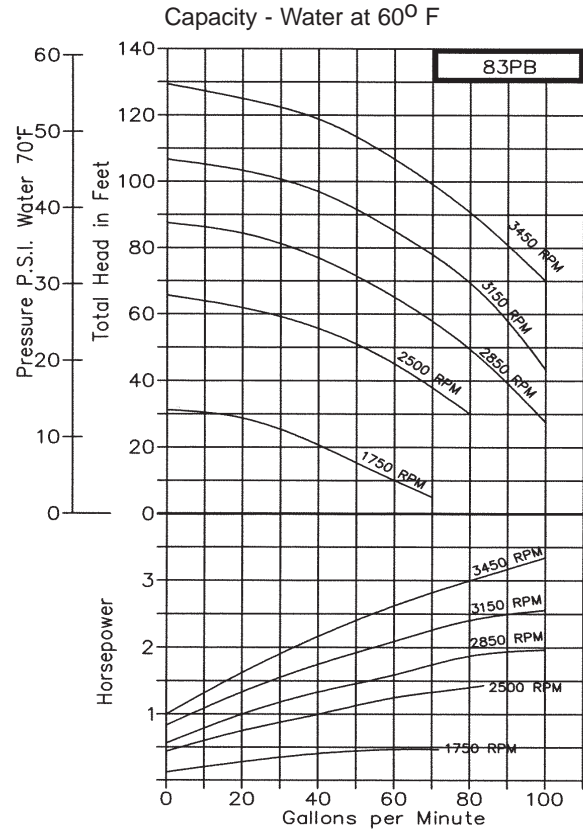

The height of the suction lift should be kept to an absolute minimum and the size of the suction pipe should be equal or larger than the pump inlet port. A foot valve with strainer is recommended at the beginning of the suction line. Self-priming centrifugals must be operated with the shaft in the horizontal position, regular centrifugals may be operated with the shaft horizontal or vertical.

LIQUIDS

Because centrifugal pumps are more efficient at higher shaft speeds, pumping of viscous or thick liquids is difficult. It is possible to lose as much as 40% pump performance when attempting to pump liquids of viscosity equal to S.A.E. 30 oil at room temperature. S.A.E. 30 oil at room temperature has a viscosity of 2000 Saybolt Seconds Universal. More viscous liquids are not recommended for centrifugal pumps.

Heavy liquids can be pumped; however, they demand more horsepower in direct ratio to the weight of water. For example, carbon tetrachloride has a specific gravity of 1.6 which means it is 1.6 times heavier than water and horsepower required is 1.6 times water horsepower.

Bronze pumps are suitable for most common liquids in the PH-range from 4 to 11. The temperature limit for bronze pumps is 212°F, higher temperatures are possible with Viton(R)* or Teflon(R)* seals.

*Viton(R) is a registered trademark of DuPont Dow Elastomers. Viton(R) or equivalent FKM will be used.
Teflon(R) is a registered trademark of DuPont. Teflon(R) or equivalent PTFE will be used.

BRONZE CENTRIFUGAL PUMPS

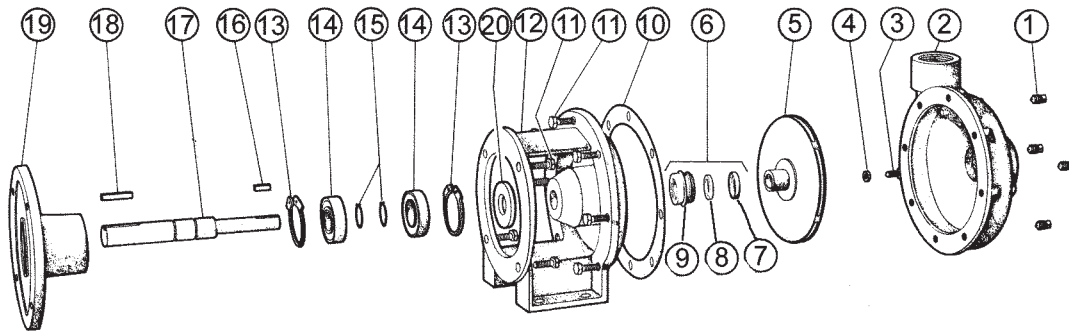

Pump No.	1	2	3	4	5 ¹	6 ¹	7 ²	8 ²	9 ²	10 ¹	11	12	13	14	15	16	17	18	19	20	Repair Kit
	Pipe Plug	Body	Screw	Lock-washer	Impeller Assembly	Seal Assembly	Seal Seat	Seal Wearface	Seal Head	Gasket	Screws	Adapter	Retaining Ring	Ball Bearing	Retaining Ring	Key	Shaft	Key	Bearing Plate	Slinger	
83PB	4 Req'd	1 Req'd	1 Req'd	1 Req'd	1 Req'd	1 Req'd	1 Req'd	1 Req'd	1 Req'd	1 Req'd	12 Req'd	1 Req'd	2 Req'd	2 Req'd	2 Req'd	1 Req'd	1 Req'd	1 Req'd	1 Req'd	1 Req'd	10953
83PBS-10	5395	7585	7656	7395	32353	32346	7427	7426	5377	7425	5411	7586	6053	5884	5885	7428	7455	6845	7587	7447	12267
83PBS-11	5395	7585	7656	7395	32427	32211	N/A	N/A	N/A	7425	5411	7586	6053	5884	5885	7428	7455	6845	7587	7447	12268

¹ These parts are included in the Repair Kit.

² Seal parts sold only as seal assembly - item 6.

DIMENSIONS

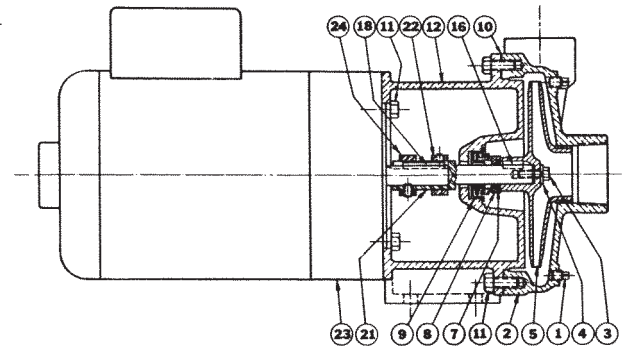
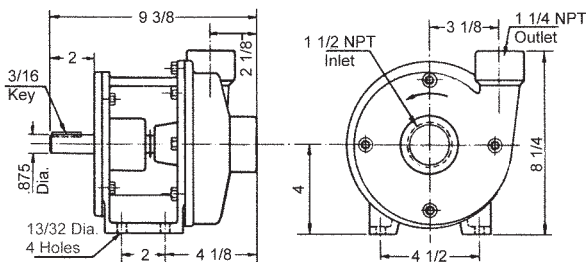

INSTRUCTIONS FOR CONVERTING FROM PEDESTAL MOUNT TO CLOSE COUPLED MOTOR VERSION (from 83P to 830 USY, etc.)

To accomplish change-over, Conversion Kit No. 10963 is required.

PROCEED STEP-BY-STEP AS FOLLOWS:

- 1) Unscrew eight cap screws (11) and remove pump body (2).
- 2) With a 7/16 socket wrench, unscrew one cap screw (3) from shaft and remove impeller (5) and lockwasher (4). Also remove key (16).
- 3) Using two screwdrivers, pull ceramic face (8) with rubber seat ring (7) away from seal head (9) and remove them from shaft.
- 4) Unscrew four cap screws (11) and remove adapter (12) from motor (23) - or from bearing plate (19) on pedestal pumps.

ASSEMBLE PUMP TO MOTOR STEP-BY-STEP AS FOLLOWS:

- 1) Insert key (18) into pump shaft (21) and slide pump shaft (21) onto motor shaft as far as it will go.
- 2) Slide collar (24) -with a 3/8 long set screw-onto pump shaft so that set screw will line up with 1/4" hole in shaft. Tighten set screw onto motor shaft. Slide collar (22) onto pump shaft. Tighten set screw firmly against top of key (18).
- 3) Press seal head (9) into adapter casting (12) using a

sealer such as Permatex between outside diameter of seal head and casting bore. When shipped from factory, the seal head is usually pressed in place already.

- 4) Mount adapter casting (12) to motor using four cap screws (11).
- 5) Squirt a drop of oil on lapped surface of ceramic wear face (8) and slide wear face over pump shaft (21) against carbon ring of seal head (9).
- 6) Apply some oil to pump shaft (21) and slide rubber seat ring (7) into counterbore of ceramic wear face (8). Be careful that the rubber ring is not being cut by the edges of the keyslot.
- 7) Insert key (16) into pump shaft.
- 8) Slide impeller (5) onto shaft and secure with lockwasher (4) and cap screw (3). A 7/16 socket wrench is required for this operation.
- 9) Place gasket (10) on adapter flange and assemble pump body (2) using eight cap screws (11).
- 10) If a three-phase motor is used, make sure that during the electrical hook-up the motor rotation corresponds with the proper pump rotation. Refer to rotation arrow on pump body. Single phase motors are permanently wired for proper rotation.