

ROTARY GEAR PUMP BRONZE

1 1/4" NPT PORTS

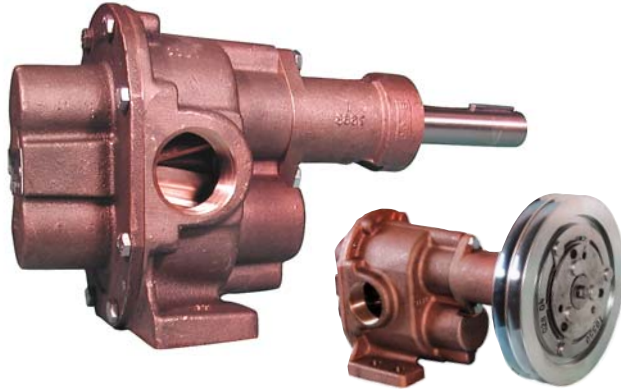

N11HDM WITH CLUTCH

STANDARD			
Pump No.	Seal		Conversion Kit No.
	Type	Material	
N11HDP	Packing	Acrylic-Graphite	11021
N11HDL	Lip	Viton(R)*-Teflon(R)*	11023
N11HDM	Mechanical	Buna N-Ceramic	11025

SPECIAL			
Pump No.	Seal		Conversion Kit No.
	Type	Material	
N11HDP-1	Packing	Teflon	11022
N11HDL3	Lip	Buna N	11024
N11HDM3	Mechanical	Viton(R)*-Ceramic	11026

FEATURES

- All Bronze Castings and Stainless Steel Shafts
- Sealing Arrangement Interchangeable in Field with Proper Kit
- Outboard Ball Bearing Support
- Self Lubricating Carbon Bearings
- Electric Clutch (Options)

SERVICE WEAR FACTORS

SPEED - High speed accelerates wear. For longer service life, keep speed as low as possible. Pump speeds above 900 R.P.M. not recommended except for intermittent duty and pressures below 100 p.s.i.

PRESSURE - High pressure accelerates wear. For longer service life keep pressure as low as possible.

LIQUID TEMPERATURE - High temperature accelerates wear. Keep as close to room temperature as possible.

LIQUID CONTAMINATION - Impurities like fine abrasive silt or sand accelerate wear. Keep liquid as clean as possible.

LIQUID LUBRICITY - Lubricants increase service life many fold. Use lubricant additives whenever possible.

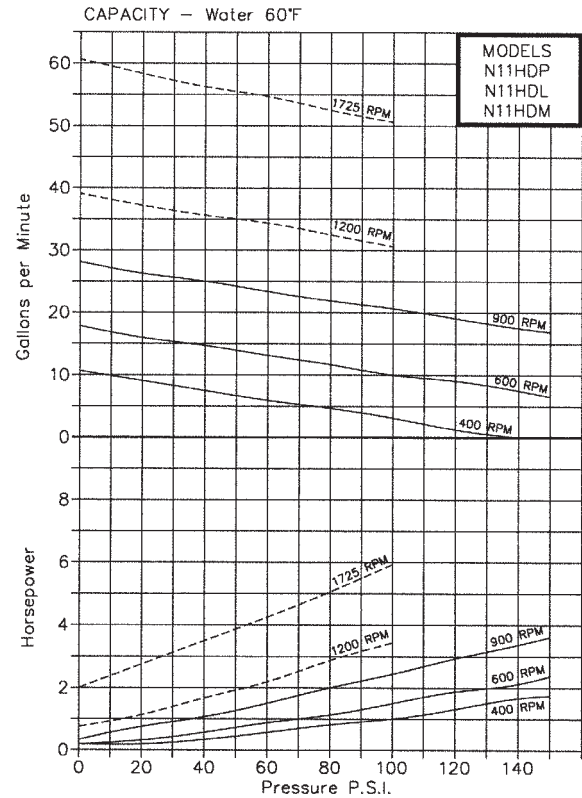

Note: Dotted lines(---) recommended for intermittent duty only due to accelerated wear at higher speeds and pressures.

NOISE - Large gear pumps are inherently noisy due to metal to metal gear contact. Make installations far removed from offices or other relatively quiet people areas. Some noise reduction can be realized by lowering pump speed and use of isolation mounts and lines, usually the small amount of noise reduction achieved does not justify the effort and expense.

DRIVE & ALIGNMENT- Direct drive is the recommended drive arrangement. This pump is suitable for belt drive applications without needing pillow block bearings to achieve acceptable pump life. Correct alignment is absolutely essential for satisfactory pump life. Recheck alignment after piping has been connected to the pump. Electric clutch versions available.

SEAL CONVERSION KITS

Seal conversion kits, illustrated (on back) are designed for quick removal and replacement. In each case, seal housings are fastened to pump bodies by means of 2 bolts, item 13. **IMPORTANT** - before attempting to remove a seal housing containing seal components by sliding them off the pump shaft, be sure to unlock the 2 set screws locking the ball bearing inner race to the pump shaft. The ball bearing is identified as item 20. Also, before attempting to slide the seal housing from the pump shaft, remove all burrs, scale, and projections that could be formed by fretting corrosion.

* Viton® is a registered trademark of DuPont Dow Elastomers. Viton® or equivalent FKM will be used.
Teflon® is a registered trademark of DuPont. Teflon® or equivalent PTFE will be used.

MODELS

N11HDP
N11HDL
N11HDM

ROTARY GEAR PUMP BRONZE

EXPLODED VIEW AND PARTS LIST

Pump No.	1	2	3*	4*	5*	6*	7*	8*	9*	10	11*	12*	13
	Cover	Screw	Snap Ring	O-Ring	Bearing	Drive Gear	Drive Shaft	Idle Shaft	Idle Gear	Body	O-Ring	Packing Ring	Screw
	1 Reqd	8 Reqd	4 Reqd	1 Reqd	4 Reqd	1 Reqd	1 Reqd	1 Reqd	1 Reqd	1 Reqd	1 Reqd	4 Reqd	2 Reqd
N11HDP	9333NN5N	5393	7651	9797-158	5108	9833	7366	7652	9834	9331NG7N	6515	7624	5916
N11HDL	9333NN5N	5393	7651	9797-158	5108	9833	7366	7652	9834	9331NG7N	9797-224	---	6827
N11HDM	9333NN5N	5393	7651	9797-158	5108	9833	7366	7652	9834	9331NG7N	9797-224	---	6827

Pump No.	14	15	16	17	18*	19	20	21	22*	23	24	25*	26	Repair Kit No.
	Nut	Gland	Screw	Seal Housing	Lip Seal	Snap Ring	Ball Bearing	Key	Lip Seal	Seal Housing	Ring	Seal Assy.	Dowel Pin	
	2 Reqd	1 Reqd	2 Reqd	1 Reqd	1 Reqd	2 Reqd(P) 1 Reqd (L&M)	1 Reqd	3 Reqd	1 Reqd	1 Reqd	1 Reqd	1 Reqd	2 Reqd	
N11HDP	8395	7451	9905	7449	6710	7372	7368	6518	---	---	---	---	8597	11003
N11HDL	---	---	---	---	---	7372	7368	6518	7262	7365	---	---	8597	11005
N11HDM	---	---	---	---	---	7372	7368	6518	---	7365	7651	32315	8597	11007

*Repair Kits include parts 3, 4, 5, 6, 7, 8, 9, 11, 12, 18, 22 & 25

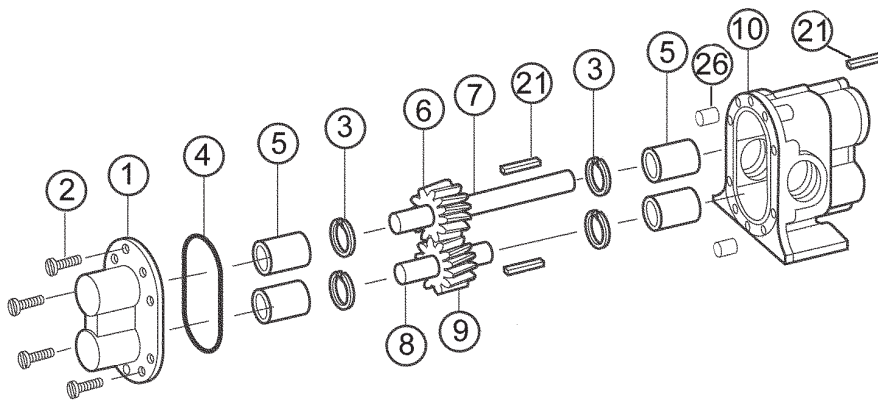

CLUTCH DRIVE OPTIONS

Pump No.	Clutch Drive Options	Clutch Body	Clutch Coil	Clutch Assy	Pump Repair Kit	23	7
						Seal Housing	Drive Shaft
N11HDM-E12	Gear Pump, Mechanical Seal, with 12V Clutch	7227	7224	32238	12013	9169-1	7722-1
N11HDM-E24	Gear Pump, Mechanical Seal, with 24V Clutch	7227	9902	33066			
N11HDM-E32	Gear Pump, Mechanical Seal, with 32V Clutch	7227	7225	32239			

DIMENSIONS

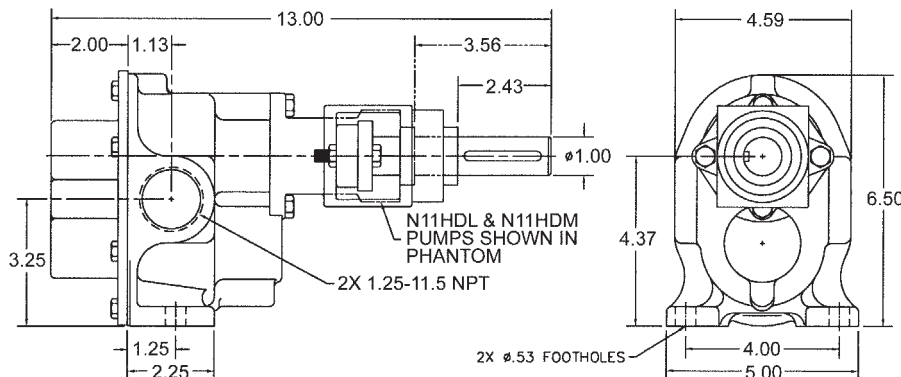

ADDITIONAL SEAL OPTIONS

Pump No.	Seal Options	22*	25*	Repair Kit
		Lip Seal	Seal Assy.	
		1 Req'd	1 Req'd	
N11HDLS3	Buna Lip Seal	6500	---	11006
N11HDSM7	Viton Mechanical	---	32372	11008

PACKING SEAL END

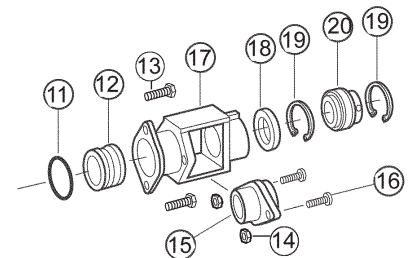

LIP SEAL END

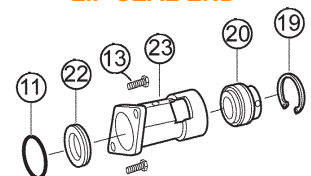

MECHANICAL SEAL END

