

# BRONZE PEDESTAL ROTARY GEAR PUMPS

BRONZE BEARINGS



## OBERDORFER PUMPS

A Subsidiary of Thomas Industries Inc.

**MODEL  
N7000L  
N7000LR  
SERIES**

### MODEL N7000L - 3/4" NPT PORTS

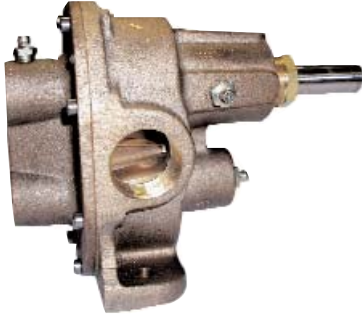

### MODEL N7000LR

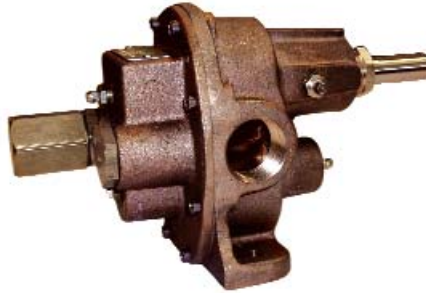

#### FEATURES

- Bronze corrosion resistant castings
- Special cast bronze helical gears for quiet operation
- Stainless steel shafts & fasteners
- Synthetic braided compression packing (with Teflon® dispersion) is standard
- Optional lip seals are available
- Positive displacement flow
- Bronze bearing surfaces with grease fittings

#### MOUNTING AND DRIVE ARRANGEMENT

Pumps should be mounted on a rigid base and properly aligned with the motor. Direct drive via flexible shaft coupling is the preferred method. When a belt drive is needed, additional support is necessary to absorb the added pulley load. This can be accomplished in two ways:

- 1) Use the standard pump arrangement by adding an independently supported jackshaft (see figure 2 below) or use kit 79P
- 2) When space is an issue, use an optional "long shafted" pump and add a properly shimmed pillow block bearing (see figure 1).

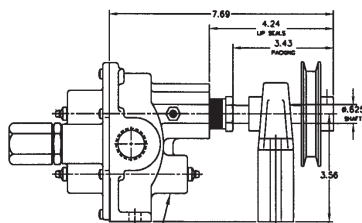

OPTIONAL N7000L(R)-02  
SERIES PUMP  
(LONG DRIVE SHAFT)  
FIGURE 1

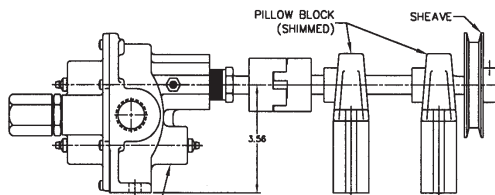

STANDARD N7000L(R)  
SERIES PUMP  
FIGURE 2

#### LIQUIDS AND TEMPERATURE

Service life will be increased substantially if the liquid pumped is clean and has some degree of lubricity. These positive displacement pumps have tight tolerances. Fine abrasives like sand, silt, or powders in suspension will accelerate pump wear and reduce throughput.

Liquids compatible with bronze and stainless steel can be pumped providing proper seal has been specified (see chemical compatibility or check factory). No carbon bearings used. When possible, flush the pump after each usage.

Temperature extremes are detrimental to service life and should be avoided. Basic metals of construction allow a temperature range of -40 to 400°F. Some lip seal elastomers have a limit of 212°F. (see engineering data or check factory). Allowing a liquid to freeze in the pump can cause damage.

#### SUCTION LIFT

Close tolerances and the positive pumping action make the rotary gear pump capable of lifting water on the suction side as high as 20 feet. Though gear pumps are self priming, a foot valve is recommended. If possible, wet the gears with liquid to be pumped for the first dry start. Liquid retained in the system and gear chambers serves to "wet" the pump on subsequent starts.

CAPACITY - WATER 70° F

R.P.M.	FT.HD. P.S.I.	0	46	92	138	184	231	290	346
		0	20	40	60	80	100	125*	150*
400	GPM	4.00	3.45	2.90	2.35	1.50	1.30	1.20	1.00
	HP	0.20	0.23	0.30	0.39	0.55	0.65	0.70	0.90
	MOTOR	1/4	1/4	1/3	1/2	1/2	3/4	3/4	1
600	GPM	6.30	5.78	5.26	4.74	4.22	3.95	3.50	3.10
	HP	0.25	0.30	0.40	0.65	0.75	0.95	1.15	1.40
	MOTOR	1/4	1/3	1/2	3/4	3/4	1	1 1/2	1 1/2
800	GPM	8.58	8.18	7.78	7.38	6.98	6.57	6.40	6.20
	HP	0.30	0.40	0.58	0.85	0.93	1.15	1.40	1.70
	MOTOR	1/3	1/2	3/4	1	1	1 1/2	1 1/2	2
1000	GPM	10.90	10.51	10.12	9.72	9.33	8.93	8.00	7.90
	HP	0.40	0.60	0.70	0.90	1.10	1.38	1.60	1.92
	MOTOR	1/2	3/4	3/4	1	1	1 1/2	2	2
1200	GPM	13.33	12.94	12.55	12.16	11.76	11.37	11.20	11.10
	HP	0.50	0.70	0.85	1.08	1.35	1.65	1.90	2.20
	MOTOR	1/2	3/4	1	1	1 1/2	2	2	3
1600	GPM	18.17	17.79	17.41	17.03	16.65	16.28	16.10	16.00
	HP	0.70	0.91	1.20	1.50	1.80	2.14	2.50	2.90
	MOTOR	3/4	1	1 1/2	1 1/2	2	2	3	3
1725	GPM	19.85	19.48	19.11	18.74	18.37	18.00	17.70	17.40
	HP	0.80	1.10	1.42	1.85	2.18	2.65	3.00	3.60
	MOTOR	1	1	1 1/2	2	2 1/2	3	3	3

H.P. = Actual Horsepower      Motor = Convenient Fractional Size  
 G.P.M. = Gallons per Minute      P.S.I. = Lbs. Per Square Inch Pressure  
 R.P.M. = Revolutions per Min.      Ft. Hd. = Equiv. Press. in Ft of Water

\*For pressures over 100 psi, the above selections are suitable for pumping fluids with lubricity (e.g. oils, polymers). Service life will decrease for fluids without lubricity (e.g. water, solvents).

**MODELS**  
**N7000L**  
**N7000LR**  
**SERIES**

**BRONZE PEDESTAL**  
**ROTARY GEAR PUMPS**

BRONZE BEARINGS



**OBERDORFER PUMPS**

*A Subsidiary of Thomas Industries Inc.*

**EXPLODED VIEW AND PARTS LIST**

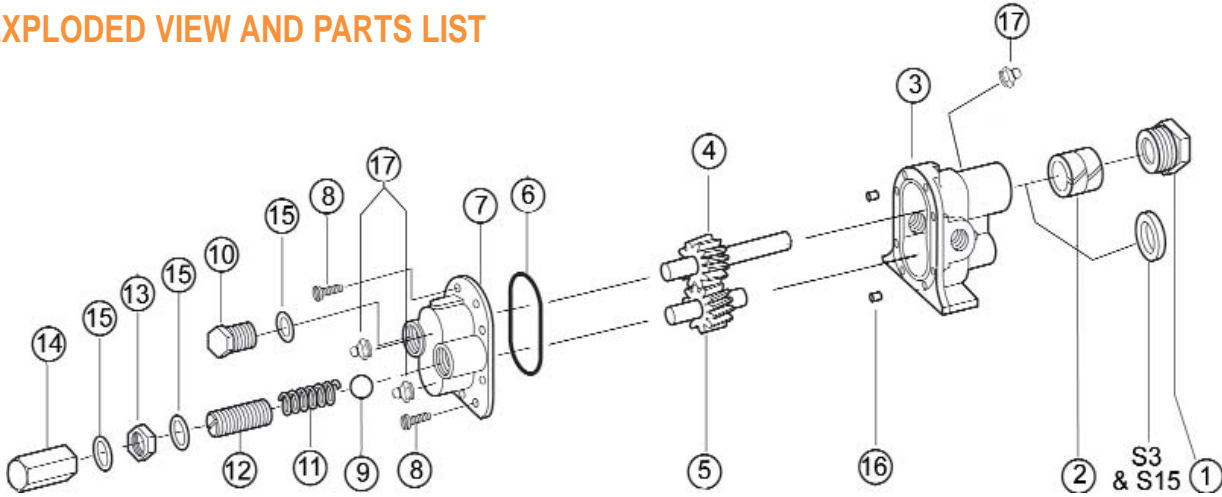

	1	2*	3	4	5	6	7	8	9	10	11	12	13	14	15	16	17	18	19	20
	Packnut	Packing	Body	Drive Gear Ass'y	Idle Gear Ass'y	O-Ring	Cover	Screw	Ball	Plug Nut	Spring	Adj. Screw	Locknut	Bypass Nut	Fiber Washer	Dowel Pin	Grease Fitting	Tag	Stick Screw	Repair Kit
Pump No.	Qty. 1.00	Qty. 2.00	Qty. 1.00	Qty. 1.00	Qty. 1.00	Qty. 1.00	Qty. 1.00	Qty. 8.00	Qty. 1.00	Qty. 1.00	Qty. 1.00	Qty. 1.00	Qty. 1.00	Qty. 1.00	Qty. 3.00	Qty. 2.00	Qty. 3.00	Qty. 1.00	Qty. 2.00	
N7000L	1762	5479	9324PE1N-1	33015	32959	9797-045	9326PN5N-1	5385	N/A	N/A	N/A	N/A	N/A	N/A	N/A	8885	5390	9344	9345	12222
N7000LR	1762	5479	9324PE1N-1	33015	32959	9797-045	9327PN5B-1	5385	6217	5278	5277	5275	1642	5276	6965	8885	Qty. 4.00 5390	9344	9345	12222

Repair Kits contain items 2, 4, 5 and items 18 and 19 not shown above.

*Lipseals		1	2	3	20
Number	Description	Qty. 1.00	Qty. 1.00	Qty. 1.00	Repair Kit
S3	Buna Lipseal	N/A	5463	9324PE2N-1	12223
S15	Viton-Teflon Lipseal	N/A	9997	9324PE2N-1	12224

**DIMENSIONS**

DIMENSIONS N7000LR, N7000LRS3 & N7000LRS15

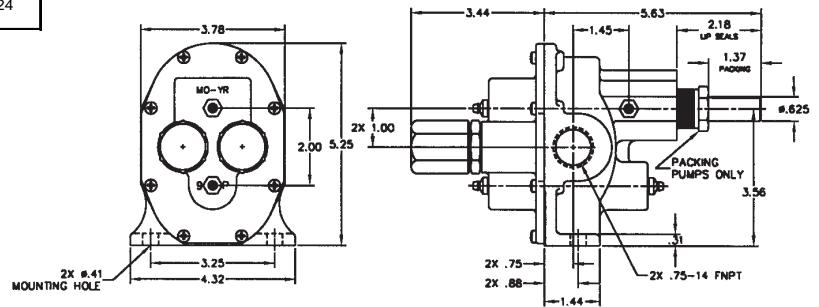

DIMENSIONS N7000L, N7000LS3 & N7000LS15

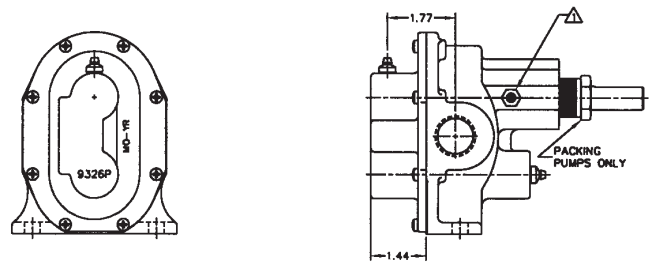

GREASE FITTINGS (ITEM 17) INSTALLED INTO .125-27 NPT CONNECTIONS.

**BY-PASS AND ROTATION**

The pump by-pass is not intended to be a metering or flow control device. Its main purpose is to function as a pressure relief when the desired set point is exceeded, overheating can occur within 5 -10 minutes if the discharge line is completely shut off for extended periods.

Reversing rotation reverses the "IN" and "OUT" ports and the location of the by-pass ports have to be reversed.

The by-pass valve is factory set at 50 p.s.i. To increase the setpoint, turn the by-pass valve adjusting screw in a clockwise direction.

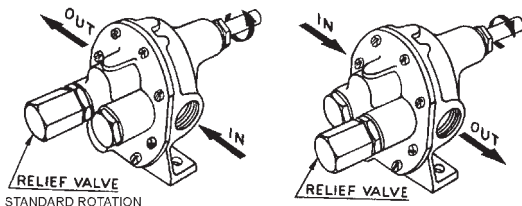

Specifications are subject to change without notice.

\* Viton® or equivalent FKM will be used. Viton® is a registered trademark of DuPont Dow Elastomers. Teflon® or equivalent PTFE will be used. Teflon® is a registered trademark of DuPont.