

CLUTCH-DRIVEN ROTARY GEAR PUMP

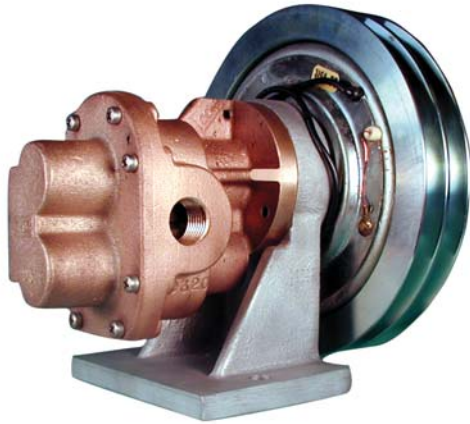

GENERAL DESCRIPTION

Pump housings are made of top quality bronze, shafts are stainless steel 303. Bearings are made of high performance carbon-graphite material selected for wear resistance and long service life. Buna lip seal is suitable for most applications and the external ball bearings support heavy belt drive loads.

Gear pumps are positive displacement pumps. Each shaft revolution displaces a definite amount of liquid. Shaft speed and flow are directly proportional.

LIQUIDS AND TEMPERATURE

These pumps are suitable for all liquids that are compatible with bronze. Most common liquids are water, oil, and mild chemicals in the pH-range of 4 to 11. Viscous liquids require reduced shaft speeds of 1150 RPM or lower. Consult factory.

Liquids containing solids, abrasives, powders or paint pigments are definitely not recommended for gear pumps. If abrasives are unavoidable, use a very low shaft speed. The recommended liquid temperature range is 32° to 140°F for longest pump life. If more extreme temperature conditions exist, our factory should be consulted. Freezing of water-filled pumps can cause damage and must be avoided. Oils at low temperatures are very viscous requiring a lower speed or extra power. Viton lip seals are available.

SUCTION LIFT

As a general rule, the suction lift should be kept at an absolute minimum by placing the pump as close to the liquid as possible. A gear pump in new condition can lift 20 feet of water in the suction line. A foot valve (preferably with a built-in strainer) is recommended at the beginning of the suction line. For a first start-up, the pump should be primed to avoid dry running. Minimum size of the suction pipe is the size of the pump inlet port. For longer suction lines (over 3 feet), or for viscous liquids, the pipe size should be at least one size or two sizes larger than the pump inlet port.

ROTATION AND RELIEF VALVE

The relief valve is not intended to be a metering or flow control device. Its main purpose is to function as a discharge pressure relief when the spring tension is exceeded by the discharge pressure. Overheating can occur within 5-10 minutes if the discharge line is completely shut off for extended periods.

Unless otherwise specified, the clutch driven pump is supplied by the factory for shaft rotation clockwise from shaft end. Reversing the rotation will reverse the "in" and "out" ports and also requires changing the relief valve location. The relief valve is always on the discharge side in this pump series. The factory pressure setting is 50 PSIG. To increase pressure, turn the relief valve adjusting screw in a clockwise direction.

FEATURES

PUMP

- Bronze construction with Stainless Steel shafts
- Helical gears for quiet operation
- Self-lubricating carbon bearings
- O-ring seal for maximum leak protection
- Buna Lip Seal Standard (Viton S15 optional)
- Integral Relief Valve option
- Three Hydraulic Sizes: N994 (10GPM), N970 (19GPM) & N990 (23GPM)

BRACKET

- High grade Aluminum Alloy Mounting pedestal
- External Ball bearing for heavy duty belt drive
 - double sealed/lubed for life

CLUTCH

- Bidirectional
- Electro-Magnetic DC actuated
- 12V standard with fail safe feature
- 24V and 32V available without fail safe
- Leaf spring release
- 2-Groove pulley for 1/2" (13mm) V-belts
- Zinc plated steel construction

USES

MARINE (BOAT ENGINE DRIVEN)

- Deck Washdown
- Diesel Fuel Transfer
- Oil Transfer
- Fire Fighting
- Auxiliary Steering-Barges/Tugs
- Buoy Cleaning

INDUSTRIAL (TRUCK ENGINE DRIVEN)

- Water Transfer-Aircraft
- Road Salt Spray

PERFORMANCE

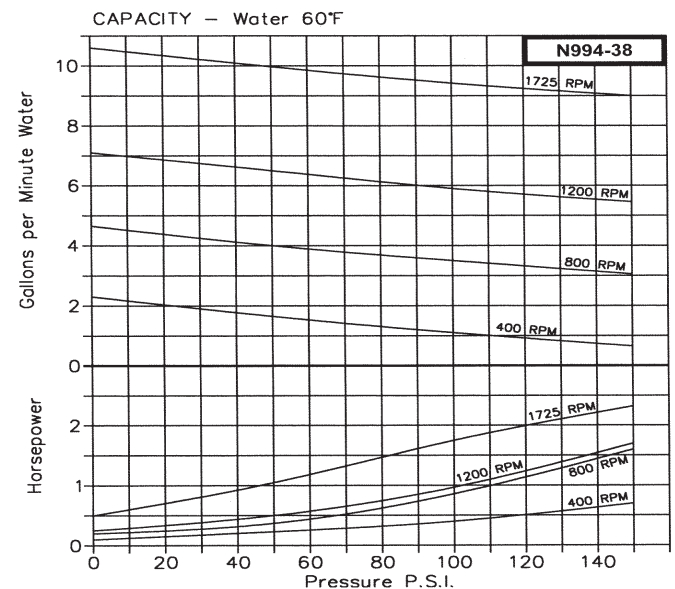

*Viton(R) is a registered trademark of DuPont Dow Elastomers. Viton(R) or equivalent FKM will be used. Teflon(R) is a registered trademark of DuPont. Teflon(R) or equivalent PTFE will be used.

MODELS

N994-38
N970-38
N990-38
SERIES



OBERDORFER PUMPS

A Gardner Denver Product

CLUTCH-DRIVEN ROTARY GEAR PUMP

PERFORMANCE (continued from front)

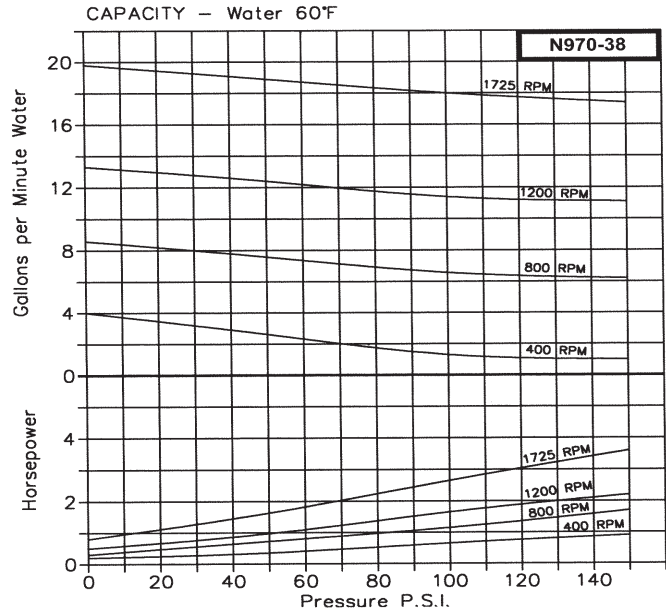
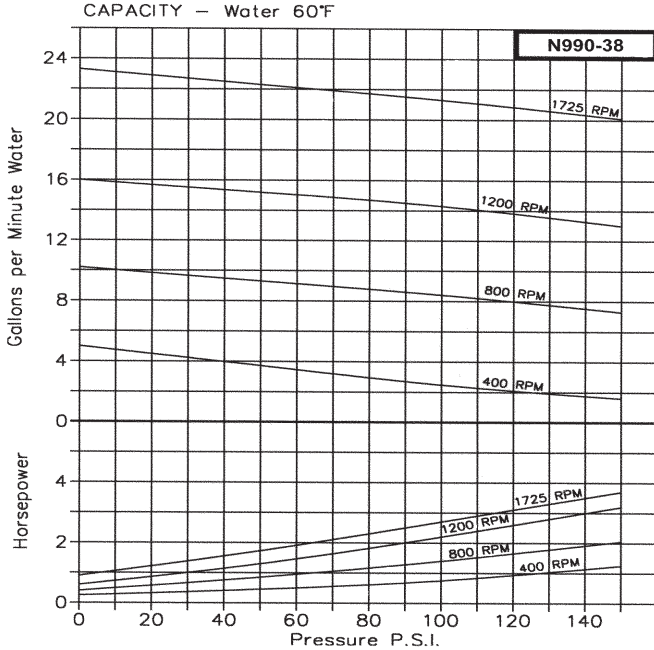

DIMENSIONS

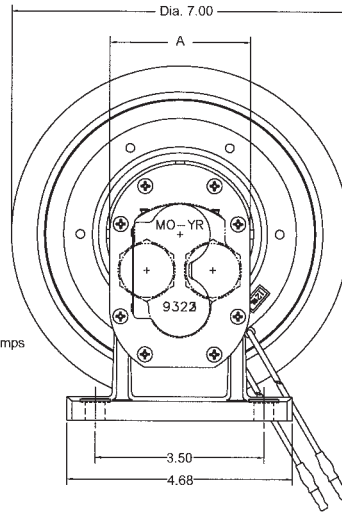
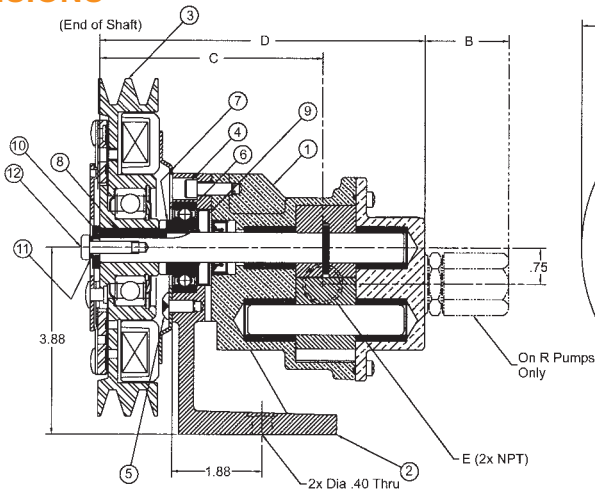

Model	DIM. A	DIM. B	DIM. C	DIM. D	DIM. E (PORT SIZE)
N994-38	2.94	1.75	4.63	6.75	50-14 NPT (.50-14 BSPT, .75-14 NPT & .75-14 BSPT) ALSO AVAILABLE.
N994(R)-38E24	3.00	1.75	4.63	6.75	75-14 NPT (.75-14 BSPT) ALSO AVAILABLE.
N994(R)-38E32	3.75	2.00	4.69	6.81	75-14 NPT (.75-14 BSPT) ALSO AVAILABLE.
N970(R)-38	3.78	2.00	4.69	6.81	1.00-11.5 NPT (1.00-11.5 BSPT) ALSO AVAILABLE.
N990-38	3.75	2.00	4.75	7.06	1.00-11.5 NPT (1.00-11.5 BSPT) ALSO AVAILABLE.
N990(R)-38	3.78	2.00	4.75	7.06	1.00-11.5 NPT (1.00-11.5 BSPT) ALSO AVAILABLE.

Clutch Driven Pump No.	1	2	Clutch Voltage	3a	3b	4	5	6	7	8	9	10	11	12	Gear Pump w/ Bracket ³	Repair Kit ²
	Gear Pump No. ¹	Bracket		Clutch Body	Clutch Coil	Screw	Screw	Ball Bearing	Sleeve	Key	Barrier Seal	Washer	Lock Washer	Screw		
N994(R)-38			12 VDC	9991					2107							
N994(R)-38E24	N994(R)-39	2106	24 VDC	7226	9902	6165	6437	5884	7107	7042	6609	6904	5016	7735	N994(R)-37	12303
N994(R)-38E32			32 VDC	7226	7225				7107							
N970(R)-38			12 VDC	9991					2107							
N970(R)-38E24	N970(R)-39	2106	24 VDC	7226	9902	6165	6437	5884	7107	7042	6609	6904	5016	7735	N970(R)-37	12305
N970(R)-38E32			32 VDC	7226	7225				7107							
N990(R)-38			12 VDC	9991					2107							
N990(R)-38E24	N990(R)-39	2106	24 VDC	7226	9902	6165	6437	5884	7107	7042	6609	6904	5016	7735	N990(R)-37	12304
N990(R)-38E32			32 VDC	7226	7225				7107							
Notes:	1	Standard Buna Lip Seal Configuration with added clutch mounting features														
	2	Repair Kits include Gear Pump repair parts (shafts, gears, bearings, seals) and clutch mount parts 6 and 9														
	3	Includes everything but the clutch and coil														