

BRONZE CLOSE COUPLED ROTARY GEAR PUMPS

MODEL N992(R) Q-J75/J76



MODEL N992(R) C81, C82



PERFORMANCE - WATER 70°

| Model | Voltage | HP | | Pressure (P.S.I.) | | | | | | | | | | | | | | | | |
|-------------|---------|-----|----------------|-------------------|------|------|------|------|------|------|------|------|------|------|------|------|------|------|------|--|
| | | | | 5 | 10 | 15 | 20 | 25 | 30 | 35 | 40 | 45 | 50 | 55 | 60 | 70 | 80 | 90 | 100 | |
| C81 8295 | 12 VDC | 1/4 | Flow (GPM) | 2.8 | 2.7 | 2.7 | 2.6 | 2.5 | 2.4 | 2.3 | 2.2 | 2.1 | 2.1 | 2.0 | | | | | | |
| | | | Speed (RPM) | 1140 | 1120 | 1100 | 1090 | 1070 | 1060 | 1040 | 1020 | 1000 | 990 | 970 | | | | | | |
| | | | Current (Amps) | 4.5 | 5.5 | 6.4 | 7.4 | 8.7 | 9.5 | 10.7 | 12.4 | 13.4 | 14.4 | 15.7 | | | | | | |
| C82 8295 | 24 VDC | 1/4 | Flow (GPM) | 5.9 | 5.8 | 5.8 | 5.7 | 5.6 | | | | | | | | | | | | |
| | | | Speed (RPM) | 2330 | 2310 | 2300 | 2280 | 2270 | | | | | | | | | | | | |
| | | | Current (Amps) | 5.9 | 6.8 | 7.6 | 8.4 | 9.1 | | | | | | | | | | | | |
| C74 2924 | 12 VDC | 1/4 | Flow (GPM) | 5.3 | 5.1 | 5 | 4.9 | 4.7 | | | | | | | | | | | | |
| | | | Speed (RPM) | 2020 | 2020 | 1990 | 1960 | 1920 | | | | | | | | | | | | |
| | | | Current (Amps) | 12.5 | 12.5 | 14.3 | 16.5 | 18.2 | | | | | | | | | | | | |
| F93 3073 | 24 VDC | 1/3 | Flow (GPM) | 4.9 | 4.9 | 4.8 | 4.8 | 4.7 | 4.6 | 4.5 | 4.5 | 4.4 | 4.3 | 4.2 | 4.1 | | | | | |
| | | | Speed (RPM) | 1950 | 1950 | 1950 | 1930 | 1920 | 1910 | 1910 | 1900 | 1890 | 1890 | 1870 | 1850 | | | | | |
| | | | Current (Amps) | 5.1 | 5.5 | 6.1 | 6.9 | 7.7 | 8.6 | 8.9 | 9.2 | 9.8 | 10.1 | 10.5 | 11.5 | 12.8 | | | | |
| J75 8562 | 12 VDC | 1/2 | Flow (GPM) | 4.7 | 4.7 | 4.6 | 4.5 | 4.4 | 4.4 | 4.3 | 4.3 | 4.2 | 4.2 | 4.1 | 4 | 3.8 | 3.7 | | | |
| | | | Speed (RPM) | 1860 | 1850 | 1840 | 1830 | 1830 | 1830 | 1830 | 1820 | 1820 | 1820 | 1820 | 1790 | 1770 | 1750 | | | |
| | | | Current (Amps) | 10.8 | 10.8 | 12.4 | 14.1 | 14.8 | 15.4 | 16.3 | 17.5 | 18.9 | 20.3 | 22.5 | 23.9 | 31.5 | 34.5 | 38.2 | | |
| J76 8563 | 24 VDC | 1/2 | Flow (GPM) | 5.1 | 5.1 | 5 | 6 | 4.9 | 4.8 | 4.8 | 4.7 | 4.6 | 4.6 | 4.5 | 4.4 | 4.3 | 4.1 | 4 | | |
| | | | Speed (RPM) | 2020 | 2020 | 2020 | 2010 | 2000 | 2000 | 1990 | 1990 | 1990 | 1980 | 1980 | 1970 | 1950 | 1940 | 1920 | 1900 | |
| | | | Current (Amps) | 5.8 | 5.8 | 6.3 | 6.9 | 7.5 | 8.2 | 8.8 | 9.2 | 9.9 | 10.5 | 11.3 | 12.2 | 15.9 | 17.3 | 18.7 | | |

Notes: Maximum recommended operating point

FEATURES

- Compact design eases installation and use in limited space areas.
- Construction is bronze and stainless steel wetted components.
- Close tolerance design allows for consistent performance.
- Self-Lubricating Bearings
- Complete Units Available
- Slotted Motor Base
- Permanent Magnet Rigid Base Motors

GENERAL DESCRIPTION

Pump housings and gears are made of top quality bronze, shafts are 303 stainless steel. Bearings are designed of high performance carbon-graphite material selected for wear resistance and long service life.

Gear pumps are positive displacement pumps. Each shaft revolution displaces a definite amount of liquid relatively unaffected by the back pressure in the discharge line. Shaft speed and flow are directly proportional.

LIQUIDS AND TEMPERATURE

Compact DC portable units convenient for on site servicing of vehicles, machinery and field equipment. For pumping oil direct from crankcase or oil reservoir, drums, containers, transfer diesel fuel to vehicles, pumping other liquids and chemicals compatible with materials of construction. Pumping viscous oils, SAE 30 or greater, can overload motor. Intermittent use is recommended when pumping viscous oils, especially in cold weather.

Service life will be increased substantially if liquid pumped is clean and has lubricity value. These pumps have extremely close tolerances. Fine abrasives like sand, silt or powders in suspension will destroy pumping ability.

Liquids compatible with bronze, stainless steel and the Buna lip seal can be pumped. For solvents a Viton lip seal is available. For a Viton(R)* Seal, add S5 to the pump model number. See chemical compatibility table.

Temperature extremes are detrimental to service life and should be avoided. Basic metals of construction allow temperature range of -40° to 400°F. Standard Buna lip seal has a temperature limit of 250°F, while the Viton lip seal will handle up to 300°F. Freezing liquid in the pump can deform or damage the pump.

SUCTION LIFT

As a general rule, the suction lift should be kept at an absolute minimum by placing the pump as close to the liquid source as possible. A gear pump in new condition can lift 20 feet of water in the suction line. A foot valve (preferably with built-in strainer) is recommended at the beginning of the suction line. For a first start-up, the pump should be primed to avoid dry running. Minimum size of the suction pipe is the size of the pump inlet port. For longer suction lines (over 3 feet) or for viscous liquids, the pipe should be at least one size or two sizes larger than the pump inlet port.

ROTATION AND RELIEF VALVE

If the discharge line contains any throttling devices such as a shut-off valve, a spray nozzle or other restrictive device, it is necessary to have a relief valve in the system which returns the liquid to the suction side or to the tank. The relief valve is also available as part of the pump itself (R-model pumps). However, built-in relief valves are only good for intermittent service. If used continuously, the pump will overheat. A built-in relief valve is strictly a safety device against overpressure. It will not work successfully as a pressure or flow control device. For this purpose a separate relief valve in the pressure line must be used.

Unless otherwise specified, the pump motor unit is supplied by the factory for shaft rotation counterclockwise from shaft end. Reversing motor will reverse "in and "out" ports and also requires changing relief valve location. The relief valve is always on the inlet side of this pump series. The factory pressure setting is 50 PSIG. To increase pressure, turn the relief valve adjusting screw in a clockwise direction.

BRONZE CLOSE COUPLED ROTARY GEAR PUMPS

EXPLODED VIEW AND PARTS LIST

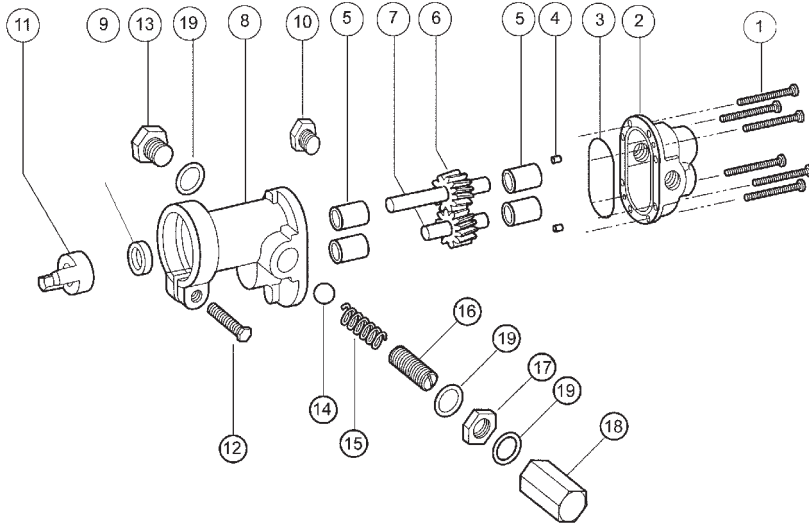

DIMENSIONS & ROTATION

N992(R) C81, C82

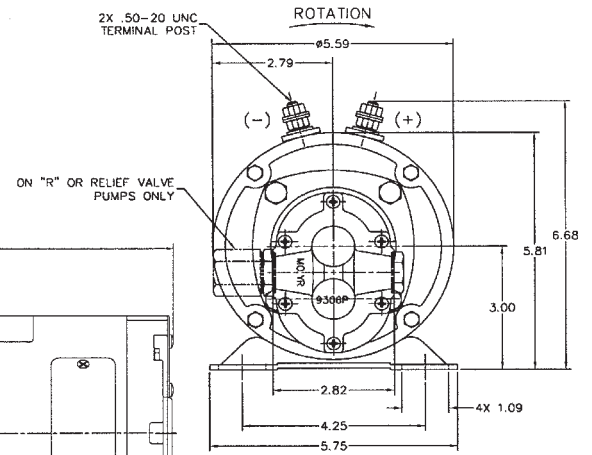
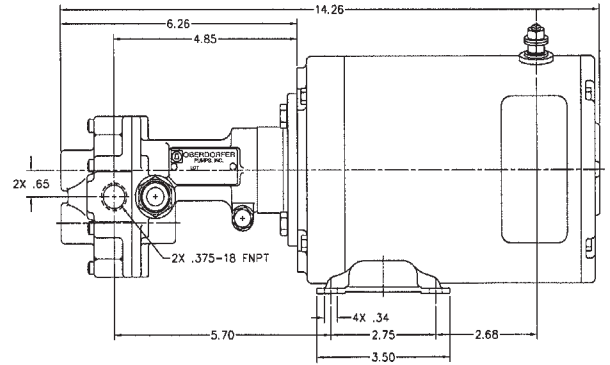

N992(R) Q-J75/J76

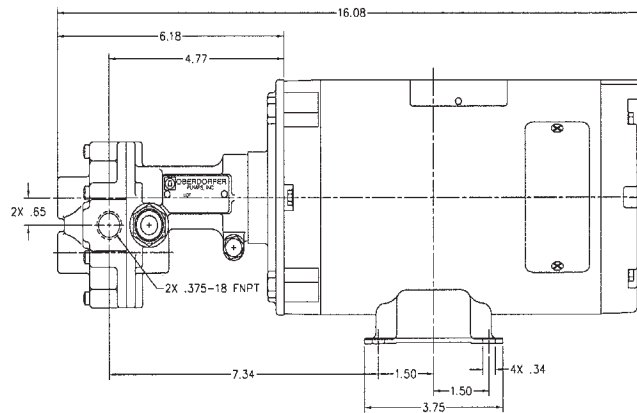
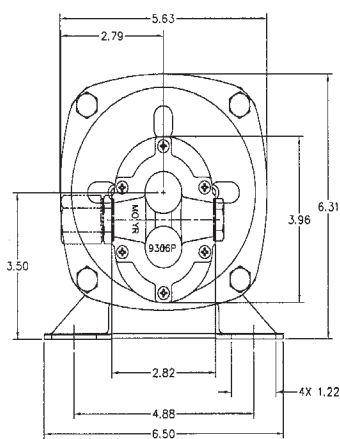

| Pump No. | 1 | 2 | 3 ¹ | 4 | 5 ¹ | 6 ¹ | 7 ¹ | 8 | 9 ^{1,2} | 10 | 11 | 12 | 13 | 14 | 15 | 16 | 17 | 18 | 19 |
|----------|---------|----------|----------------|-----------|----------------|------------------|-----------------|----------|------------------|----------|----------|---------|----------|---------|---------|------------|---------|------------|--------------|
| | Screw | Body | O-Ring | Dowel Pin | Bearing | Drive Gear Assy. | Idle Gear Assy. | Cover | Lip Seal | Cap Plug | Coupling | Screw | Plug Nut | Ball | Spring | Adj. Screw | Locknut | Bypass Nut | Fiber Washer |
| N992 | 6 Req'd | 1 Req'd | 1 Req'd | 2 Req'd | 1 Req'd | 1 Req'd | 1 Req'd | 1 Req'd | 1 Req'd | 1 Req'd | 1 Req'd | 1 Req'd | 1 Req'd | 1 Req'd | 1 Req'd | 1 Req'd | 1 Req'd | 1 Req'd | 3 Req'd |
| N992R | 5013 | 9306NC5N | 9797-038 | 8885 | 5024 | 32994 | 32993 | 9308NN2N | 5007 | 9346 | 5604 | 5595 | --- | --- | --- | --- | --- | --- | --- |
| N992R | 5013 | 9306NC5N | 9797-038 | 8885 | 5024 | 32994 | 32993 | 9308NN3B | 5007 | 9346 | 5604 | 5595 | 1838 | 5238 | 1840 | 5237 | 5240 | 5239 | 6533 |

¹ Repair Kits contain items 3, 5, 6, 7 & 9. Repair Kit for N992(R) is #10631.

² Seal #5007 is standard Buna N, #7580 is Viton(R)*-Teflon(R)*.

| Product Number | | | | 20 | 21 | 22 | 23 | 26 | 27 |
|----------------|---|---|-----|---------|---------------|------------------|---------|---------|-------------|
| | | | | Spider | Coupling Half | Bracket/ Adapter | Screw | Motor | Adapter Kit |
| N992(R) | Q | - | J76 | 1 Req'd | 1 Req'd | 1 Req'd | 4 Req'd | 1 Req'd | 1 Req'd |
| N992(R) | Q | - | J75 | 7839 | 7643 | 8335 | 5411 | 8563 | 11331 |
| N992(R) | Q | - | F93 | 7839 | 7643 | 8335 | 5411 | 3073 | 11331 |
| N992(R) | Q | - | C74 | 7839 | 7643 | 8335 | 5411 | 2924 | 11331 |
| N992(R) | - | - | C81 | 7839 | 7643 | 7602 | 5916 | 8295 | 12144 |
| N992(R) | - | - | C82 | 7839 | 7643 | 7602 | 5916 | 8295 | 12144 |

RECOMMENDED WIRE SIZE AND LENGTH AWG WIRE SIZE AND MAXIMUM LENGTH IN FEET

| | NO.14 | NO.12 | NO.10 | NO.8 |
|------------|--------|--------|--------|---------|
| 12 VOLT DC | 11 FT. | 18 FT. | 28 FT. | 45 FT. |
| 24 VOLT DC | 20 FT. | 34 FT. | 55 FT. | 87 FT. |
| 32 VOLT DC | 35 FT. | 56 FT. | 91 FT. | 144 FT. |